

# WEIDER<sup>®</sup> 2980 X

Model No. WESY19318.0

Serial No. \_\_\_\_\_

Write the serial number in the space above for reference.

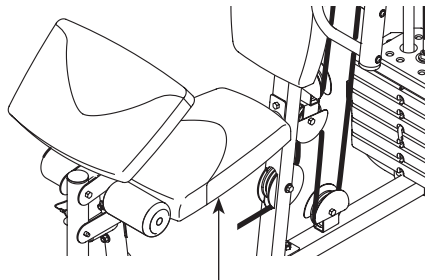

Serial Number Decal (under seat)

## USER'S MANUAL

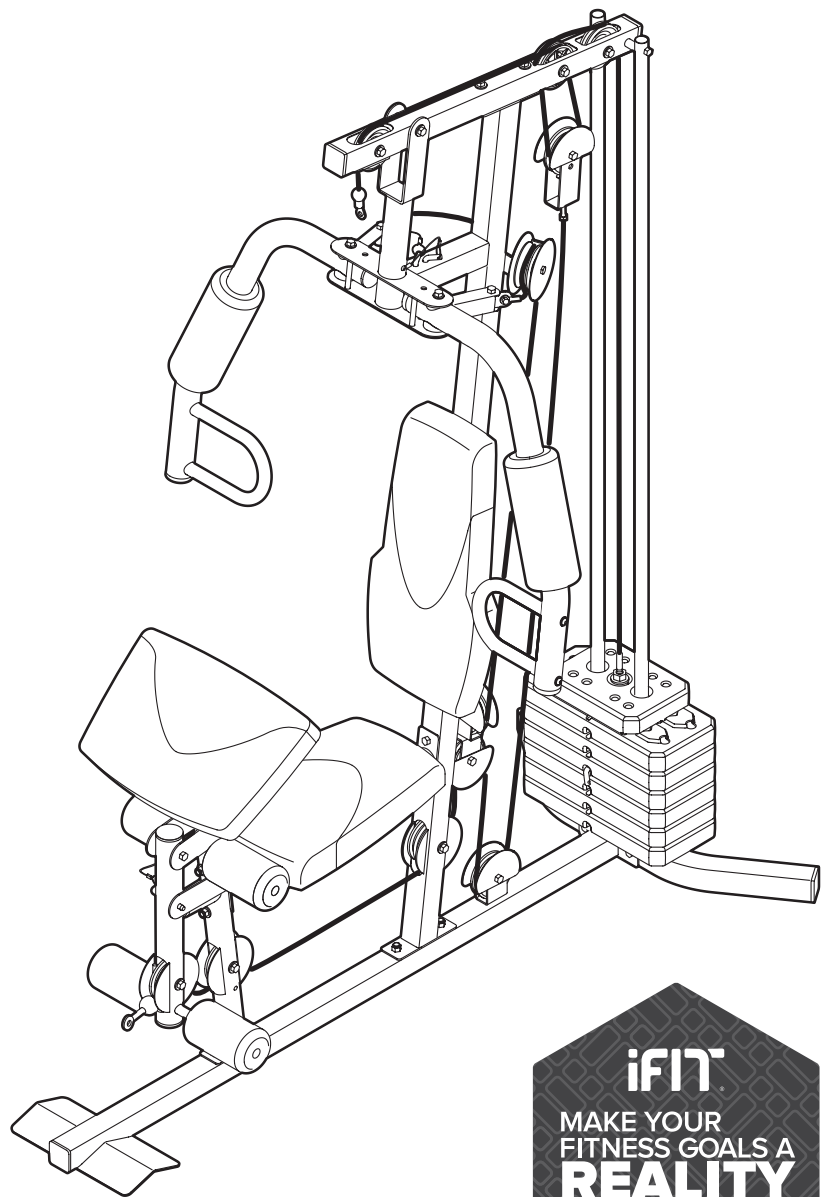

### **! CAUTION**

Read all precautions and instructions in this manual before using this equipment. Keep this manual for future reference.



# TABLE OF CONTENTS



|                                 |    |
|---------------------------------|----|
| WARNING DECAL PLACEMENT .....   | 2  |
| IMPORTANT PRECAUTIONS .....     | 3  |
| BEFORE YOU BEGIN .....          | 5  |
| PART IDENTIFICATION CHART ..... | 6  |
| ASSEMBLY .....                  | 7  |
| ADJUSTMENT .....                | 19 |
| WEIGHT RESISTANCE CHART .....   | 21 |
| CABLE DIAGRAM .....             | 22 |
| MAINTENANCE .....               | 23 |
| EXERCISE GUIDELINES .....       | 24 |
| PART LIST .....                 | 25 |
| EXPLODED DRAWING .....          | 26 |

## WARNING DECAL PLACEMENT

This drawing shows the location(s) of the warning decal(s). **If a decal is missing or illegible, see the front cover of this manual and request a free replacement decal. Apply the decal in the location shown.** Note: The decal(s) may not be shown at actual size.

**⚠ WARNING**

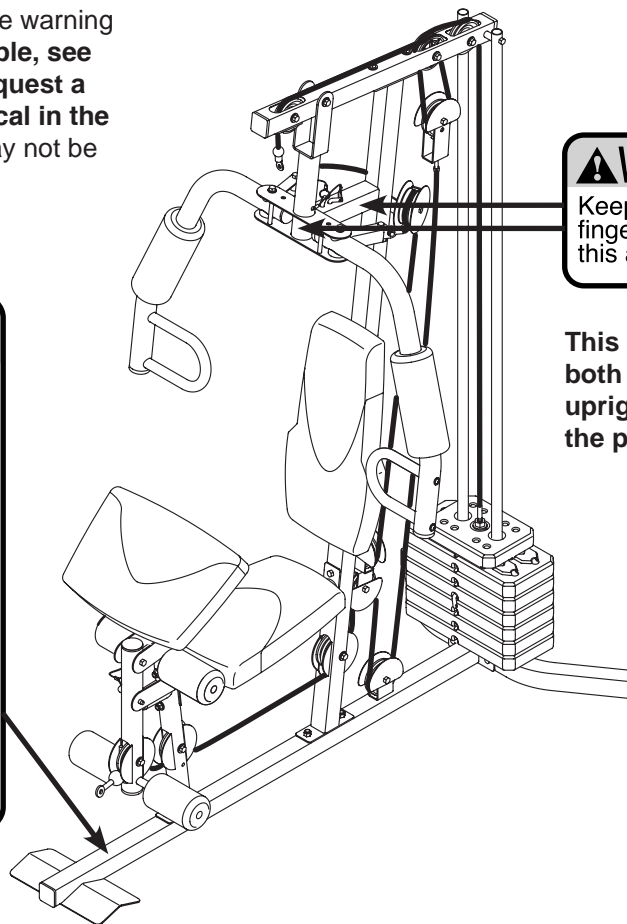
- Misuse of this machine may result in serious injury.
- Maximum user weight: 300 lbs.
- Read the user's manual prior to use and follow all warnings and instructions.
- Do not allow children on or around machine.
- Keep body, clothing, and hair free and clear of all moving parts.
- Replace label if damaged or illegible.



**⚠ WARNING**  
Keep hands and fingers clear of this area.

This decal is on both sides of the upright and on the pivot frame.

# IMPORTANT PRECAUTIONS

**⚠️ WARNING:** To reduce the risk of serious injury, read all important precautions and instructions in this manual and all warnings on the weight system before using the weight system. ICON assumes no responsibility for personal injury or property damage sustained by or through the use of this product.

1. It is the responsibility of the owner to ensure that all users of the weight system are adequately informed of all precautions.
2. Before beginning any exercise program, consult your physician. This is especially important for persons over age 35 or persons with pre-existing health problems.
3. The weight system is not intended for use by persons with reduced physical, sensory, or mental capabilities or lack of experience and knowledge, unless they are given supervision or instruction about use of the weight system by someone responsible for their safety.
4. Use the weight system only as described in this manual.
5. The weight system is intended for home use only. Do not use the weight system in a commercial, rental, or institutional setting.
6. Keep the weight system indoors, away from moisture and dust. Do not put the weight system in a garage or covered patio, or near water.
7. Use the weight system only on a level surface. Cover the floor beneath the weight system to protect the floor.
8. Inspect and properly tighten all parts each time the weight system is used. Replace any worn parts immediately.
9. Keep children under age 13 and pets away from the weight system at all times.
10. The weight system should not be used by persons weighing more than 300 lbs. (136 kg).
11. Wear appropriate exercise clothes while exercising; do not wear loose clothes that could become caught on the weight system. Always wear athletic shoes for foot protection while exercising.
12. Keep hands and feet away from moving parts.
13. Always secure the weight stack with the lock pin and lock after exercising to prevent unauthorized use of the weight system (see LOCKING THE WEIGHT STACK on page 21).
14. Make sure that the cables remain on the pulleys at all times. If the cables bind while you are exercising, stop immediately and make sure that the cables are on the pulleys.
15. Always stand on the foot plate while performing an exercise that could cause the weight system to tip.
16. Never release the arms, leg lever, lat bar, or handle strap while weights are raised; the weights will fall with great force.
17. Always disconnect the lat bar from the weight system before performing an exercise that does not require the lat bar.
18. Over exercising may result in serious injury or death. If you feel faint, if you become short of breath, or if you experience pain while exercising, stop immediately and cool down.

# BEFORE YOU BEGIN

Thank you for selecting the versatile WEIDER® 2980 X weight system. The 2980 X weight system is designed to develop the major muscle groups of the body. Whether your goal is to have a shapely figure, dramatic muscle size and strength, or a healthier cardiovascular system, the weight system will help you to achieve the specific results you want.

**For your benefit, read this manual carefully before using the weight system.** If you have questions after

reading this manual, please see the front cover of this manual. To help us assist you, note the product model number and serial number before contacting us. The model number and the location of the serial number decal are shown on the front cover of this manual.

Before reading further, please review the drawing below and familiarize yourself with the labeled parts.

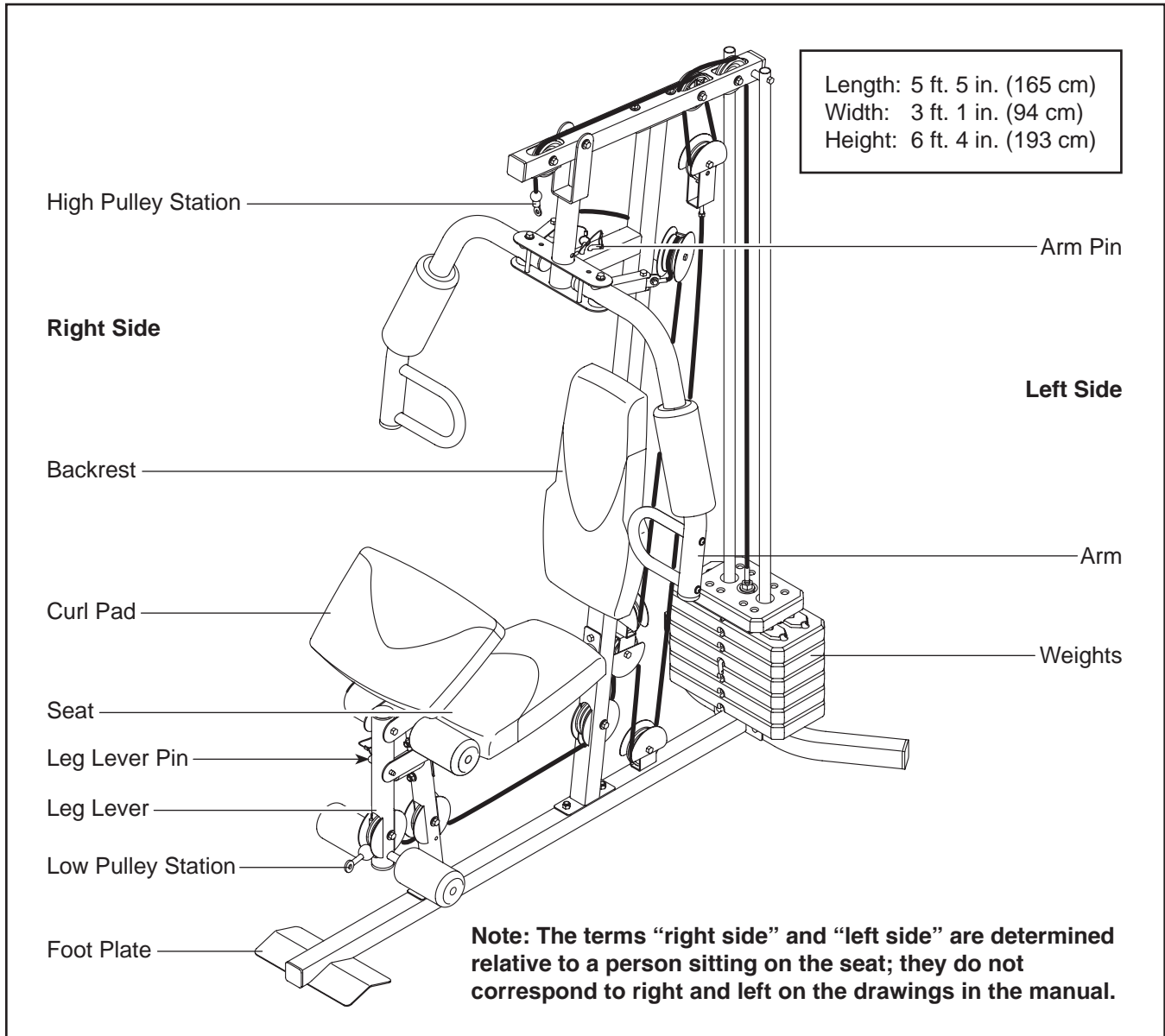

# PART IDENTIFICATION CHART

Use the drawings below to identify the small parts needed for assembly. The number in parentheses below each drawing is the key number of the part, from the PART LIST near the end of this manual. **Note: If a part is not in the hardware kit, check to see if it has been preassembled. Extra parts may be included.**

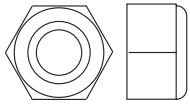

M8 Locknut (58)

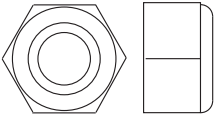

M10 Locknut (56)

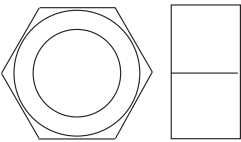

M12 Nut (82)

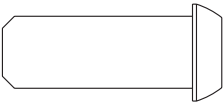

M10 x 25mm Screw (77)

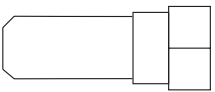

M8 x 22mm Shoulder Bolt (65)

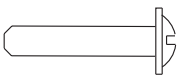

M4 x 20mm Self-tapping Screw (69)

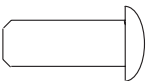

M6 x 16mm Screw (62)

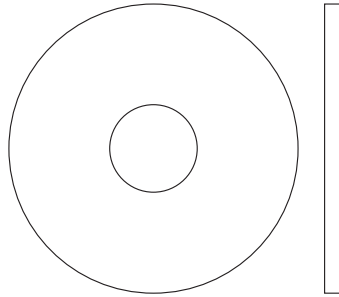

Large Washer (78)

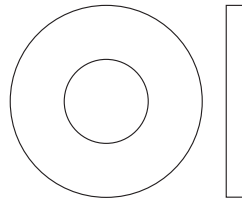

M10 Washer (57)

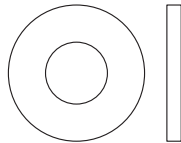

M8 Washer (59)

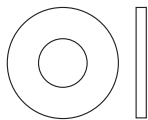

M6 Washer (80)



M4 Washer (33)

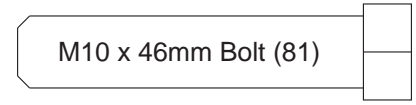

M10 x 46mm Bolt (81)



M10 x 51mm Bolt (66)



M6 x 63mm Screw (70)

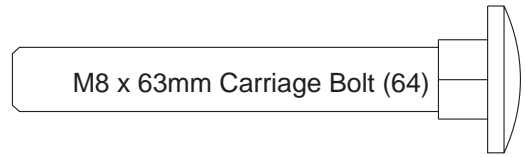

M8 x 63mm Carriage Bolt (64)

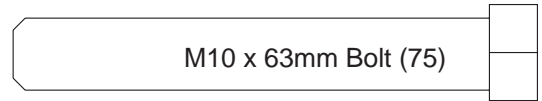

M10 x 63mm Bolt (75)

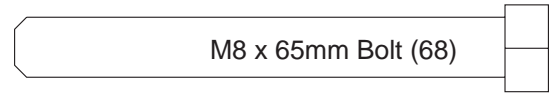

M8 x 65mm Bolt (68)

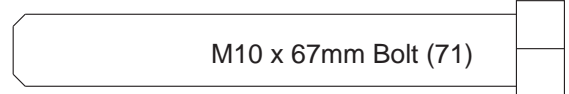

M10 x 67mm Bolt (71)

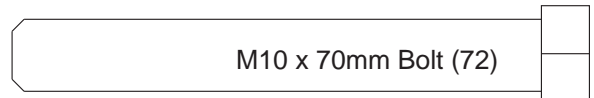

M10 x 70mm Bolt (72)

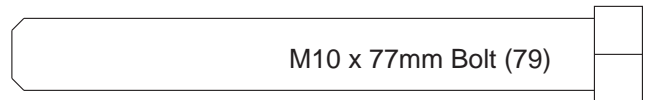

M10 x 77mm Bolt (79)

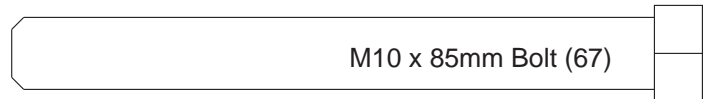

M10 x 85mm Bolt (67)

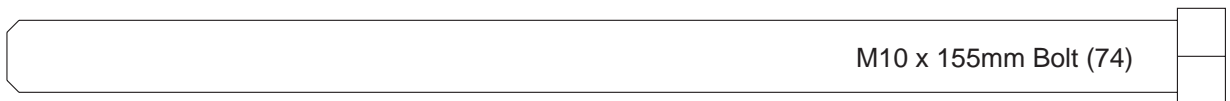



M10 x 155mm Bolt (74)

# ASSEMBLY

- To hire an authorized service technician to assemble this product, call 1-800-445-2480.
- Assembly requires two persons.
- Because of its weight and size, assemble the weight system in the location where it will be used. Make sure that there is enough clearance to walk around the weight system.
- **Place all parts in a cleared area and remove the packing materials.** Do not dispose of the packing materials until you finish all assembly steps.
- Left parts are marked “L” or “Left” and right parts are marked “R” or “Right.”

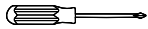
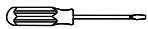
- To identify small parts, see page 6.
- In addition to the included tool(s), assembly requires the following tool(s):

- one Phillips screwdriver 
- one standard screwdriver 
- two adjustable wrenches 
- one rubber mallet 

**Assembly may be easier if you have your own set of wrenches.** To avoid damaging parts, do not use power tools.

## The Four Stages of the Assembly Process

**Frame Assembly**—You will begin by assembling the base and the uprights that form the skeleton of the weight system.

**Arm Assembly**—During this stage you will assemble the arms and the leg lever.

**Cable Assembly**—During this stage you will attach the cables and pulleys that connect the arms to the weights.

**Seat Assembly**—During the final stage you will assemble the seat and the backrest.

### 1. Go to meiderfitness on your computer and register your product.

- documents your ownership
- activates your warranty
- ensures priority customer support if assistance is ever needed

Note: If you do not have internet access, call Customer Care (see the front cover of this manual) and register your product.

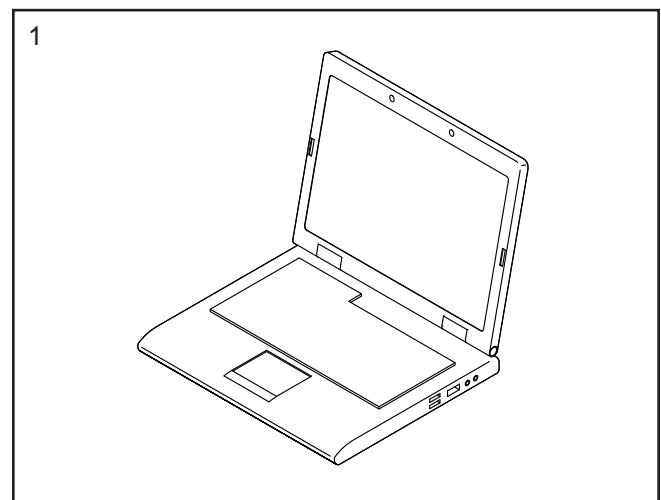

## Frame Assembly

2. To make assembly easier, read the information on page 7. Before you begin, make sure that you have:
- removed the packaging materials from all of the parts
  - placed all of the parts near you in a clear area
  - located the included grease packet

Insert four M8 x 63mm Carriage Bolts (64) upward into the Base (1). **Tip: It may be helpful to place a piece of tape over the bolt heads to hold them in place.**

3. Orient the two Weight Guides (21) so that the indicated holes (A) are closer to the lower ends.

Attach the Weight Guides (21) and the Stabilizer (2) to the Base (1) with two M10 x 67mm Bolts (71), two M10 Washers (57), and two M10 Locknuts (56). **Fully tighten the Locknuts.**

Then, attach the Upright (3) to the Base (1) with the two indicated M8 x 63mm Carriage Bolts (64) and two M8 Locknuts (58). **Do not tighten the Locknuts yet.**

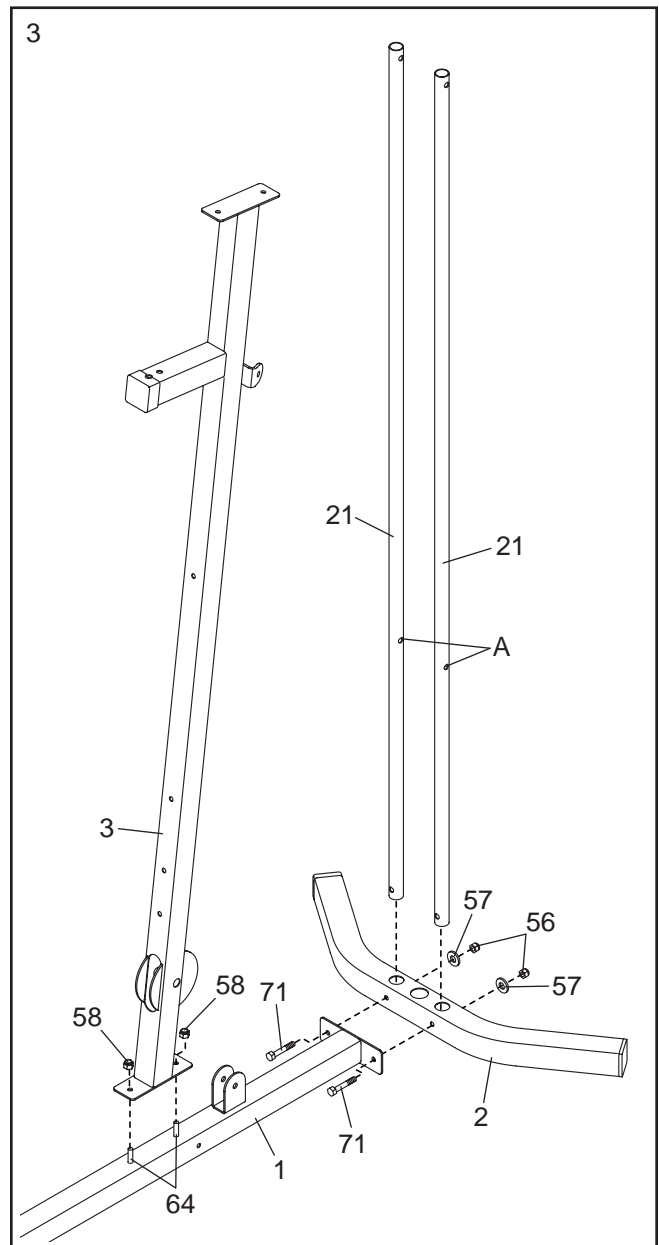
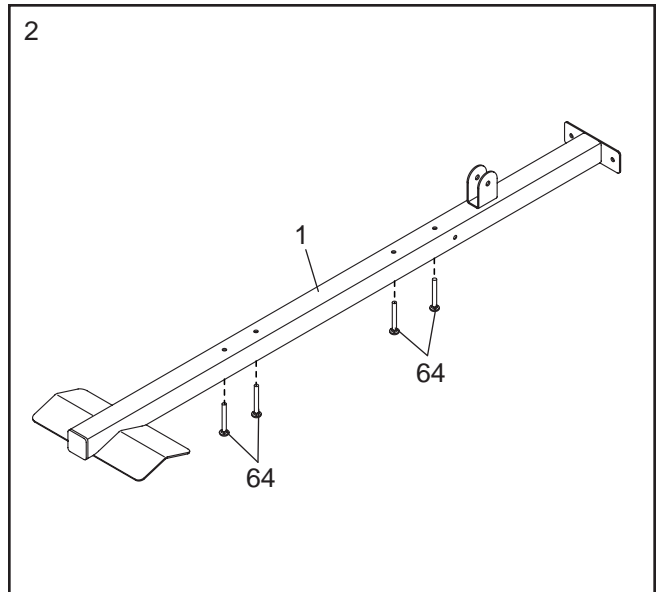

4. Attach the Front Leg (7) to the Base (1) with the two M8 x 63mm Carriage Bolts (64) and two M8 Locknuts (58). **Do not tighten the Locknuts yet.**

Next, hold the Leg Bumper (60) against the Front Leg (7), and **turn the Leg Bumper so that it is angled upward (B).**

Attach the Leg Bumper (60) with an M4 x 20mm Self-tapping Screw (69) and an M4 Washer (33).

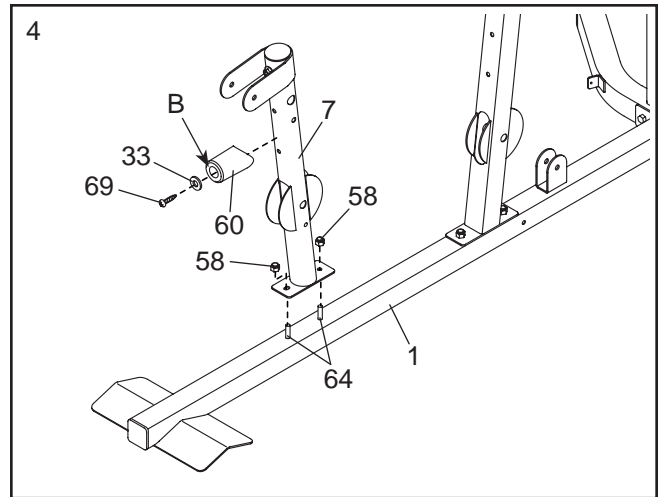

5. Attach the Seat Frame (6) to the Upright (3) with two M8 x 65mm Bolts (68), two M8 Washers (59), and two M8 Locknuts (58). **Do not tighten the Locknuts yet.**

Attach the Seat Frame (6) to the Front Leg (7) in the same way.

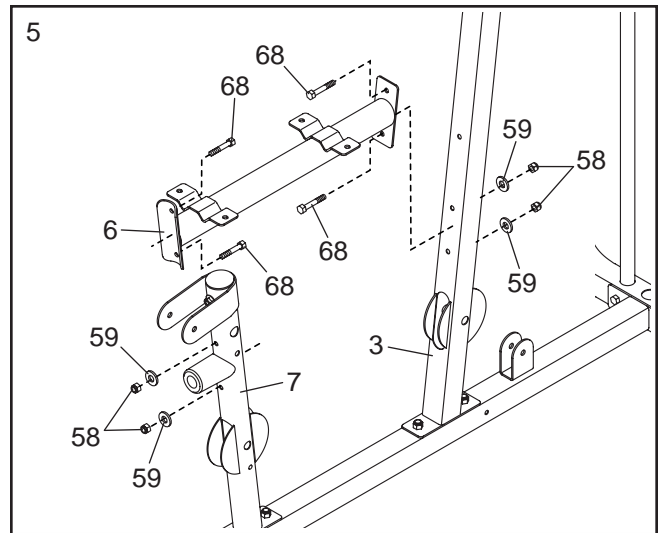

6. Slide the two Weight Bumpers (27) onto the Weight Guides (21).

Next, orient the six Weights (22) so that the pin holes (C) are on the bottom, and slide them onto the Weight Guides (21).

Next, insert the Weight Selector Cap (23) into the Weight Selector (24), and insert the Weight Selector into the six Weights (22). **Make sure that the pin on the Weight Selector is oriented as shown.**

Then, using a plastic bag to keep your fingers clean, apply some of the included grease to the indicated holes in the Top Weight (25), and slide the Top Weight onto the Weight Guides (21).

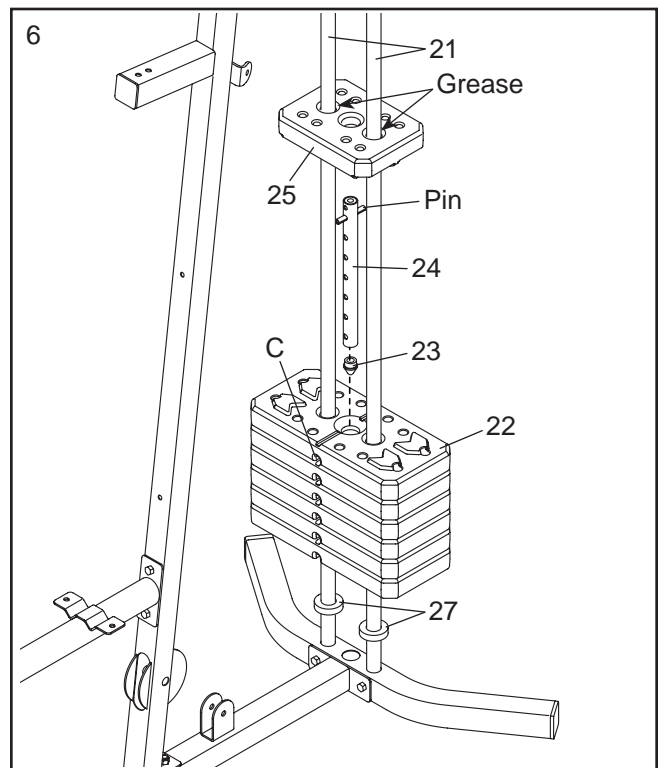



7. Orient the Top Frame (4) so that the welded support (D) is on the bottom.

Attach the Top Frame (4) to the Upright (3) with two M8 x 65mm Bolts (68), two M8 Washers (59), and two M8 Locknuts (58). **Do not tighten the Locknuts yet.**

Then, attach the Top Frame (4) between the Weight Guides (21) with an M10 x 155mm Bolt (74), two M10 Washers (57), two 19mm Spacers (76), and an M10 Locknut (56).

**See steps 3, 4, 5, and 7.** Tighten the M8 Locknuts (58).

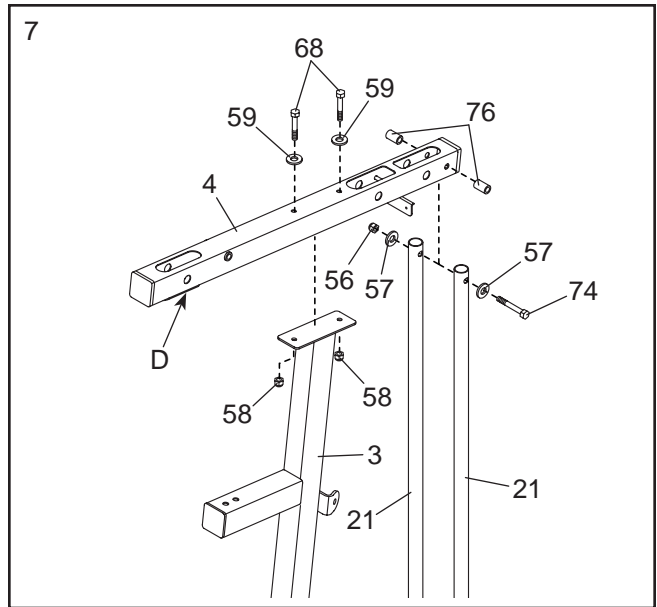

## Arm Assembly

8. Grease an M10 x 77mm Bolt (79).

Orient the Leg Lever (8) so that the welded support (E) is on the side shown. Attach the Leg Lever to the Front Leg (7) with the M10 x 77mm Bolt (79) and an M10 Locknut (56). **Do not overtighten the Locknut; the Leg Lever must pivot easily.**

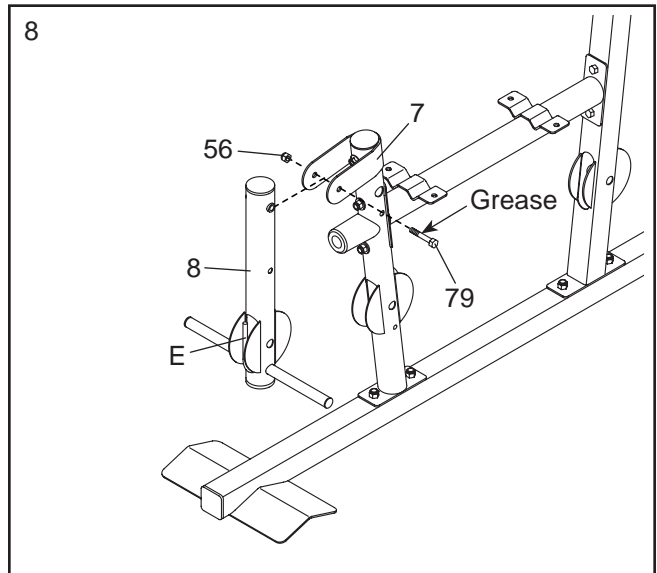

9. Grease an M10 x 77mm Bolt (79).

Attach the Pivot Frame (5) to the Top Frame (4) with the M10 x 77mm Bolt (79) and an M10 Locknut (56). **Do not overtighten the Locknut; the Pivot Frame must pivot easily.**

Next, attach the two Arm Pins (40) to the Pivot Frame (5) with two M4 x 20mm Self-tapping Screws (69).

Insert the Arm Pins (40) into the two holes (F) in the Upright (3).

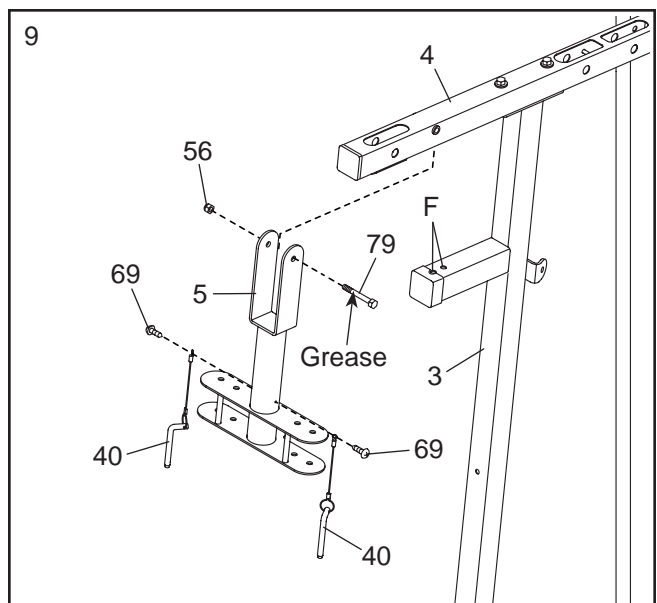

10. Grease an M10 x 51mm Bolt (66).

Attach a Cable Pivot (39) to the Left Arm (10) with the M10 x 51mm Bolt (66) and an M10 Locknut (56). **Do not overtighten the Locknut; the Cable Pivot must pivot easily.**

Next, wet the inside of a Large Foam Pad (42) with soapy water. Slide the Large Foam Pad onto the Left Arm (10).

Then, attach a Handle (11) to the Left Arm (10) with two M10 x 25mm Screws (77) and two M10 Washers (57).

**Assemble the Right Arm (9) in the same way.**

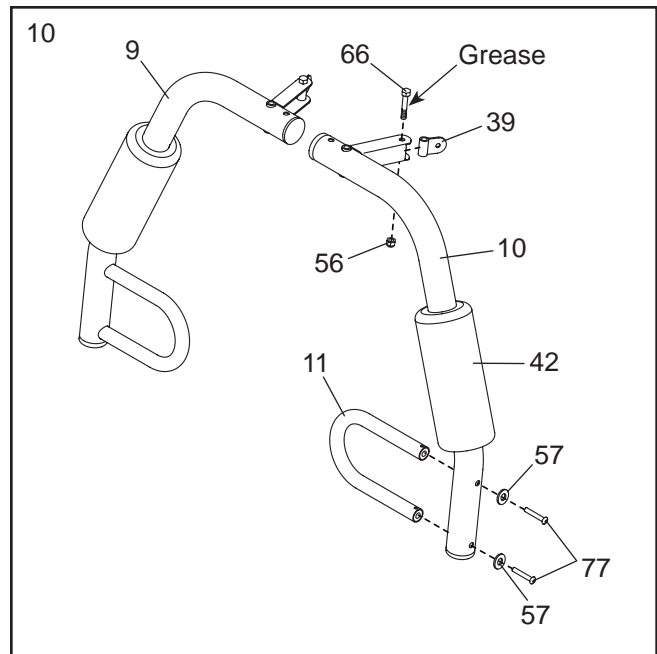

11. Grease an M10 x 85mm Bolt (67) and two Arm Bushings (44).

Attach the Right Arm (9) to the Pivot Frame (5) with the M10 x 85mm Bolt (67), two M10 Washers (57), the two Arm Bushings (44), and an M10 Locknut (56). **Do not overtighten the Locknut; the Right Arm must pivot easily.**

**Attach the Left Arm (10) to the Pivot Frame (5) in the same way.**

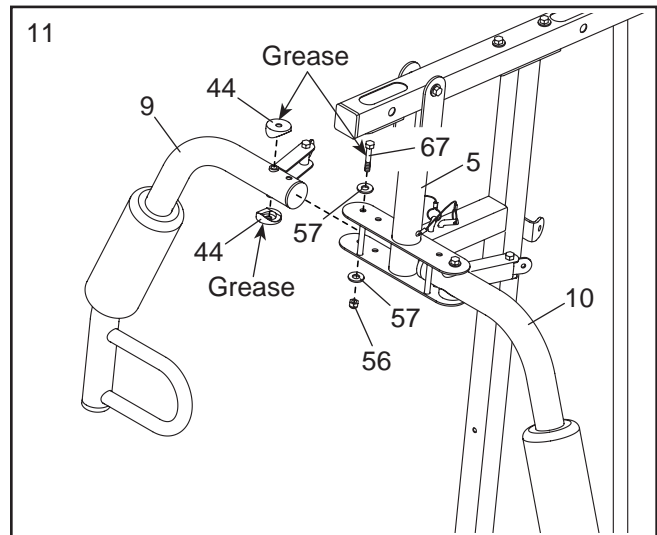

## Cable Assembly

12. **IMPORTANT:** See the **CABLE DIAGRAM** on page 22. Cut along the dotted line, and lay the **CABLE DIAGRAM** beside this manual for reference while you assemble the cables and the pulleys.

**Identify the Arm Cable (54).**

Grease an M8 x 22mm Shoulder Bolt (65).

Attach the Arm Cable (54) to the indicated Cable Pivot (39) with the M8 x 22mm Shoulder Bolt (65) and an M8 Locknut (58). **Make sure that the cable end can pivot easily on the Shoulder Bolt.**

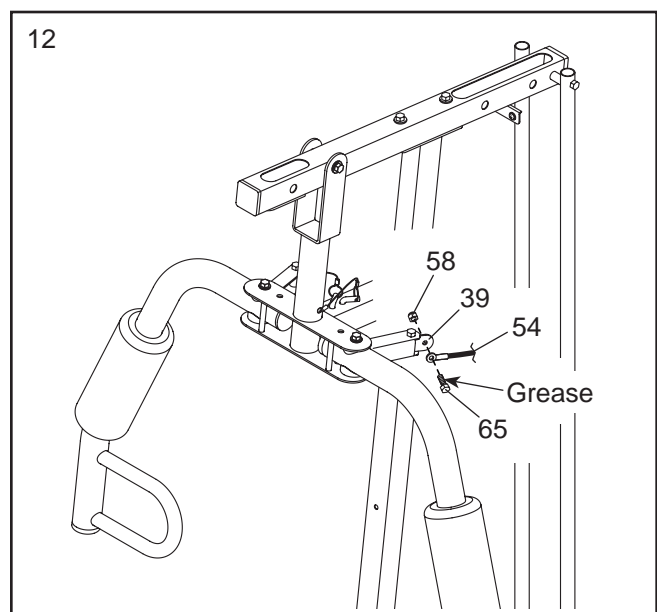

13. **IMPORTANT:** Identify the two V-pulleys (46), the nine Pulleys (48), and the two Thin Pulleys (47).

**Tip:** It may be helpful to refer to the **EXPLODED DRAWING** near the end of this manual to identify the locations of the pulleys.

Route the Arm Cable (54) over a V-pulley (46).

Attach the V-pulley (46), a Large Cable Trap (50), two Full Guards (41), and an M10 Washer (57) to the Upright (3) with an M10 x 63mm Bolt (75) and an M10 Locknut (56).

**Make sure that the Large Cable Trap (50) is oriented to hold the Arm Cable (54) in the groove of the V-pulley (46).**

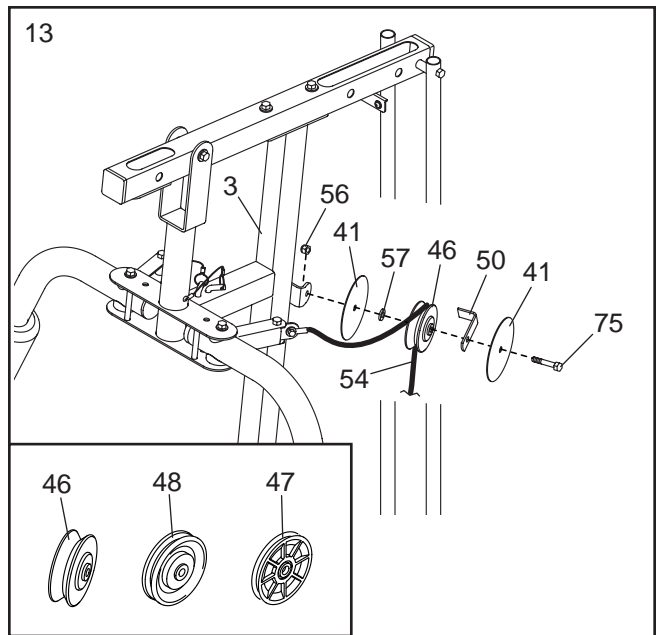

14. Route the Arm Cable (54) under a Pulley (48).

Attach the Pulley (48) and two Half Guards (43) to the Double U-bracket (63) with an M10 x 46mm Bolt (81) and an M10 Locknut (56). **Make sure that the Half Guards are on the outside of the U-bracket as shown.**

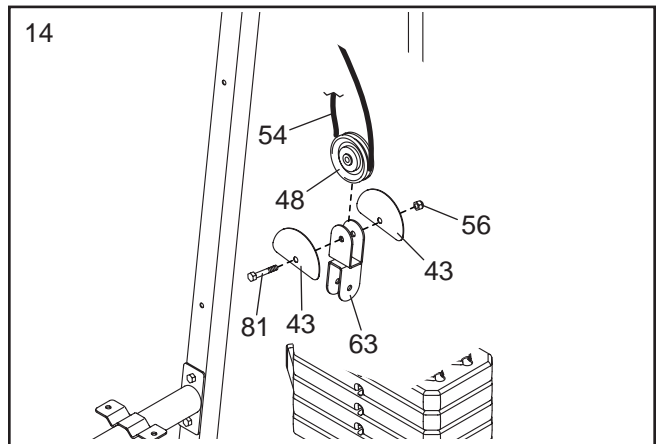

15. Route the Arm Cable (54) over a V-pulley (46).

Attach the V-pulley (46), a Large Cable Trap (50), two Full Guards (41), and an M10 Washer (57) to the Upright (3) with an M10 x 63mm Bolt (75) and an M10 Locknut (56).

**Make sure that the Large Cable Trap (50) is oriented to hold the Arm Cable (54) in the groove of the V-pulley (46).**

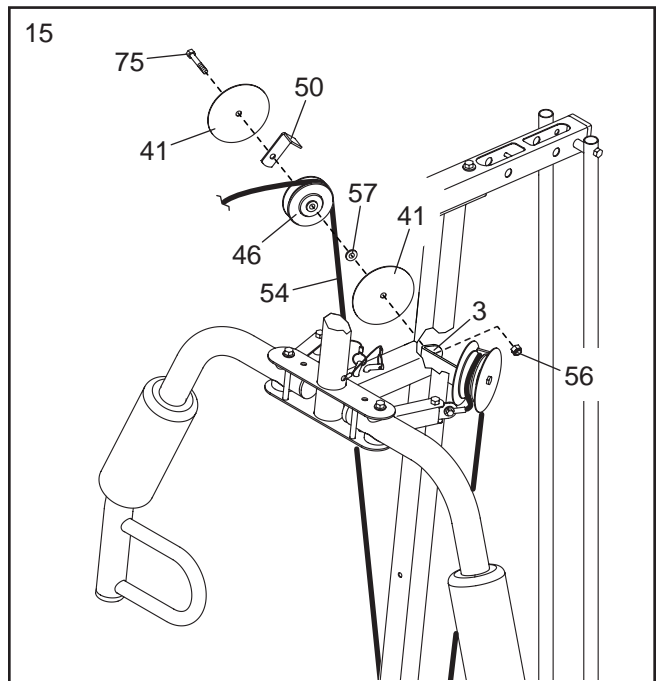

16. Grease an M8 x 22mm Shoulder Bolt (65).

Attach the Arm Cable (54) to the indicated Cable Pivot (39) with the M8 x 22mm Shoulder Bolt (65) and an M8 Locknut (58). **Make sure that the cable end can pivot easily on the Shoulder Bolt.**

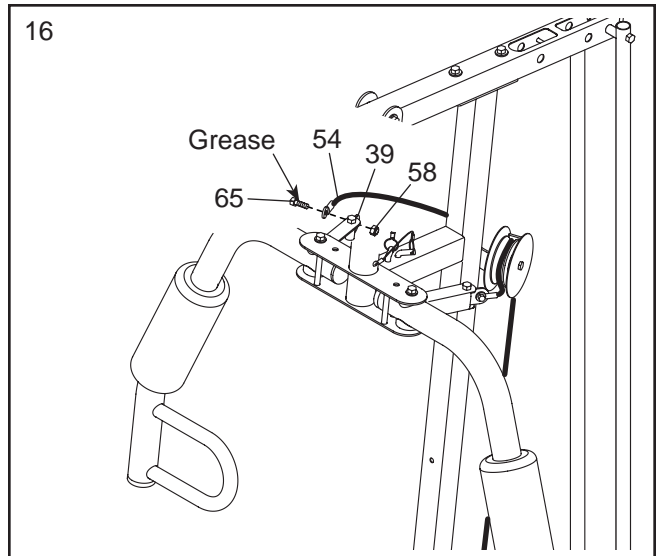

17. See the CABLE DIAGRAM. Identify the Low Cable (53).

Route the Low Cable (53) through the Leg Lever (8) and the Front Leg (7). **Make sure that the eyelet end (G) of the Low Cable is in the location shown.**

Then, attach a Pulley (48) inside the Leg Lever (8), **above** the Low Cable (53), with an M10 x 67mm Bolt (71), two M10 Washers (57), two 12mm Spacers (52), and an M10 Locknut (56).

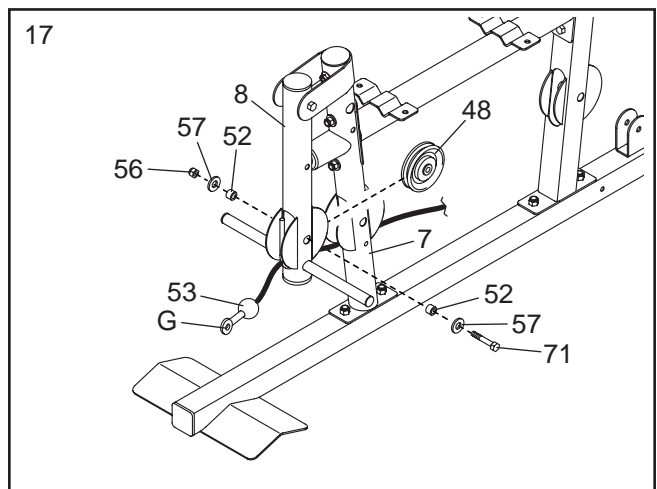

18. Attach a Pulley (48) inside the Front Leg (7), **above** the Low Cable (53), with an M10 x 67mm Bolt (71), two M10 Washers (57), two 12mm Spacers (52), and an M10 Locknut (56).

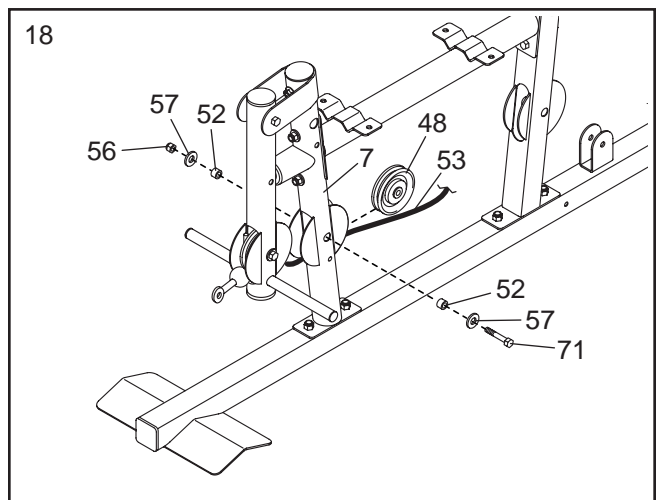

19. Route the Low Cable (53) under a Pulley (48) and through the Upright (3).

Attach the Pulley (48) inside the Upright (3) with an M10 x 67mm Bolt (71), two M10 Washers (57), two 12mm Spacers (52), and an M10 Locknut (56).

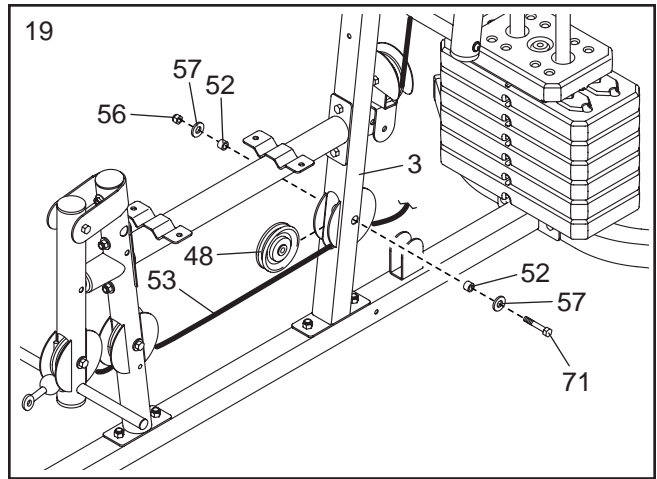

20. Route the Low Cable (53) over a Pulley (48).

Attach the Pulley (48) and two Half Guards (43) to the Double U-bracket (63) with an M10 x 46mm Bolt (81) and an M10 Locknut (56). **Make sure that the Half Guards are on the outside of the U-bracket as shown.**

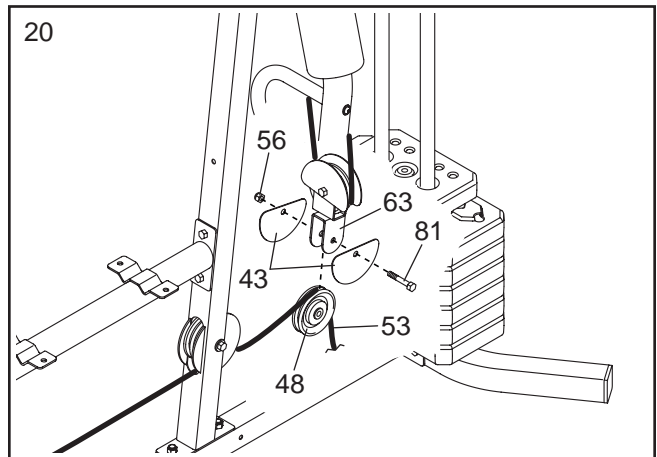

21. Route the Low Cable (53) under a Pulley (48).

Attach the Pulley (48) and two Half Guards (43) to the Base (1) with an M10 x 46mm Bolt (81) and an M10 Locknut (56). **Make sure that the Half Guards are on the outside of the bracket as shown.**

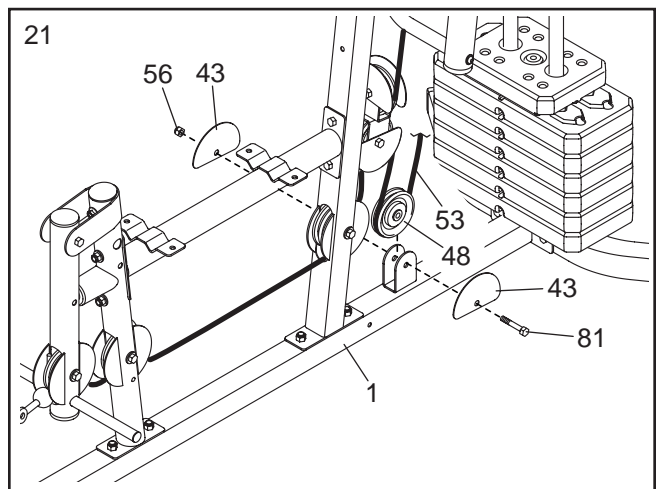

22. Attach the Low Cable (53) to the U-bracket (45) with an M8 Washer (59) and an M8 Locknut (58).

**See the inset drawing. Do not overtighten the M8 Locknut (58); it should be threaded onto the end of the Low Cable (53) so that only two threads are showing above the Locknut.**

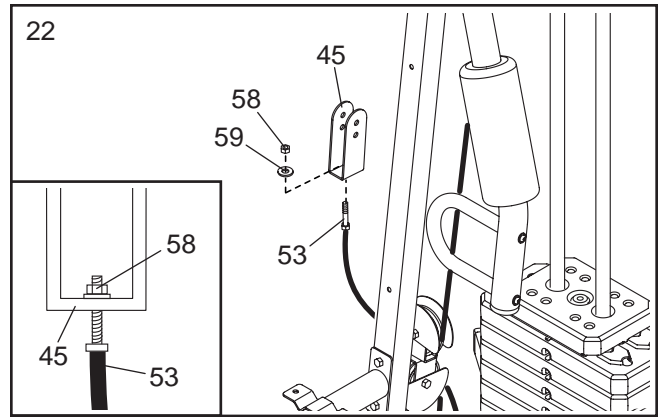

23. See the CABLE DIAGRAM. Identify the High Cable (55).

Route the High Cable (55) upward through the Top Frame (4) and over a Pulley (48). **Make sure that the eyelet end (H) of the High Cable is in the location shown.**

Attach the Pulley (48) inside the Top Frame (4) with an M10 x 67mm Bolt (71), two M10 Washers (57), two 12mm Spacers (52), and an M10 Locknut (56).

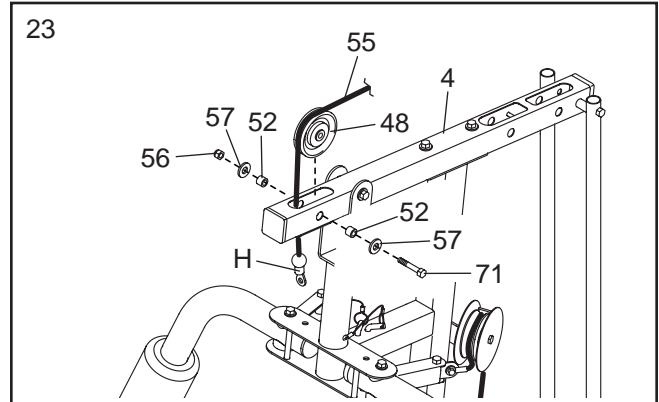

24. Route the High Cable (55) over a Thin Pulley (47) and downward through the Top Frame (4).

Attach the Thin Pulley (47) inside the Top Frame (4) with an M10 x 67mm Bolt (71), an M10 Washer (57), and an 11mm Spacer (49). **Make sure that the Thin Pulley does not fall out of the Top Frame while you complete steps 25 and 26.**

Note: Another Thin Pulley (not shown) will be installed inside the Top Frame (4) with the same M10 x 67mm Bolt (71) in step 26.

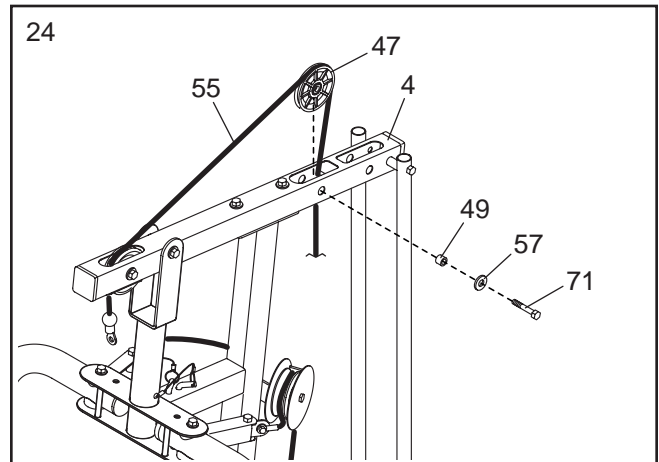

25. Wrap the High Cable (55) under a Pulley (48).

Attach the Pulley (48), a Cable Trap (51), and two Half Guards (43) to the **upper hole** in the U-bracket (45) with an M10 x 51mm Bolt (66) and an M10 Locknut (56).

**Make sure that the Small Cable Trap (51) is oriented to hold the High Cable (55) in the groove of the Pulley (48) and that the Half Guards (43) are on the outside of the U-bracket (45).**

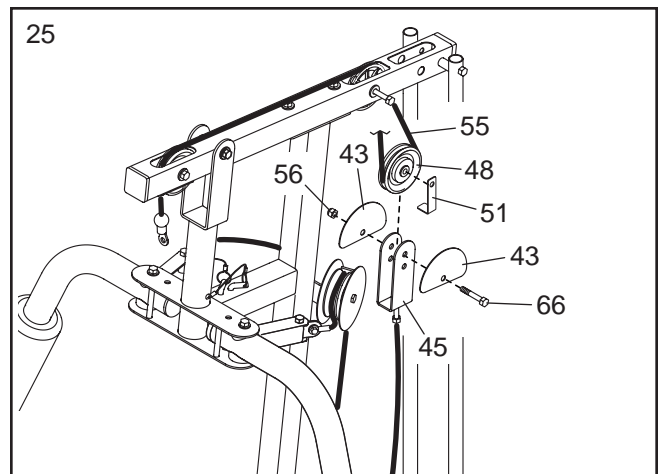

26. Route the High Cable (55) upward through the Top Frame (4) and over a Thin Pulley (47).

Attach the Thin Pulley (47) inside the Top Frame (4) with the M10 x 67mm Bolt (71) used in step 24, an 11mm Spacer (49), an M10 Washer (57), and an M10 Locknut (56).

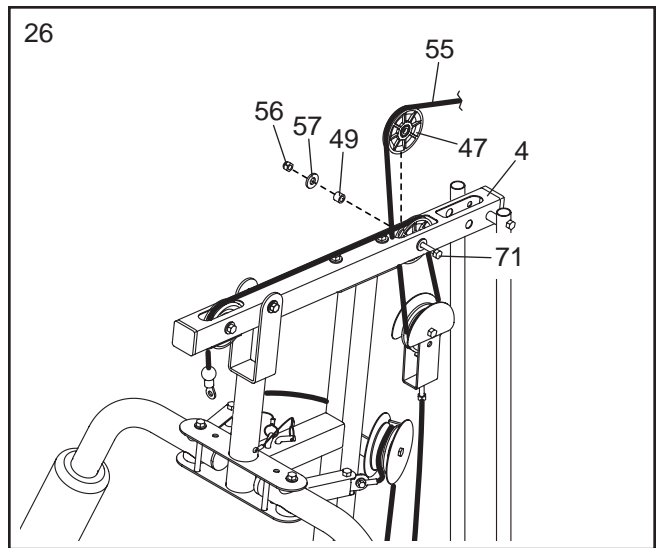

27. Route the High Cable (55) over a Pulley (48) and downward through the Top Frame (4).

Attach the Pulley (48) inside the Top Frame (4) with an M10 x 67mm Bolt (71), two M10 Washers (57), two 12mm Spacers (52), and an M10 Locknut (56).

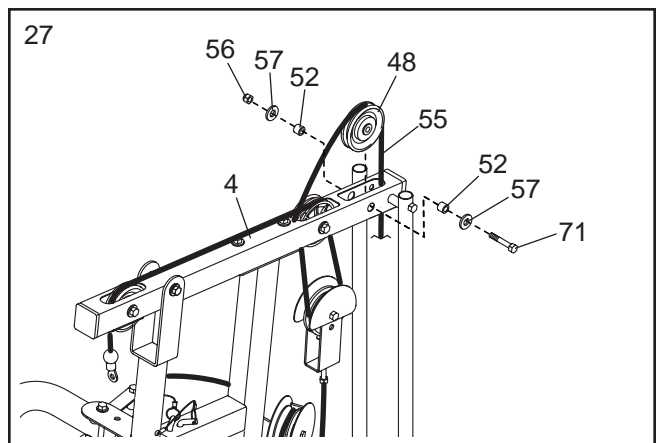

28. Thread an M12 Nut (82) all of the way onto the end of the High Cable (55).

Next, place a Large Washer (78) on top of the Weight Selector (24).

Tighten the High Cable (55) into the Weight Selector (24) until all of the slack is removed from the cables.

Then, tighten the M12 Nut (82) against the Large Washer (78).

**Tip: If the High Cable (55) does not reach to the Weight Selector (24), see step 22.** If more than two threads of the Low Cable (53) are showing above the M8 Locknut (58), adjust the Locknut so that only two threads of the Low Cable are showing.

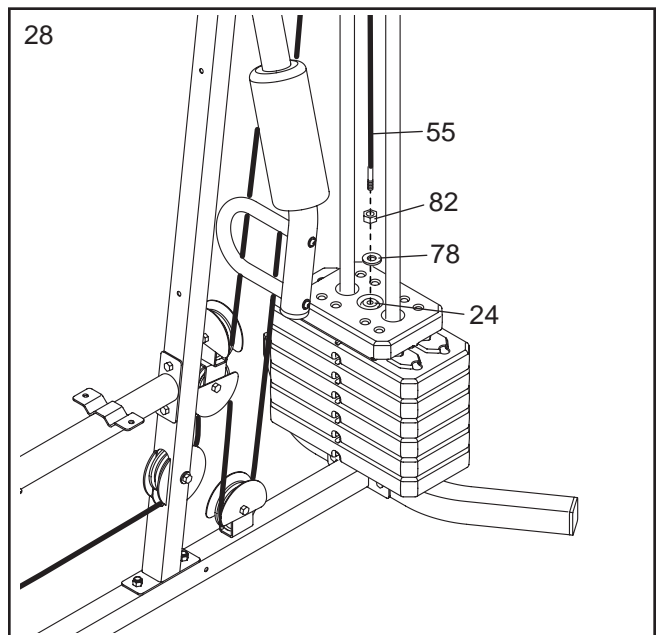

## Seat Assembly

29. Attach the Backrest (16) to the Upright (3) with two M6 x 63mm Screws (70) and two M6 Washers (80).

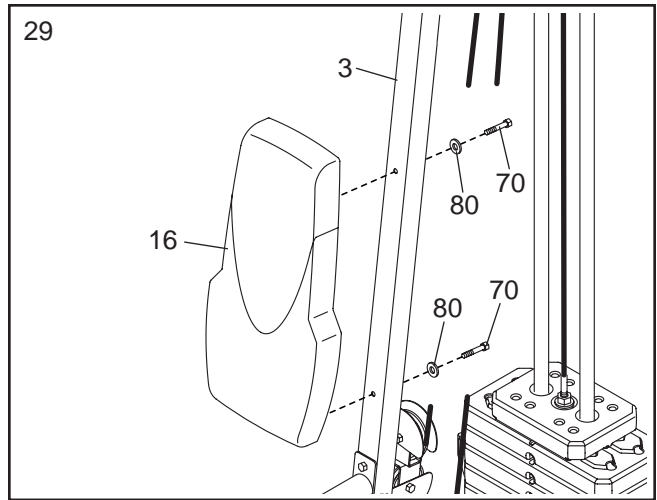

30. Attach the Seat (15) to the Seat Frame (6) with four M6 x 16mm Screws (62).

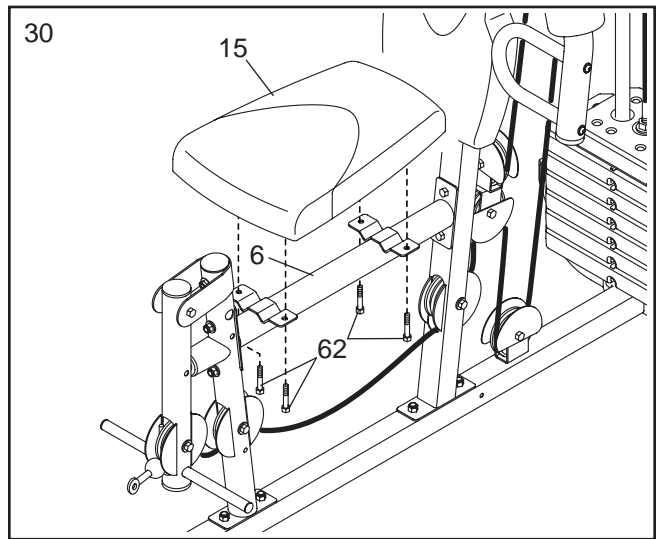

31. Attach the Lock Plate (73) to the Front Leg (7) with an M10 x 70mm Bolt (72), an M10 Washer (57), and an M10 Locknut (56). **Do not overtighten the Locknut; the Lock Plate must pivot easily.**

Next, attach the Leg Lever Pin (38) to the Front Leg (7) with an M4 x 20mm Self-tapping Screw (69).

Then, insert the Leg Lever Pin (38) through the Leg Lever (8) and the Lock Plate (73).

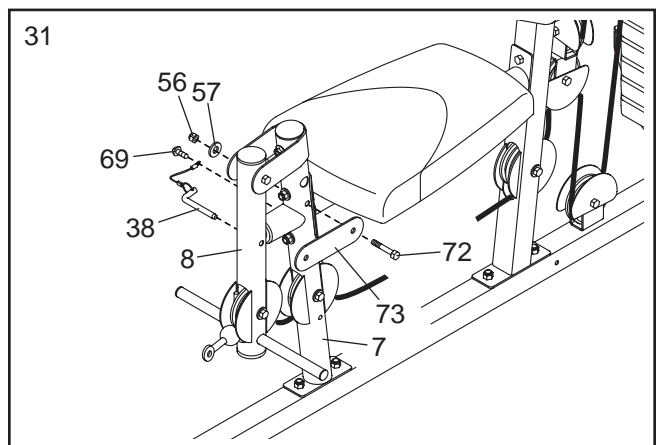



32. Insert the Pad Tube (29) into the Front Leg (7).

Next, slide a Small Foam Pad (28) onto each end of the Pad Tube (29).

Then, slide a Small Foam Pad (28) onto each side of the Leg Lever (8).

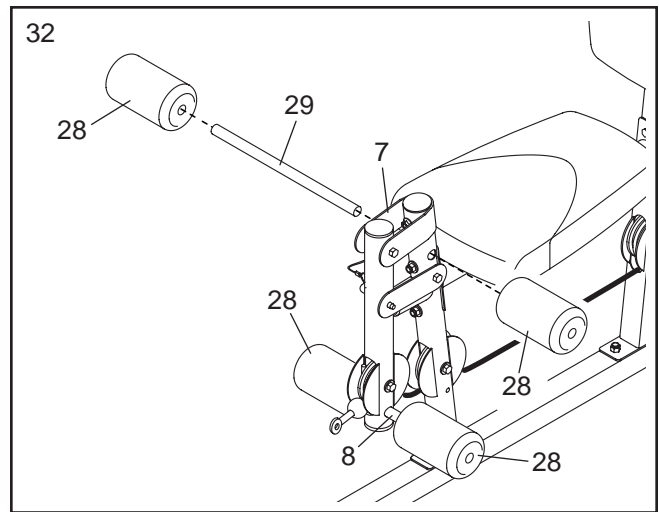

33. Attach the Curl Pad (14) to the Curl Post (13) with two M6 x 16mm Screws (62).

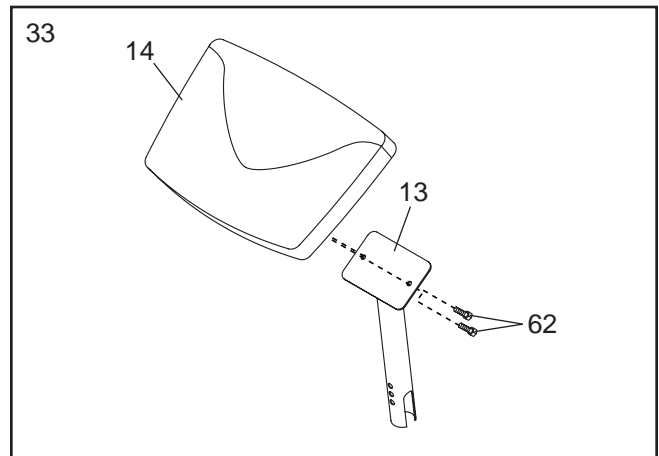

34. Make sure that all parts have been properly tightened. The use of the remaining parts will be explained in ADJUSTMENT, beginning on page 19.

Before using the weight system, pull each cable a few times to make sure that the cables move smoothly around the pulleys. If one of the cables does not move smoothly, find and correct the problem.

**IMPORTANT:** If the cables are not properly installed, they may be damaged when heavy weight is used. See the **CABLE DIAGRAM** on page 22 for proper cable routing. If there is any slack in the cables, you will need to remove the slack by tightening the cables. See **MAINTENANCE** on page 23.

# ADJUSTMENT

This section explains how to adjust the weight system. See the EXERCISE GUIDELINES on page 24 for important information about how to get the most benefit from your exercise program. Also, refer to the accompanying exercise guide to see the correct form for each exercise.

Make sure all parts are properly tightened each time the weight system is used. Replace any worn parts immediately.

## CHANGING THE WEIGHT SETTING

To change the weight setting, insert the Weight Pin (26) under the desired Weight (22); make sure to insert the Weight Pin until the bent end touches the weight stack, and then turn the bent end downward. **IMPORTANT: Do not use the Top Weight (25) by itself.**

**Note: Due to the cables and pulleys, the amount of resistance at each exercise station may vary from the weight setting (see the WEIGHT RESISTANCE CHART on page 21).**

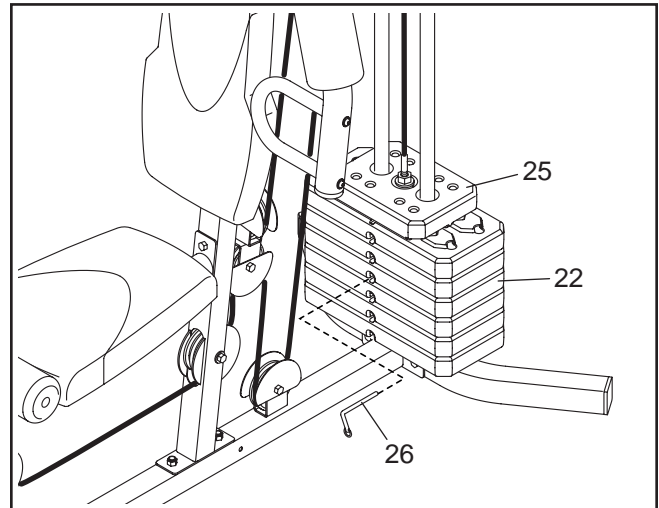

## ATTACHING THE ACCESSORIES TO A PULLEY STATION

Attach the Lat Bar (35) to the High Cable (55) at the high pulley station with a Cable Clip (37).

For some exercises, attach the Chain (19) between the Lat Bar (35) and the High Cable (55) with two Cable Clips. **Adjust the length of the Chain between the Lat Bar and the High Cable so that the Lat Bar is in the correct starting position for the exercise to be performed.**

The Lat Bar (35) or the Handle Strap (not shown) can be attached at either pulley station in the same way. Always engage the Lock Plate (not shown) before using the low pulley station (see USING THE LEG LEVER on page 20).

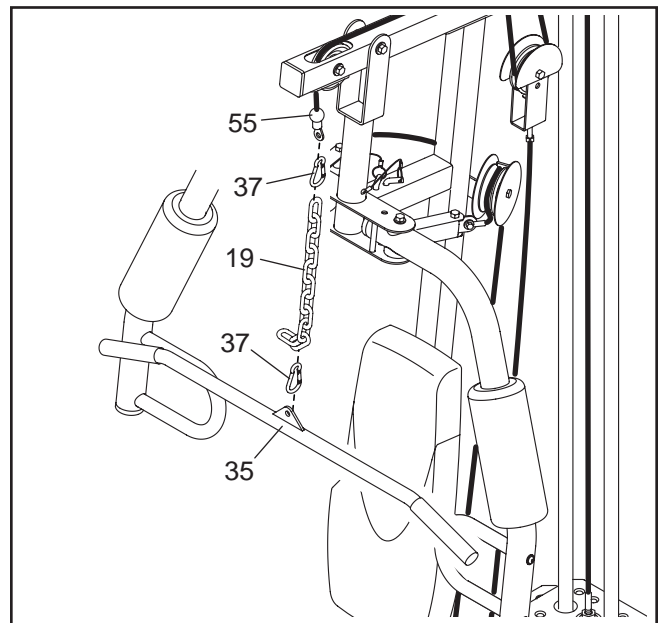

## USING THE LEG LEVER

To use the Leg Lever (8), pull the Leg Lever Pin (38) out of the Leg Lever and the Lock Plate (73).

To use the low pulley station, insert the Leg Lever Pin (38) fully into the Leg Lever (8) and the Lock Plate (73).

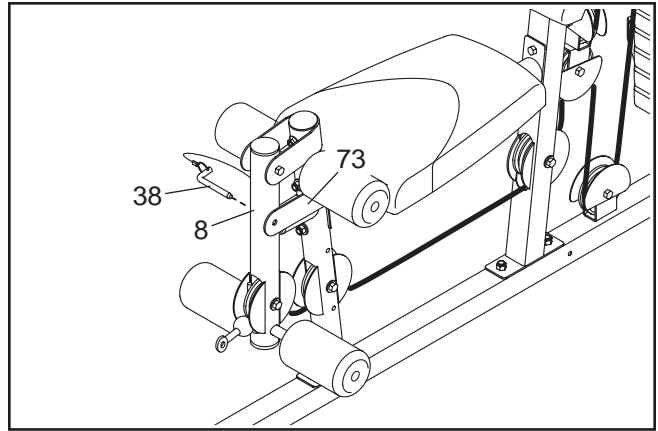

## CONVERTING THE ARMS

To use the Arms (9, 10) as butterfly arms, insert the Arm Pins (40) into the holes (A) in the Upright (3) and the Pivot Frame (5) as shown.

To use the Arms (9, 10) as press arms, insert the Arm Pins (40) into the holes in the Pivot Frame (5) and the Arms.

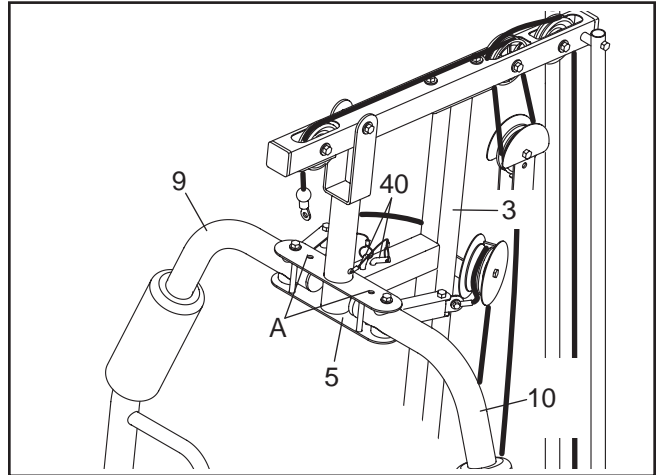

## USING THE CURL PAD

To use the Curl Pad (14), remove the 50mm Round Inner Cap (30) from the Front Leg (7). Insert the Curl Post (13) into the Front Leg and secure it in place with the Curl Knob (61).

Before performing an exercise that does not require the Curl Pad (14), remove the Curl Pad and press the 50mm Round Inner Cap (30) into the Front Leg (7). Store the Curl Pad away from the weight system.

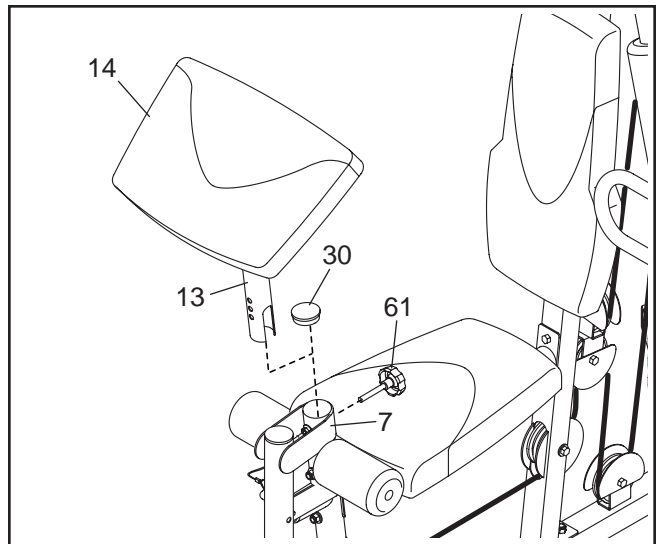

## LOCKING THE WEIGHT STACK

To lock the weight stack, insert the Lock Pin (18) into a Weight Guide (21) and attach the Lock (17) to the Lock Pin.

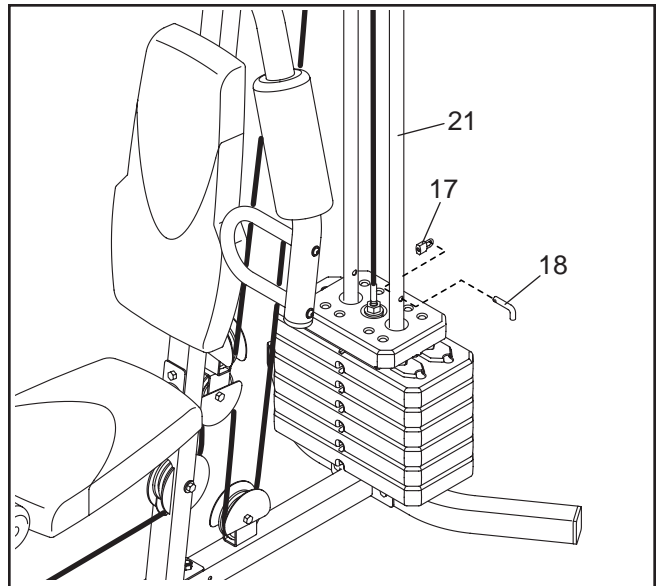

## WEIGHT RESISTANCE CHART

The chart below shows the approximate weight resistance at each exercise station. The numbers in the left column refer to the 12.5-lb. weights. **Note: The weight resistance shown for the butterfly arm station is for each arm. The actual resistance at each station may vary due to differences in individual weights as well as friction between the cables, pulleys, and weight guides.**

| WEIGHT | HIGH PULLEY (lbs.) | BUTTERFLY ARM (lbs.) | PRESS ARM (lbs.) | LEG LEVER (lbs.) | LOW PULLEY (lbs.) |
|--------|--------------------|----------------------|------------------|------------------|-------------------|
| Top    | 11                 | 16                   | 27               | 27               | 26                |
| 1      | 26                 | 22                   | 44               | 57               | 55                |
| 2      | 42                 | 30                   | 62               | 85               | 86                |
| 3      | 61                 | 41                   | 97               | 111              | 119               |
| 4      | 70                 | 51                   | 127              | 159              | 148               |
| 5      | 86                 | 63                   | 144              | 182              | 163               |
| 6      | 101                | 82                   | 173              | 214              | 187               |

Note: 1 lb. = 0.45 kg

# CABLE DIAGRAM

The diagram below shows the proper routing of the cables. The numbers in each drawing show the proper route of that cable. Cut along the dotted line, and refer to this diagram while you assemble the cables and the pulleys. If the cables and the pulleys are not assembled correctly, the weight system will not function properly and damage may occur. **Make sure that the cable traps do not touch or bind the cables. After you assemble the weight system, save this diagram with this manual for future reference.**

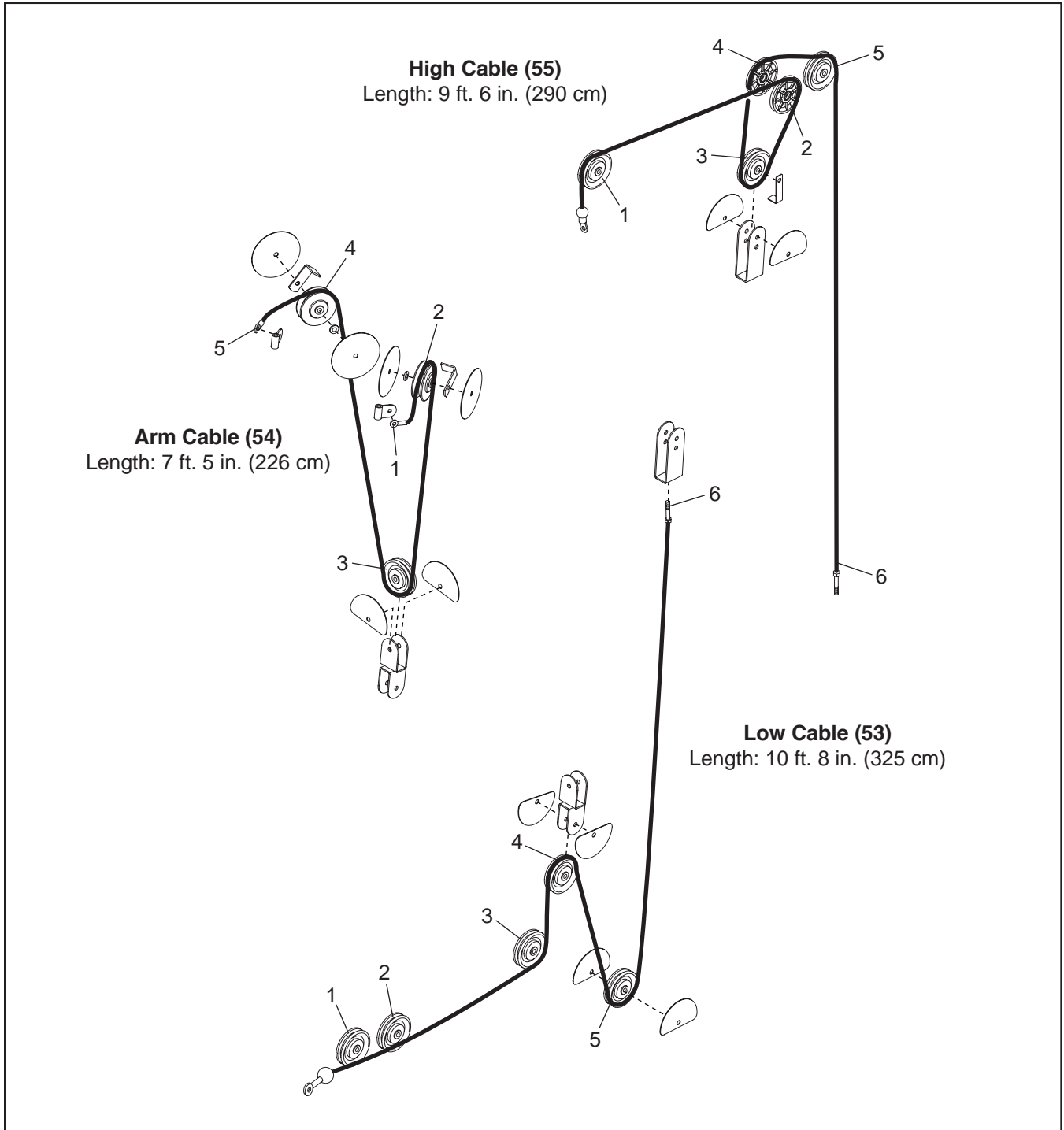

# MAINTENANCE

Make sure that all parts are properly tightened each time the weight system is used. Replace any worn parts immediately. The weight system can be cleaned with a damp cloth and a mild, non-abrasive detergent. Do not use solvents.

## TIGHTENING THE CABLES

Woven cable, the type of cable used on the weight system, can stretch slightly when it is first used. If there is slack in the cables before resistance is felt, the cables should be tightened. To tighten the cables, first insert the weight pin into the middle of the weight stack. Slack can be removed from these cables several ways:

**See the inset drawing.** Tighten the M8 Locknut (58) that connects the end of the Low Cable (53) to the U-bracket (45).

To further tighten the cables, remove the M10 Locknut (56) and the M10 x 51mm Bolt (66) from the Small Cable Trap (51), the Pulley (48), the two Half Guards (43), and the U-bracket (45). Reattach the Pulley, Cable Trap, and Half Guards to the other hole in the U-bracket. **Make sure that the Cable Trap is in the proper position and that the Low Cable (53) and Pulley move smoothly.**

To further tighten the cables, loosen the M12 Nut (82) on the High Cable (55). Next, tighten the High Cable into the Weight Selector (24) until the slack is removed from the High Cable. Then, retighten the M12 Nut against the Large Washer (78).

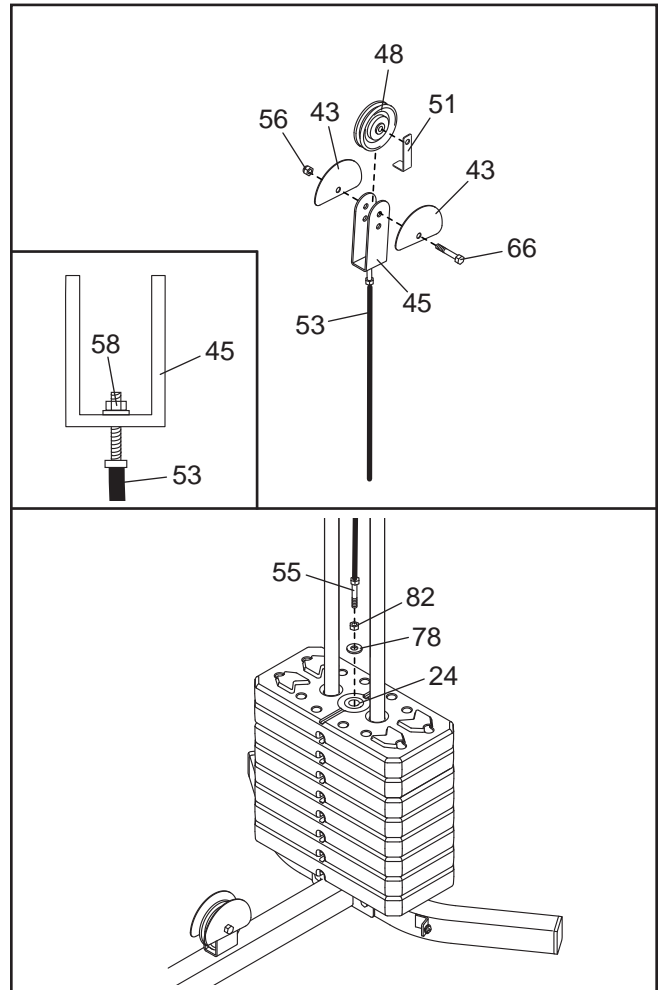

**Do not overtighten the cables. If the cables are overtightened, the top weight will be lifted off the weight stack. If a cable tends to slip off the pulleys often, it may have become twisted. Remove the cable and reinstall it.** If the cables need to be replaced, see ORDERING REPLACEMENT PARTS on the back cover of this manual.

---

# EXERCISE GUIDELINES

## FOUR TYPES OF STRENGTH WORKOUTS

Note: A “repetition” is one complete cycle of an exercise, such as one sit-up. A “set” is a series of repetitions.

**Muscle Building**—Work your muscles near their maximum capacity and progressively increase the intensity of your exercise. Adjust the intensity level of an individual exercise as follows:

- Change the amount of resistance used.
- Change the number of repetitions or sets performed.

Use your own judgment to determine the amount of resistance that is right for you. Begin with 3 sets of 8 repetitions for each exercise that you perform. Rest for 3 minutes after each set. When you can complete 3 sets of 12 repetitions without difficulty, increase the amount of resistance.

**Toning**—Tone your muscles by working them to a moderate percentage of their capacity. Select a moderate amount of resistance and increase the number of repetitions in each set. Complete as many sets of 15 to 20 repetitions as possible without discomfort. Rest for 1 minute after each set. Work your muscles by completing more sets rather than by using high amounts of resistance.

**Weight Loss**—To lose weight, use a low amount of resistance and increase the number of repetitions in each set. Exercise for 20 to 30 minutes, resting for a maximum of 30 seconds between sets.

**Cross Training**—Combine strength training and aerobic exercise by following this type of program:

- Strength workouts on Monday, Wednesday, and Friday.
- 20 to 30 minutes of aerobic exercise on Tuesday and Thursday.
- One full day of rest each week to give your body time to regenerate.

## WORKOUT GUIDELINES

Familiarize yourself with the equipment and learn the proper form for each exercise. Use your own judgment

to determine the appropriate length of time for each workout, and the numbers of repetitions and sets to complete. Progress at your own pace and be sensitive to your body’s signals. Follow each strength workout with at least one day of rest.

**Warming Up**—Start with 5 to 10 minutes of stretching and light exercise. A warm-up increases your body temperature, heart rate, and circulation in preparation for exercise.

**Working Out**—Include 6 to 10 different exercises in each workout. Select exercises for every major muscle group, emphasizing areas that you want to develop. To give balance and variety to your workouts, vary the exercises from workout to workout.

**Cooling Down**—Finish with 5 to 10 minutes of stretching. Stretching increases the flexibility of your muscles and helps to prevent post-exercise problems.

## EXERCISE FORM

Move through the full range of motion for each exercise and move only the appropriate parts of the body. Perform the repetitions in each set smoothly and without pausing. The exertion stage of each repetition should last about half as long as the return stage. Exhale during the exertion stage of each repetition and inhale during the return stroke. Never hold your breath.

Rest for a short period of time after each set:

- Muscle Building—Rest for three minutes after each set.
- Toning—Rest for one minute after each set.
- Weight Loss—Rest for 30 seconds after each set.

## STAYING MOTIVATED

For motivation, keep a record of each workout. Write the date, the exercises performed, the resistance used, and the numbers of sets and repetitions completed. Record your weight and key body measurements once a month. To achieve good results, make exercise a regular and enjoyable part of your life.

# PART LIST

Model No. WESY19318.0 R0619A

| Key No. | Qty. | Description           | Key No. | Qty. | Description                  |
|---------|------|-----------------------|---------|------|------------------------------|
| 1       | 1    | Base                  | 44      | 4    | Arm Bushing                  |
| 2       | 1    | Stabilizer            | 45      | 1    | U-bracket                    |
| 3       | 1    | Upright               | 46      | 2    | V-pulley                     |
| 4       | 1    | Top Frame             | 47      | 2    | Thin Pulley                  |
| 5       | 1    | Pivot Frame           | 48      | 9    | Pulley                       |
| 6       | 1    | Seat Frame            | 49      | 2    | 11mm Spacer                  |
| 7       | 1    | Front Leg             | 50      | 2    | Large Cable Trap             |
| 8       | 1    | Leg Lever             | 51      | 1    | Small Cable Trap             |
| 9       | 1    | Right Arm             | 52      | 10   | 12mm Spacer                  |
| 10      | 1    | Left Arm              | 53      | 1    | Low Cable                    |
| 11      | 2    | Handle                | 54      | 1    | Arm Cable                    |
| 12      | 1    | Square Plate          | 55      | 1    | High Cable                   |
| 13      | 1    | Curl Post             | 56      | 22   | M10 Locknut                  |
| 14      | 1    | Curl Pad              | 57      | 27   | M10 Washer                   |
| 15      | 1    | Seat                  | 58      | 13   | M8 Locknut                   |
| 16      | 1    | Backrest              | 59      | 7    | M8 Washer                    |
| 17      | 1    | Lock                  | 60      | 1    | Leg Bumper                   |
| 18      | 1    | Lock Pin              | 61      | 1    | Curl Knob                    |
| 19      | 1    | Chain                 | 62      | 6    | M6 x 16mm Screw              |
| 20      | 1    | Handle Strap          | 63      | 1    | Double U-bracket             |
| 21      | 2    | Weight Guide          | 64      | 4    | M8 x 63mm Carriage Bolt      |
| 22      | 6    | Weight                | 65      | 2    | M8 x 22mm Shoulder Bolt      |
| 23      | 1    | Weight Selector Cap   | 66      | 3    | M10 x 51mm Bolt              |
| 24      | 1    | Weight Selector       | 67      | 2    | M10 x 85mm Bolt              |
| 25      | 1    | Top Weight            | 68      | 6    | M8 x 65mm Bolt               |
| 26      | 1    | Weight Pin            | 69      | 4    | M4 x 20mm Self-tapping Screw |
| 27      | 2    | Weight Bumper         | 70      | 2    | M6 x 63mm Screw              |
| 28      | 4    | Small Foam Pad        | 71      | 8    | M10 x 67mm Bolt              |
| 29      | 1    | Pad Tube              | 72      | 1    | M10 x 70mm Bolt              |
| 30      | 8    | 50mm Round Inner Cap  | 73      | 1    | Lock Plate                   |
| 31      | 5    | 50mm Square Inner Cap | 74      | 1    | M10 x 155mm Bolt             |
| 32      | 1    | 38mm Square Outer Cap | 75      | 2    | M10 x 63mm Bolt              |
| 33      | 1    | M4 Washer             | 76      | 2    | 19mm Spacer                  |
| 34      | 4    | 19mm Round Inner Cap  | 77      | 4    | M10 x 25mm Screw             |
| 35      | 1    | Lat Bar               | 78      | 1    | Large Washer                 |
| 36      | 2    | Handgrip              | 79      | 2    | M10 x 77mm Bolt              |
| 37      | 3    | Cable Clip            | 80      | 2    | M6 Washer                    |
| 38      | 1    | Leg Lever Pin         | 81      | 3    | M10 x 46mm Bolt              |
| 39      | 2    | Cable Pivot           | 82      | 1    | M12 Nut                      |
| 40      | 2    | Arm Pin               | *       | –    | User's Manual                |
| 41      | 4    | Full Guard            | *       | –    | Exercise Guide               |
| 42      | 2    | Large Foam Pad        | *       | –    | Grease Packet                |
| 43      | 8    | Half Guard            | *       | –    | Assembly Tool                |

Note: Specifications are subject to change without notice. For information about ordering replacement parts, see the back cover of this manual. \*These parts are not illustrated.





# EXPLODED DRAWING B

Model No. WESY19318.0 R0619A

