

# TRUGLO®

WHEN BRIGHTNESS COUNTS™

**CAUTION: BEFORE YOU BEGIN, ALWAYS MAKE SURE THE FIREARM / CROSSBOW IS UN-LOADED / UN-COCKED AND IS SAFE TO HANDLE.**

**ON / OFF / BRIGHTNESS**

Rotate the power adjustment knob and select the lowest brightness setting that still provides good contrast against the target. The higher brightness settings should only be used in bright daylight (otherwise, the reticle may appear distorted).

(On some models the same knob is also used to select the color of the reticle.)

**BATTERY**

Your sight includes a 3-volt lithium battery (CR2032). To replace the battery, rotate the battery cover counter-clockwise and remove. Insert the replacement battery with "+" side facing out. Replace the cover and hand-tighten.

1

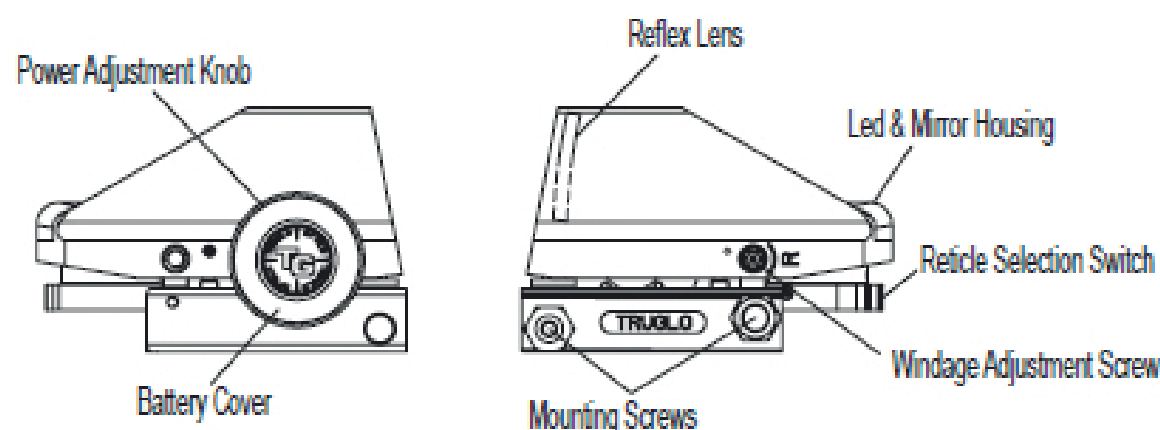

2

**MOUNTING**

Your sight has integrated mounting rails that attach to a standard Weaver-style base or Picatinny rail. If your firearm or crossbow has a smaller 3/8" mounting base, a TRUGLO mounting adaptor can be purchased.

Loosen both mounting screws and set the sight onto the mounting base of the firearm or crossbow. Please note that one mounting screw is lower than the other mounting screw. Only the lower mounting screw should fit into one of the grooves in the top of the mounting base. Be sure the sight is fully seated on the mounting base before tightening the mounting screws. To ensure tightening, alternate between screws after each half turn. (DO NOT OVER-TIGHTEN.) For additional security, a drop of thread-locker can be added to the mounting screws.

3

**PARALLAX**

Your sight has been carefully set to have a minimum parallax at 50 yards (30 yards for crossbow models). At distances significantly greater or less than this distance, some parallax will be observed. To reduce the possibility of a Point of Impact (POI) shift caused by parallax, the reticle should be kept in the middle 2/3 of the field of view when aiming.

**MIRROR ANGLE**

The mirror-lens can be easily seen when looking through the wrong end of the sight. The tilt of the mirror-lens is not a defect. It is tilted to reflect the LED's light back to the user's eye.

**CARE AND MAINTENANCE**

Occasionally clean the lenses with a soft cloth. Always make sure the mounting screws are tight before making windage or elevations adjustments. There are no user serviceable parts inside the sight – any disassembly of the sight will void the warranty.

4

**ZEROING (Initial Setup)**

Please note that the reticle has been pre-set at the factory to be aligned with the mounting base of the sight. Only minor windage and elevation adjustments should be required. If significant adjustments are necessary, please make sure the sight is properly mounted. (This is not a defect with the sight.) Adjustable mounting base may be required for certain firearms and crossbows.

If possible, a bore sighting device should be used for rough alignment of the sight to the firearm or crossbow. If bore sighting is not possible, place the firearm or crossbow on a sturdy rest and look through the barrel or along the rail at a small target about 50 yards away. Remove the elevation and windage protective caps and adjust the windage and elevation screws until the position of the reticle corresponds to the target when viewed through the barrel or along the rail.

5

**CAUTION: ALWAYS USE EYE AND EAR PROTECTION. SHOOT ONLY AT AN APPROVED SHOOTING RANGE OR A SUITABLE SAFE AREA.**

**ZEROING (Final Setup – Live Firing)**

After carefully firing three shots at the target, make any necessary adjustments to the windage and elevation adjustment screws.

One click of elevation or windage moves the Point of Impact (POI) approximately one MOA (1" at a distance of 100 yards, or 3/4" at 75 yards, or 1/2" inch at 50 yards, etc.). The arrows near the adjustment screws indicate the direction of change for the POI (turning the windage screw in the direction marked "R" moves the POI to the right; turning elevation screw in the direction marked "UP" moves the POI up).

6

**RETICLE (Standard Models)**

The four reticle patterns illustrated below can be chosen by moving the reticle selection switch on the back of the sight.

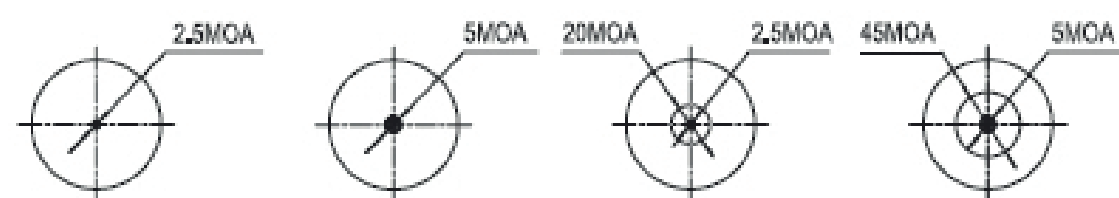

7

Always select the lowest brightness setting that still provides good contrast against the target. The higher brightness settings should only be used in bright daylight (otherwise, the reticle may appear distorted).

Knowing that one MOA is about 1" at a distance of 100 yards (or 3/4" at 75 yards, 1/2" inch at 50 yards, etc.), these reticles can also be used to estimate the distance to a target or even the pattern of a shotgun at a given distance. Choose the reticle that best suits the application, and then test at various distances to achieve the best results.

8

**RETICLE (Crossbow Models)**

The four reticle patterns can be chosen by moving the reticle selection switch on the back of the sight. The reticle patterns correspond to the following approximate speeds using a 400 grain bolt / arrow.

- Reticle Setting "A": approximately 300 fps.
- Reticle Setting "B": approximately 325 fps.
- Reticle Setting "C": approximately 350 fps.
- Reticle Setting "D": approximately 400 fps.

Choose the reticle setting that best suits your crossbow, and then test at various distances to achieve the best results. When switching between reticle settings, it may be necessary to re-sight the top aiming point at 20 yards.

9

The below yardages are only approximate (factors includes bolt / arrow weight, poundage, etc.).

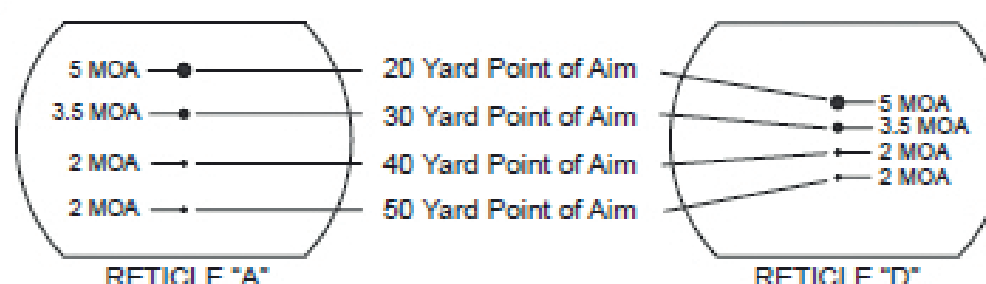

Always select the lowest brightness setting that still provides good contrast against the target. The higher brightness settings should only be used in bright daylight (otherwise, the reticle may appear distorted).

10