

## Thule Chariot Ski kit

# > Instructions

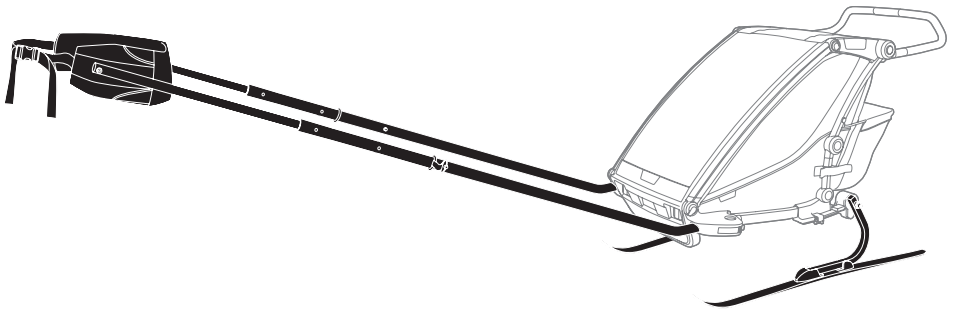

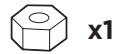
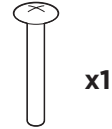
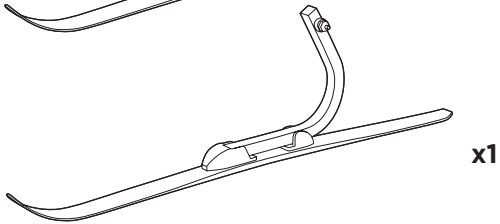
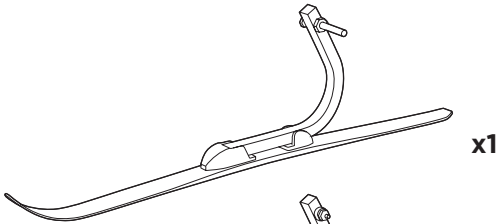
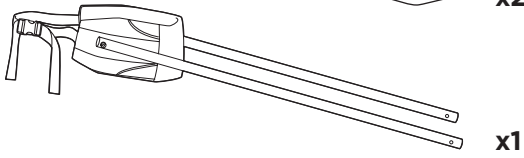
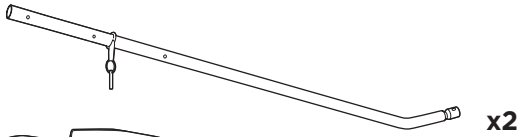

1

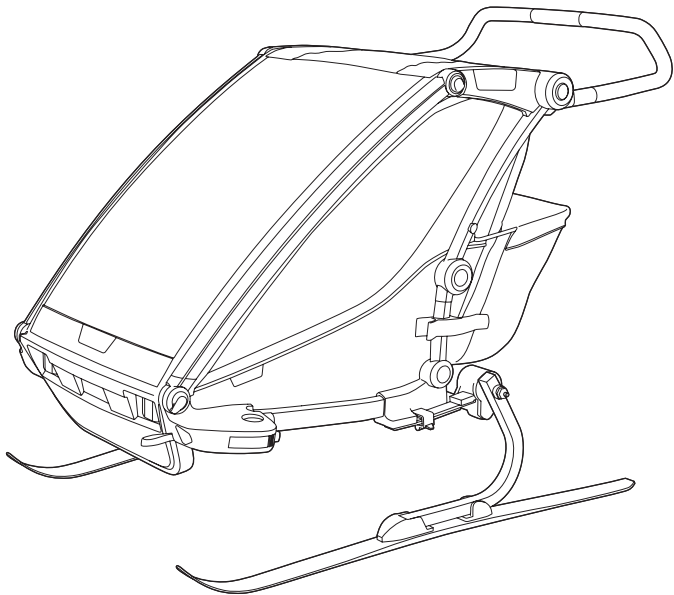
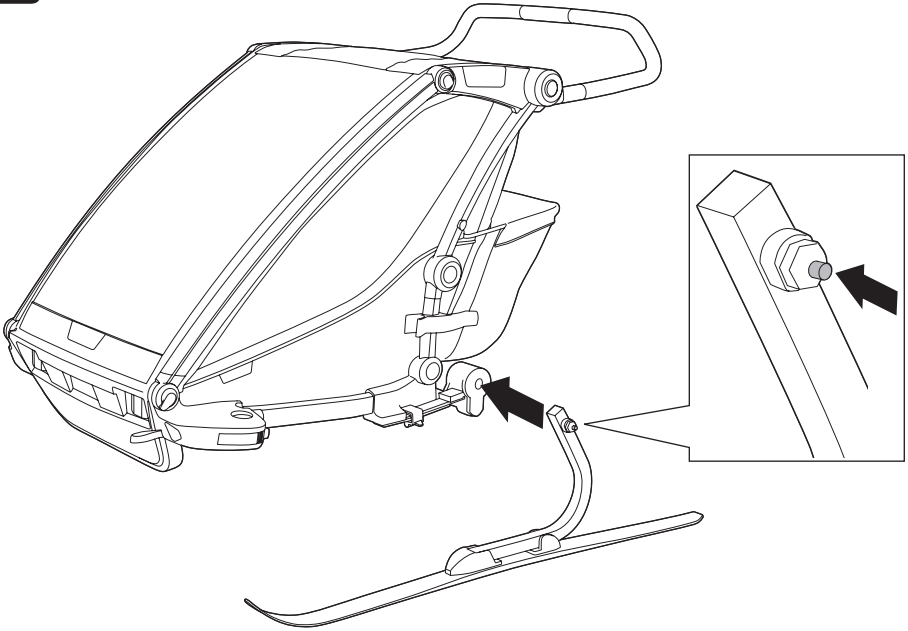

A

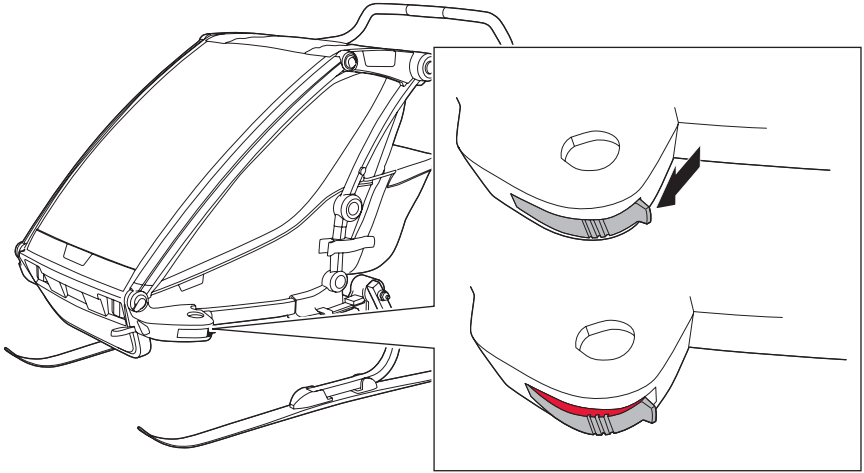

B

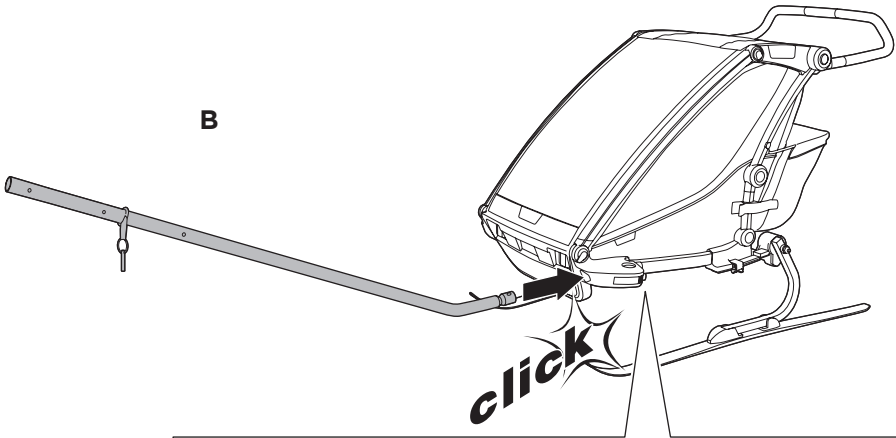

C

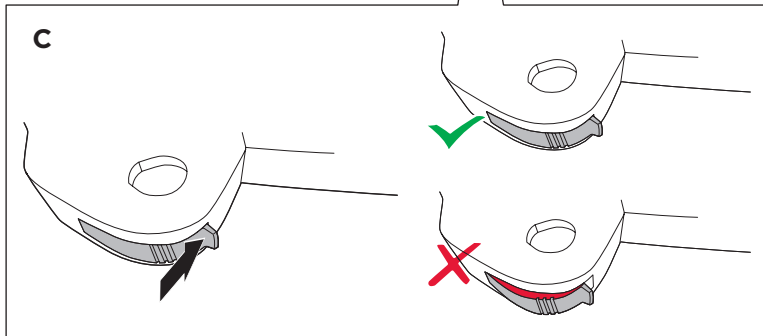

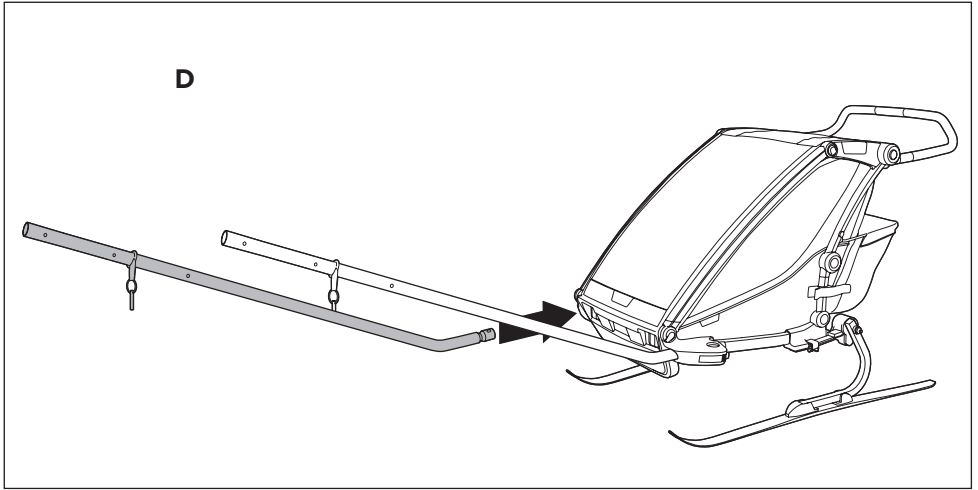

**2b**

Thule Chariot CX  
Thule Chariot Cougar

Thule Chariot Cheetah  
Thule Chariot Corsaire

**A**

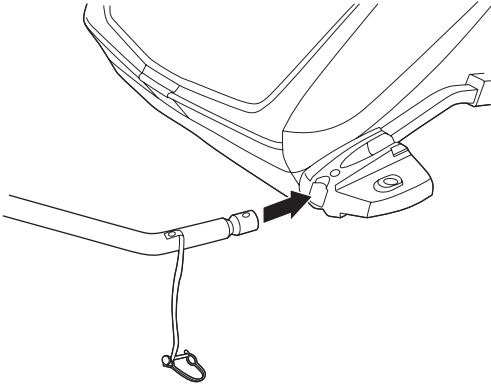

**B**

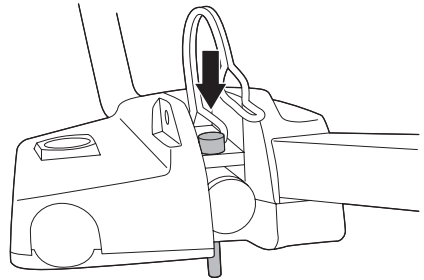

**C**

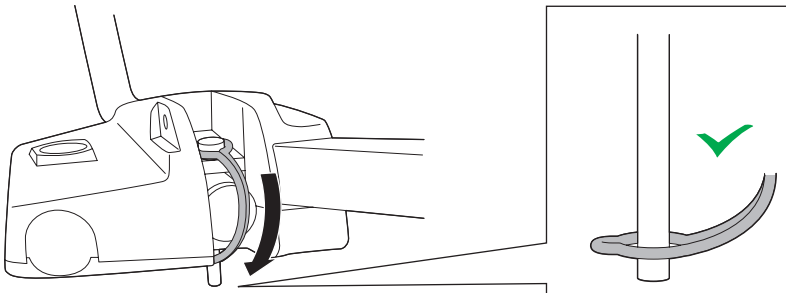

3

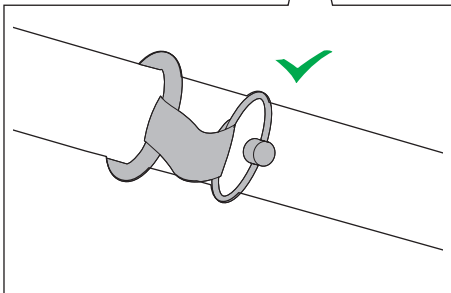
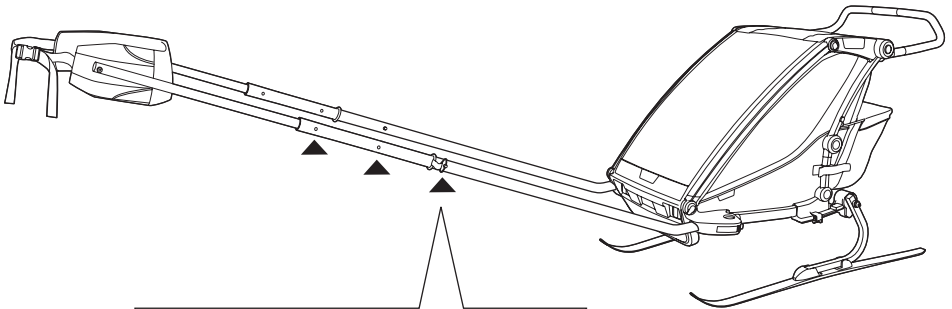
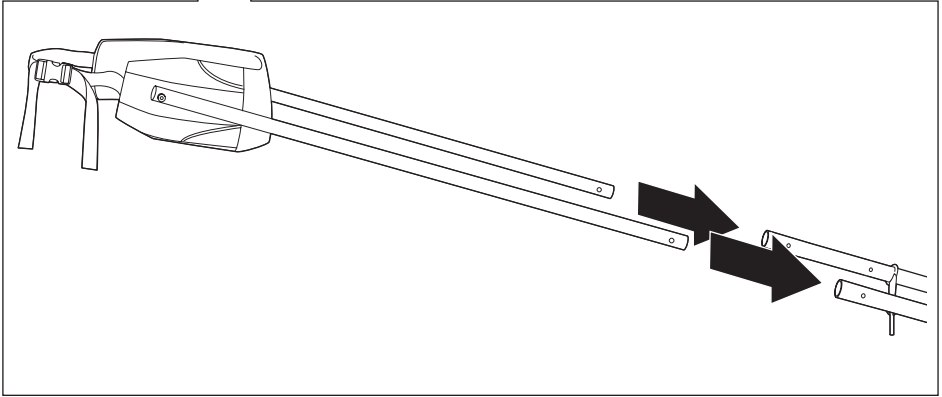
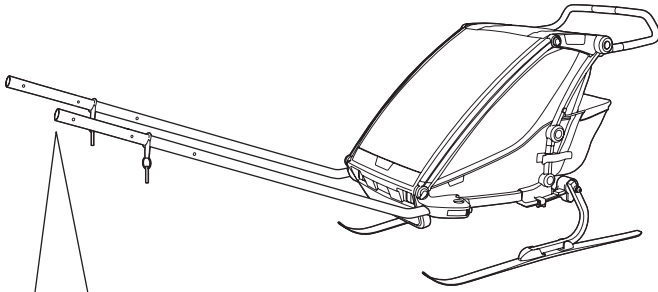

4

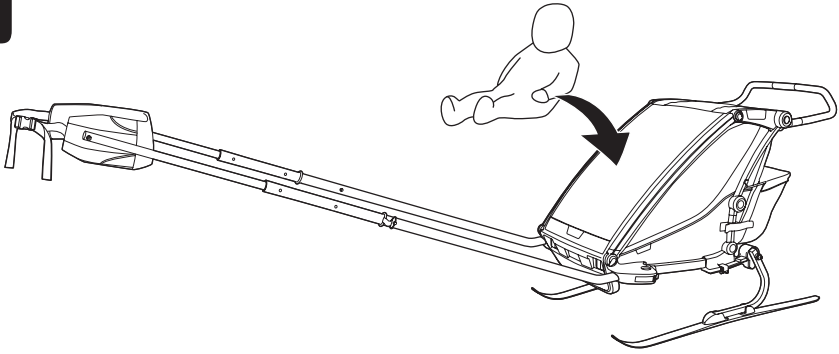

5

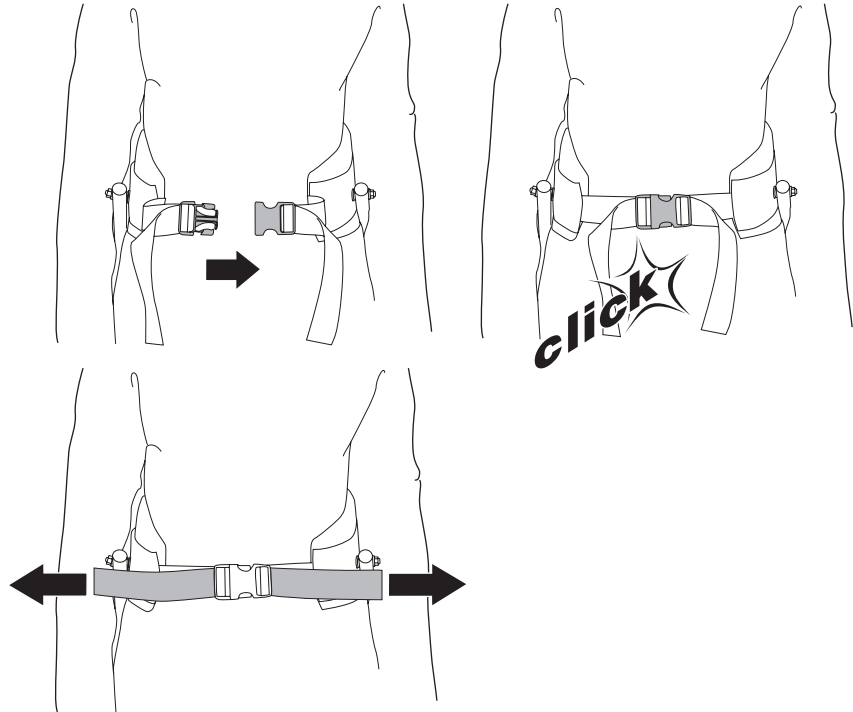
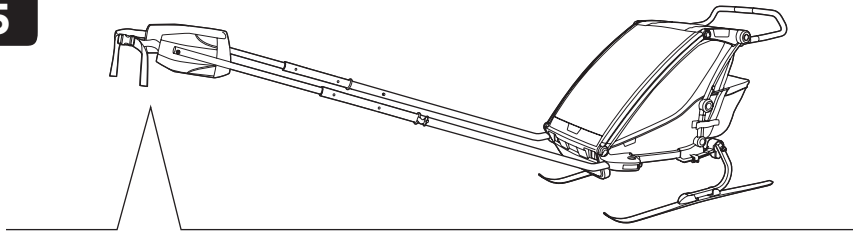

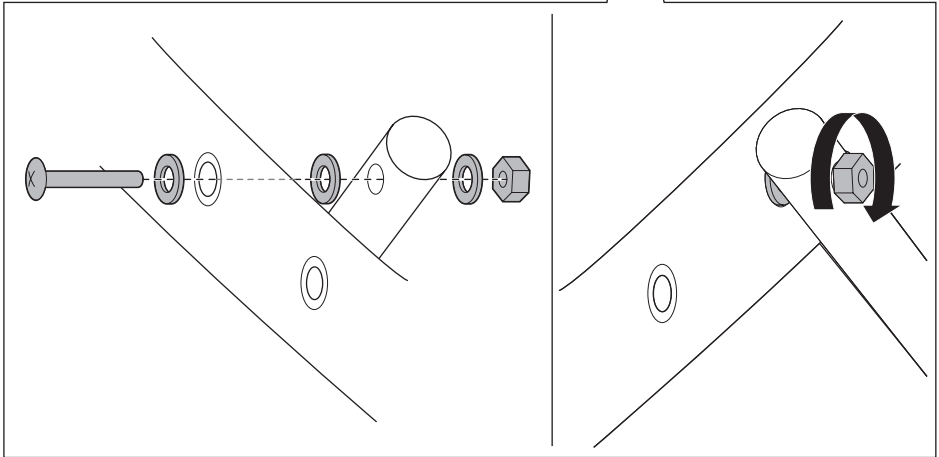
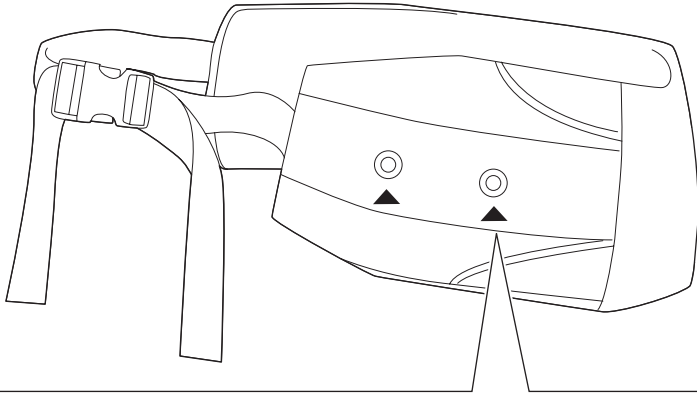



**i**

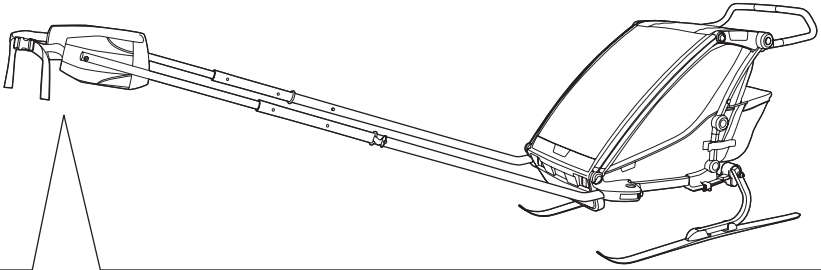

**A**

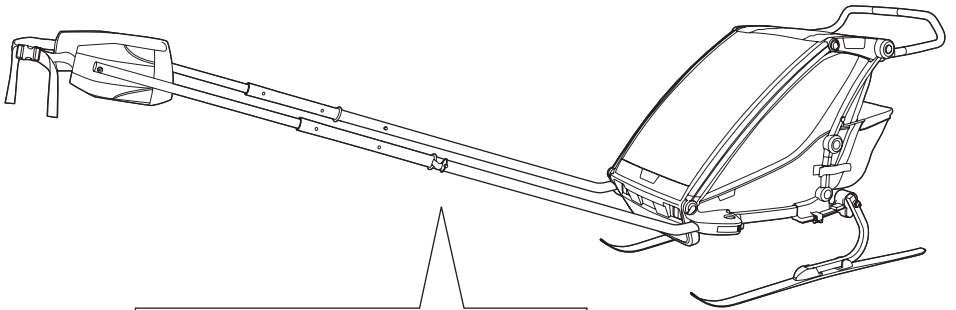
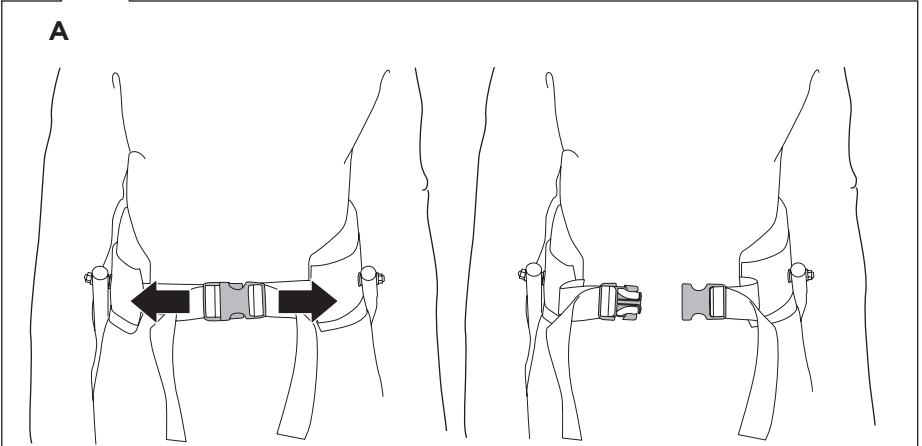

**B**

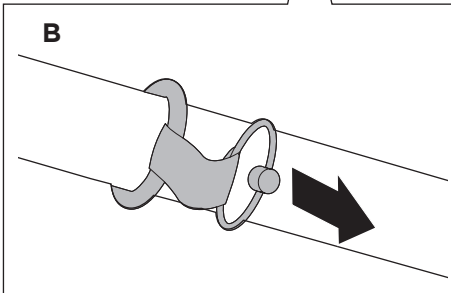

**C**

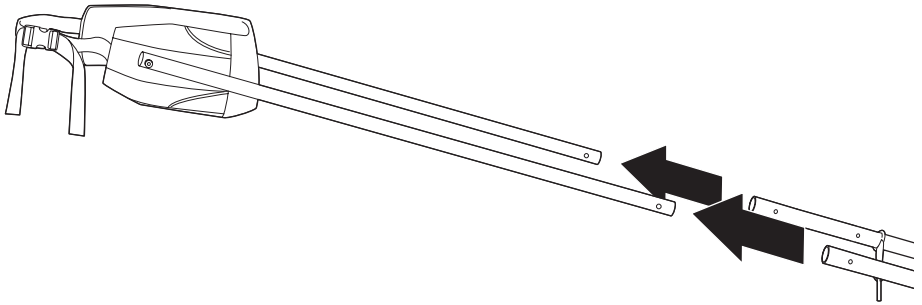

**D**

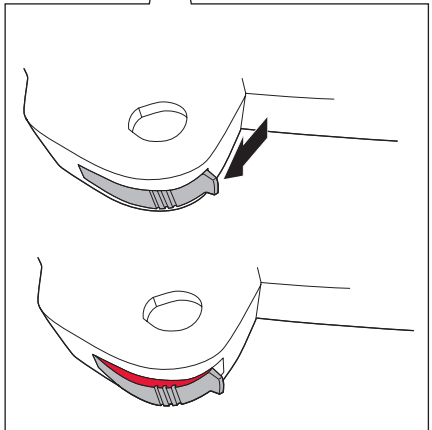
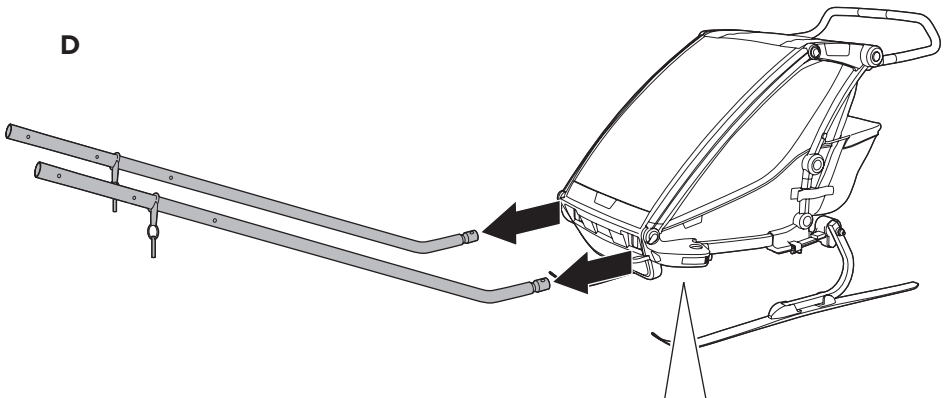

E

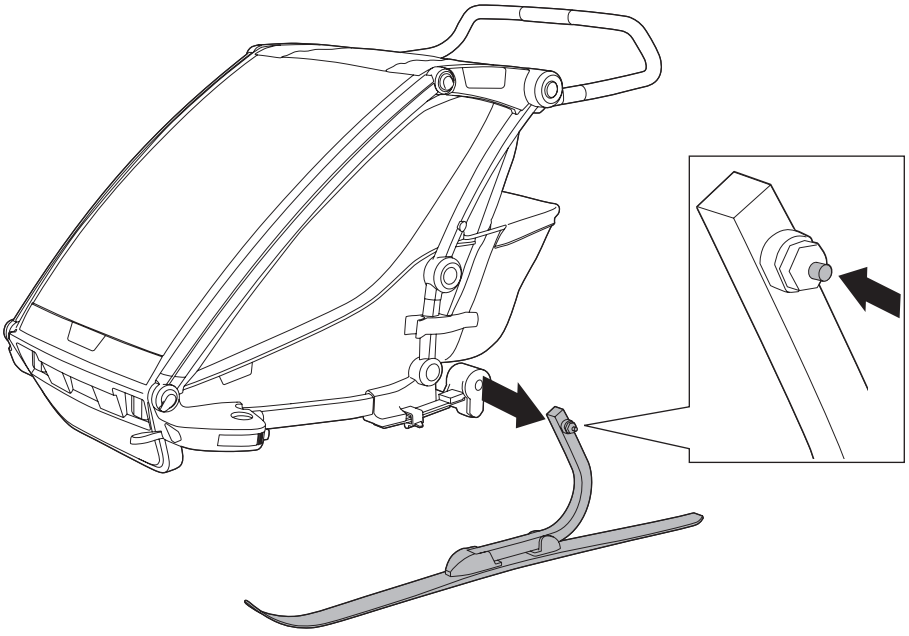



## **WARNING:**

Before each journey check that all components are properly fitted, particularly the skis and the skiing arms.

- Avoid steep inclines, use extreme caution on slopes, uneven terrain, and when stopping.
- Never use this cross-country ski kit for down-hill skiing and never tow it behind a snow mobile or other motorized vehicle.
- Regularly monitor your child(ren) to ensure they are comfortable and warm.