



# WILD ONES™

## LEARN TO BALANCE SCOOTER



# MANUAL

**Read and understand this entire manual before allowing child to use this product! For assistance contact Razor. DO NOT RETURN TO STORE.**

**NOTE: Manual illustrations are for demonstration purposes only. Illustrations may not reflect exact appearance of actual product. Specifications subject to change without notice.**

# CONTENTS

Safety Warnings .....	1	Usage .....	5
Before You Begin.....	2	Repair and Maintenance.....	5
Assembly and Set-Up.....	3-4	Product Parts .....	6
Pre-Ride Checklist.....	5	Warranty and Contact Information .....	7

# SAFETY WARNINGS

## **⚠ IMPORTANT MESSAGE FOR PARENTS ABOUT RAZOR'S NEW WILD ONES "FIRST SCOOTER" TOYS:**

The Razor Wild Ones toy scooter is intended to allow parents to introduce younger children aged 30+ months to scooters, and assist them to learn and enjoy their early riding experiences. Razor's Wild Ones employ slow rolling, very wide, flat-surfaced inline wheels which enable the product to stand on its own and provide some assistance in learning basic balancing. The lowered deck also supports learning to balance, allowing the rider to keep one foot in contact with the ground and the other on the product deck while shifting their weight. With guidance and experience, most children over time will develop the balance and coordination to operate "narrow wheeled" 2-wheel scooters like the original Razor A kick scooter. Adult supervision is essential because young children do not understand the risks of riding in areas with cars and are at a high risk of falling and injuring themselves.

This manual contains important information. For your child's safety, it is your responsibility to review this information and make sure that you instruct your child to follow all warnings, cautions, instructions and safety topics. Razor USA recommends that you periodically review and reinforce the information in this manual with younger riders, and that you inspect and maintain your child's scooter to ensure their safety.

**⚠ GENERAL WARNING:** Scooter riding can be a hazardous activity. Certain conditions may cause the equipment to fail without fault of the manufacturer. Scooters can and are intended to move, and it is therefore possible to get into dangerous situations and/or lose control and/or fall. If such things occur you can be seriously injured or die. LIKE ANY OTHER MOVING PRODUCT, USING A SCOOTER CAN BE A DANGEROUS ACTIVITY AND MAY RESULT IN INJURY OR DEATH EVEN WHEN USED WITH PROPER SAFETY PRECAUTIONS. USE AT YOUR OWN RISK AND USE COMMON SENSE.

This manual contains many warnings and cautions concerning the consequences of failing to maintain, inspect or properly use your Razor scooter. Because any incident can result in serious injury or even death, we do not repeat the warning of potential serious injury or death each time such a possibility is mentioned.

- Do not allow children under age 30+ months to use the scooter. Close adult supervision is required.
- Always pay attention to where your child is going; do not allow child to ride on streets or around cars.
- Always wear safety equipment, such as helmet, knee pads and elbow pads. Always wear a helmet when riding the scooter and keep the chinstrap securely buckled.
- Always wear closed toe shoes.
- Ride on smooth, solid surfaces without loose debris, such as rocks or gravel, and away from motor vehicles.
- Avoid sharp bumps, drainage grates, and sudden surface changes as scooter may suddenly stop.
- Do not ride at night or when visibility is impaired.
- Avoid excessive speed associated with downhill rides.
- Watch out for pedestrians.
- The fender over the rear wheel is not a brake. It is meant to prevent shoe contact with a moving wheel. The product is designed to move slowly and requires no operation of a brake to stop.
- Do not exceed 44 lb (20 kg) total weight on the Razor scooter.
- Rider weight does not necessarily mean a child's size is appropriate to fit or maintain control of the scooter.
- A parent's decision to allow his or her child to ride this product should be based on the child's maturity, skill and ability to follow rules.

## **ACCEPTABLE RIDING PRACTICES AND CONDITIONS**

Direct parental supervision is required at all times. Scooters are meant to be used only in controlled environments, free of potential traffic hazards and not on public streets. Do not allow your child to ride a scooter in any areas where vehicle traffic is present. Child must maintain a hold on the handlebars at all times. Never allow more than one child at a time to ride a scooter. Never use near steps, sloped driveways, hills, roadways, alleys or swimming pool areas.

## **PROPER RIDING ATTIRE**

Always ensure child is wearing proper protective equipment, such as an approved safety helmet. A helmet may be legally required by local law or regulation in your area. A child should always wear shoes, never ride barefooted or in sandals, and keep shoelaces tied and out of the way of the wheels. Knee pads and elbow pads are recommended.

**FAILURE TO USE COMMON SENSE AND HEED THE ABOVE WARNINGS FURTHER INCREASES RISK OF SERIOUS INJURY. USE AT YOUR OWN RISK AND WITH APPROPRIATE AND SERIOUS ATTENTION TO SAFE OPERATION. USE CAUTION.**

**⚠ WARNING:** ALWAYS INSPECT SCOOTER PRIOR TO RIDING. Properly inspecting and maintaining your scooter can reduce the risk of injury. Always inspect your scooter before riding and regularly maintain it. Replace worn parts when they occur.

**⚠ WARNING:** CHECK LOCAL LAWS REGARDING SCOOTER USE. Check local laws and regulations to see where and how you may use your scooter legally. In many states and local areas scooter riders are required BY LAW to wear a helmet. Check local laws and regulations regarding laws governing helmet use and scooter operation in your area.

# BEFORE YOU BEGIN

Adult assembly required. Remove contents from box. Inspect the contents for scratches in the paint and/or dents that may have occurred during shipping. Because your scooter was partially assembled and packed at the factory, there should not be any problems, even if the box has a few scars or dents.

**⚠ WARNING: DO NOT USE NON-RAZOR PRODUCTS WITH YOUR RAZOR SCOOTER.** Razor scooters have been built to certain Razor design specifications. The original equipment supplied at the time of sale was selected on the basis of its compatibility with the frame and all other parts. Certain aftermarket products may not be compatible and will void the warranty.

**Product ID Locations:**  
**See locations to the left**

1. Deck (underneath unit)
2. Box - side of UPC (not shown)

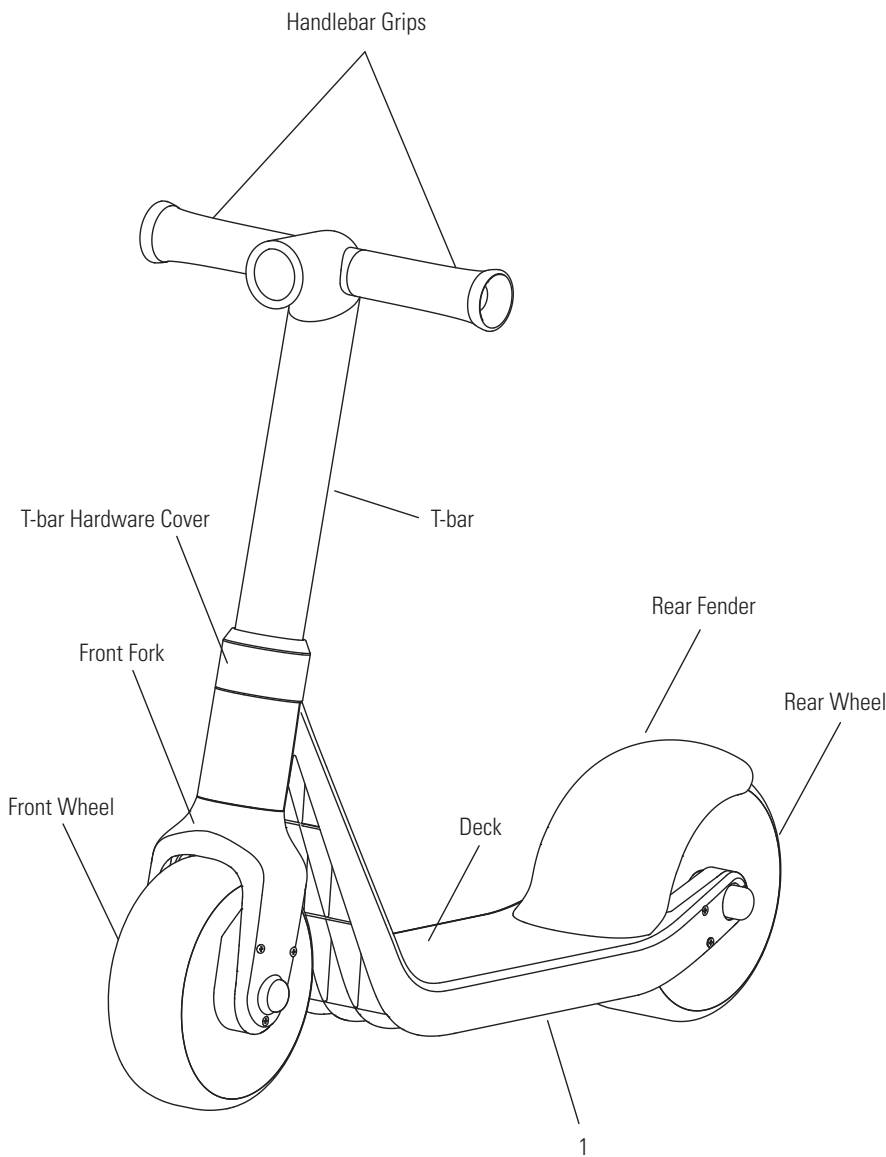

## ▣ Required Tools



Philips Screwdriver  
(Included)

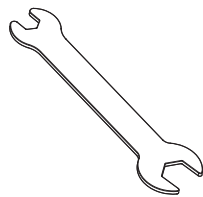

8/10 mm Wrench  
(Included)

## Box Contents:

- Scooter
- Screws
- Owner's Manual
- Philips Screwdriver
- 8/10 mm Wrench

# ASSEMBLY AND SET-UP

## □ Assembling the T-bar

Tool required: 8 mm wrench and Philips Screwdriver.

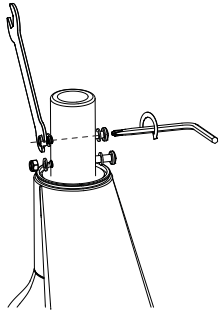

**1** Using the 8 mm wrench and Philips Screwdriver remove screws (x2) from the front fork.

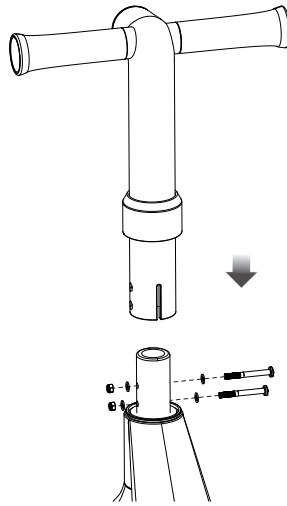

**2** Slide the T-bar on to the front fork.

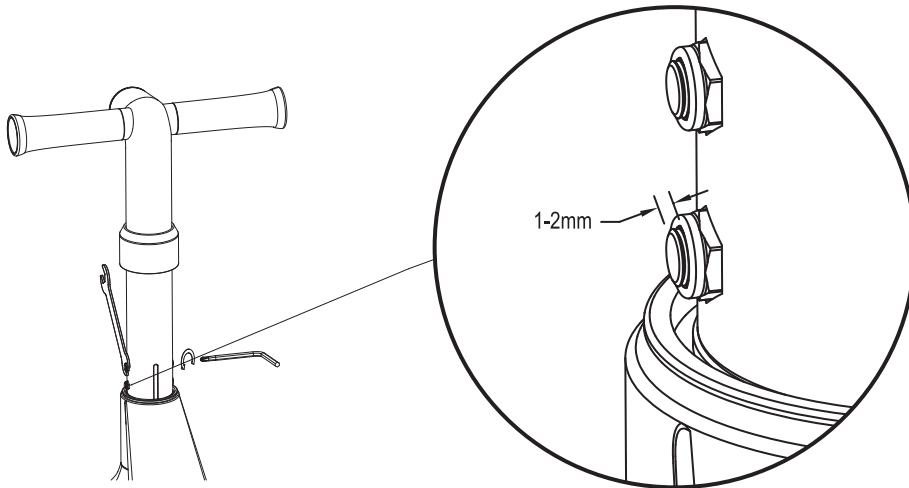

**3** Tighten the bolts. Note: End of bolts should extend beyond nut 1-2 mm after tightening.

**NOTE:** Make sure the Razor logo is facing outward when inserting the T-bar.

**⚠ WARNING:** Failure to properly install and tighten the handlebars and the plastic cover may cause the rider to lose control and fall. If you do not understand these instructions, contact Razor customer care for assistance.

## ASSEMBLY AND SET-UP

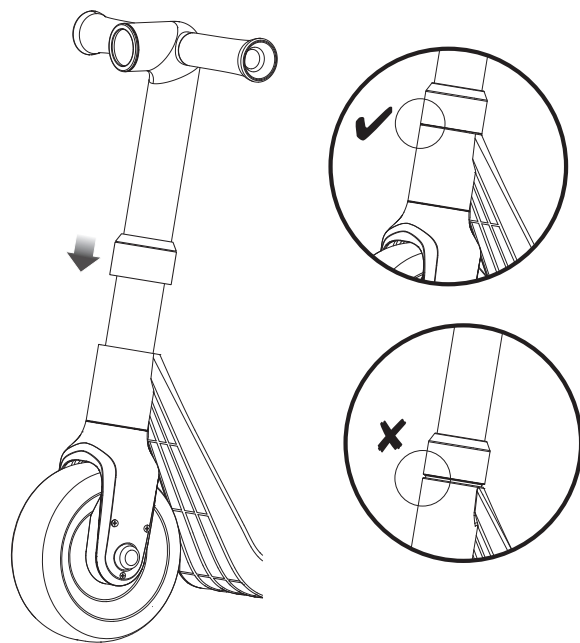

- 4 Slide the T-bar Hardware Cover to cover screws on T-bar, snap into place.



## PRE-RIDE CHECKLIST



### Deck and Handlebars

Check for cracks or broken connections. Although broken decks are rare, it is possible for an aggressive rider to run into a curb or object and wreck and bend or break the deck. Get in the habit of inspecting your scooter on a regular basis.



### Hardware/Loose Parts

Check and secure all fasteners before every ride. Make sure the handlebars and the plastic cover are locked properly in place before riding. There should not be any unusual rattles or sounds from loose parts or broken components. If the unit is damaged, do not ride. Reference "Safety Warnings" on page 1 of this manual.



### Safety Gear

Always wear proper protective gear, such as an approved safety helmet. Elbow pads and kneepads are recommended. Always wear closed toe shoes (lace-up with rubber soles) and keep shoelaces tied and out of the way of the wheels. NEVER RIDE BAREFOOTED OR IN SANDALS.



### Laws and Regulations

Always check and obey any local laws or regulations.



### Be Careful!

This product is not for aggressive or trick riding. Avoid steep inclines and don't ride too fast — you can lose control and fall. Skateboard parks are not designed for young riders. Never ride in traffic or on the street and watch your surroundings for pedestrians, bikers, boarders and skaters.

Maintain a hold on the handlebars at all times.

## USAGE

### How to Ride

With your child standing next to the scooter, have them hold both grips of the handlebar firmly. Test the steering by turning the handlebars right and then left to teach them how the handlebars control the direction of the front wheel.

Have your child place one foot on the deck (where the grip tape is) while keeping the other foot on the ground. The scooter may tilt to one side a little, this is normal.

When stabilized and ready, give the scooter a little push and take a step with the foot that's on the ground. That's it, they're scooting!

### How to Stop

Step off to stop! Wild Ones scooters were developed with your child's age in mind. The scooter is slow rolling and does not require complicated braking mechanisms that detract attention from focused learning. Simply putting one's foot down or dismounting the scooter is enough to come to a complete stop.

### Things to Remember

Remember to help them steer straight when moving in a straight line, this will promote balance. When your child runs out of room to scoot, have them turn around and come back by dismounting the scooter, steering the handlebars while walking to turn it around. They will need your help and guidance as this is a new experience.

## REPAIR AND MAINTENANCE

### Cleaning

Wipe with a damp cloth to remove dirt and dust. Do not use industrial cleaners or solvents, as they may damage the surfaces. Do not use alcohol, alcohol-based or ammonia-based cleaners, as they may damage or dissolve the plastic components or soften the decals or decal adhesive.

### Wheels

Under normal circumstances and conditions, Razor wheels are maintenance free. Nonetheless, it is the responsibility of the owner or guardian to periodically inspect the wheels for wear and tear, the axle for proper tightness, and for loose parts. When a wheel develops play, this is an indication of excess wear and replacement is necessary. Replace immediately with only genuine Razor wheels. Worn wheels are considered normal wear-and-tear and are not covered by the Razor Warranty. Wheels other than genuine Razor wheels may not be compatible with your Razor scooter. The use of anything other than genuine Razor replacement parts may affect your safety and will void your warranty.

# PRODUCT PARTS

Keep your product working for years with genuine Razor parts. Visit our website for more information on spare part availability.  
(Specifications subject to change without notice.)

1. Handlebar w/T-bar

- 1-1 Eye Decal
- 1-2 Nut (x2)
- 1-3 Bolt (x2)

2. Front Wheel Assembly

- 2-1 Front Axle Cap (x2)
- 2-2 Fixed Cap (x2)
- 2-3 Front Wheel Bushing / Spacer (x2)
- 2-4 Front Axle

3. Rear Wheel Assembly

- 3-1 Rear Axle Cap (x2)
- 3-2 Fixed Cap (x2)
- 3-3 Rear Bushing / Spacer (x2)
- 3-4 Rear Axle

