



Spark™ Series Scooters



MANUAL

**Read and understand this entire manual before allowing child to use this product! For assistance contact Razor.
DO NOT RETURN TO STORE.**

**NOTE: Manual illustrations are for demonstration purposes only.
Illustrations may not reflect exact appearance of actual product.
Specifications subject to change without notice.**

CONTENTS

Safety Warnings	1
Before You Begin.....	2
Assembly and Set-up.....	3-4
Pre-Ride Checklist and Usage.....	5

Repair and Maintenance.....	6-7
Spark Scooter Parts List.....	8
Warranty and Contact Information.....	10

SAFETY WARNINGS

⚠ AN IMPORTANT MESSAGE TO PARENTS: This manual contains important information. For your child's safety, it is your responsibility to review this information with your child and make sure that your child understands all warnings, cautions, instructions and safety topics. All children and preteens should ride with adult guidance at all times. Razor USA recommends that you periodically review and reinforce the information in this manual with younger riders, and that you are required to inspect and maintain your child's scooter to ensure their safety. A parent's decision to allow his or her child to ride this product should be based on the child's maturity and ability.

⚠ GENERAL WARNING: Scooter riding can be a hazardous activity. Scooters can and are intended to move and it is therefore possible to get into dangerous situations and/or lose control and/or fall. If such things occur you can be seriously injured or die. LIKE ANY OTHER MOVING PRODUCT, USING A SCOOTER CAN BE A DANGEROUS ACTIVITY AND MAY RESULT IN INJURY OR DEATH EVEN WHEN USED WITH PROPER SAFETY PRECAUTIONS. USE AT YOUR OWN RISK AND USE COMMON SENSE.

- Not for children under 8 YEARS of age. Use only under close adult supervision.
- Do not exceed 143 lb (65 kg) total weight on the Spark™ scooter. Rider weight does not necessarily mean a child's size is appropriate to fit or maintain control of the scooter.
- Adults must assist children in the initial adjustment procedures to unfold scooter, adjust handlebar and steering height, and finally to fold scooter.
- Always wear safety equipment such as a helmet, knee pads, elbow pads and shoes. Always wear a helmet when riding your scooter and keep chinstrap securely buckled.
- Check and secure all fasteners before every ride and replace worn or broken parts immediately.
- For outdoor use only on solid, clean, dry, hardened surfaces. Always ride away from motor vehicles and pedestrians.
- Avoid sharp bumps, drainage grates, and sudden surface changes that may cause your scooter to suddenly stop.
- Avoid streets and surfaces with water, sand, gravel, dirt, leaves and other debris. Wet weather impairs traction, braking and visibility.
- Avoid excessive speed associated with downhill rides.
- Always obey all local traffic and scooter riding laws and regulations.
- Before riding, parents must review all warnings and instructions with each rider.
- Observe all other Spark™ scooter safety warnings and instructions as provided elsewhere in this manual.

⚠ WARNING: SPARKS CAN INDUCE FIRE

To reduce the risk of **SERIOUS INJURY** or **FIRE**:

PARENTS and RIDERS: Make sure riders understand that sparks can start a fire. Keep sparks away from flammable or combustible substances. Use only under close adult supervision.

BE RESPONSIBLE: Safety is important. Parents must review the following warnings and instructions with each rider:

- For outdoor use only on solid, clean, dry hardened surfaces. Keep sparks away from substances that can catch fire, such as dry vegetation, paper, chemicals or gasoline. Sparks can induce fire.
- Do not use in any area prone to wildfires or posted by fire authorities as a Fire Hazard Zone.
- Never use your scooter to try to start a fire. Your Spark™ scooter emits localized sparks when the Spark Bar on a moving scooter comes in contact with hardened outdoor surfaces like asphalt or concrete. Be responsible.
- Do not ride at night or when visibility is impaired.
- Keep sparks away from eyes, hair, exposed skin and clothing. Sparks can burn.
- Spark Bar and brake get hot during use. Do not touch after use.

PROPER RIDING ATTIRE

Always ensure child is wearing proper protective equipment, such as an approved safety helmet. A helmet may be legally required by local law or regulation in your area. A child should always wear shoes and keep shoelaces tied and out of the way of the wheels. Never ride barefooted or in sandals. Knee pads and elbow pads are recommended.

⚠ WARNING: ALWAYS INSPECT SCOOTER PRIOR TO RIDING. Properly inspecting and maintaining your scooter can reduce the risk of injury. Always inspect your scooter before riding and regularly maintain it.

⚠ WARNING: CHECK LOCAL LAWS REGARDING SCOOTER USE. Check local laws and regulations to see where and how you may use your Razor scooter legally. In many states and local areas scooter riders are required BY LAW to wear a helmet. Check local laws and regulations regarding laws governing helmet use and scooter operation in your area, including laws or regulations designating High Fire Hazard areas.

⚠ WARNING: BUTTON/COIN CELL BATTERY (SPARK 2.0 ONLY)

- This product contains a Button or Coin Cell Battery. A swallowed Button or Coin Cell Battery can cause internal chemical burns leading to death in as little as two hours. Dispose of used batteries immediately. Keep new and used batteries away from children. If you think batteries might have been swallowed or placed inside any part of the body, seek immediate medical attention.
- Batteries included for lights - adult attention for changing and disposal.
- Battery should only be replaced by an adult.
- Loose battery could present a choking hazard and should be kept away from small children.
- Dispose of batteries properly.

FAILURE TO USE COMMON SENSE AND HEED THE ABOVE WARNINGS FURTHER INCREASES SUCH RISKS OF SERIOUS INJURY. USE AT YOUR OWN RISK AND WITH APPROPRIATE AND SERIOUS ATTENTION TO SAFE OPERATION. USE CAUTION.

BEFORE YOU BEGIN

Remove contents from box. Remove the packing material used to protect the components from damage during shipping. Inspect the contents of the box for scratches in the paint and dents that may have occurred during shipping. Because your scooter is assembled and packed at the factory, there should not be any problems, even if the box has a few scars or dents.

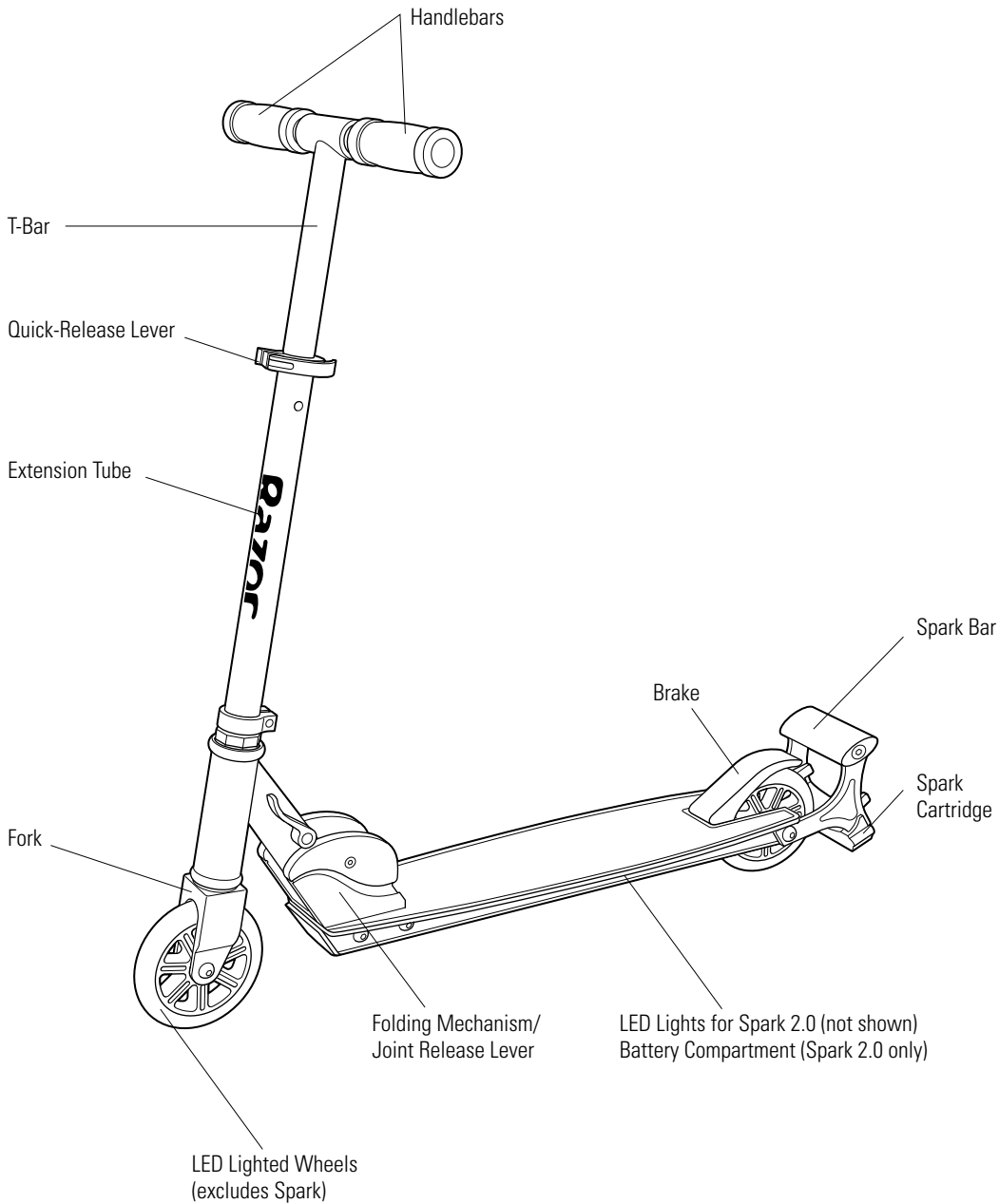

WARNING:

DO NOT USE NON-RAZOR PRODUCTS WITH YOUR SCOOTER. Razor scooters have been built to certain Razor design specifications. The original equipment supplied at the time of sale was selected on the basis of its compatibility with the frame, fork and all other parts. Certain aftermarket products may not be compatible and will void the warranty.

Product ID Locations:

1. Side of deck plate
2. Box - side of UPC (not shown)

Box Contents:

- Scooter
- Two (2) Lithium batteries (Spark 2.0 only)
- Owner's manual

ASSEMBLY AND SET-UP

❑ Folding and Unfolding the Scooter

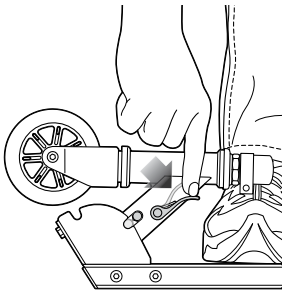

1 To release the folding mechanism, place the scooter on the ground and place one foot on the deck plate. Push the joint release lever **down** (to **raise**) or **up** (to **lower**) the T-bar until it is securely locked in the desired upright or folded position for riding or storage.

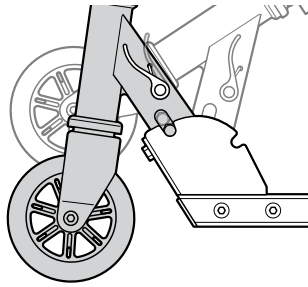

Note: The joint release lever is spring-loaded and will automatically lock in the upright position when fully upright or folded position when fully lowered.

❑ Assembling the Handlebars

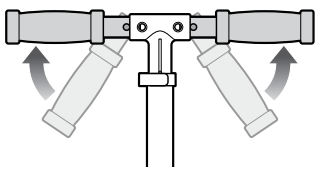

1 Raise handlebars up so they are level with the T-bar.

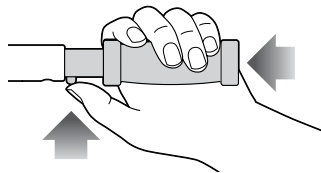

2 Secure the handlebars into the T-bar by depressing the spring-loaded buttons and inserting the handlebars into the T-bar.

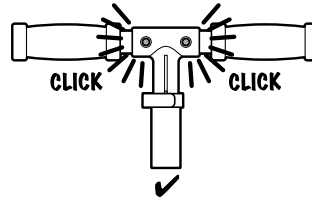

3 Make certain **BOTH** handlebars are properly locked onto the T-bar.

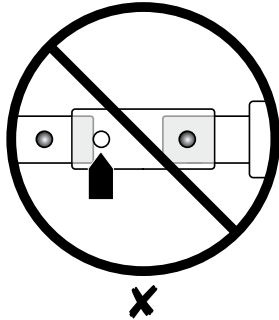
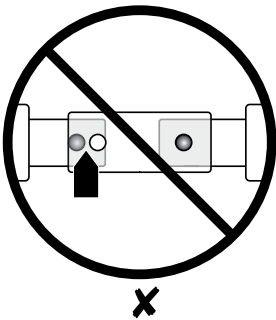

⚠ WARNING:

Keep fingers clear of the folding mechanism when folding or unfolding the scooter. Make sure others are standing clear.

⚠ WARNING:

Failure to properly engage the spring-loaded buttons may cause the handlebars to dislodge while riding and may cause rider to lose control and fall. When correctly engaged, the handlebars will not rotate nor move sideways, and the spring-loaded buttons will be clearly visible in the holes on the T-bar.

⚠ WARNING:

Check handlebar grips and end caps regularly for wear or damage. Grips and end caps are designed to aid in gripping handlebars and to provide some protection against possible impact. Replace immediately if worn, torn, damaged or missing.

ASSEMBLY AND SET-UP

□ Adjusting the Handlebar Height

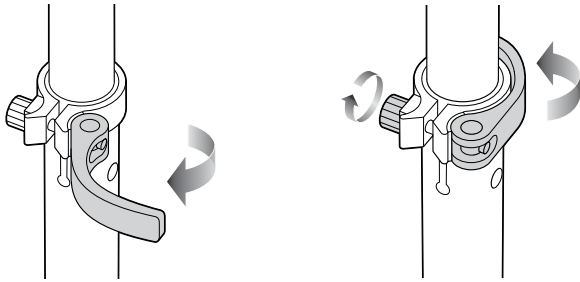

1 To adjust the height of the handlebars, open the quick-release lever and slide the T-bar to the desired position. Close the quick release lever to lock into place. When the T-bar is raised to the maximum height, depress the push button located directly below the quick release lever to unlock the T-bar.

Note: The tension of the quick-release lever can be adjusted by manually tightening or loosening the Allen bolt. Be careful not to over-tighten. You should always be able to open and close the quick-release lever by hand and the T-bar should slide freely when the quick-release is open. Unless T-bar is fully extended.

⚠ WARNING: Failure to properly secure the quick-release lever may cause the T-bar to telescope up or down while riding and may cause you to lose control and fall.

□ Collar Clamp

Tools required: 5 mm Allen wrench

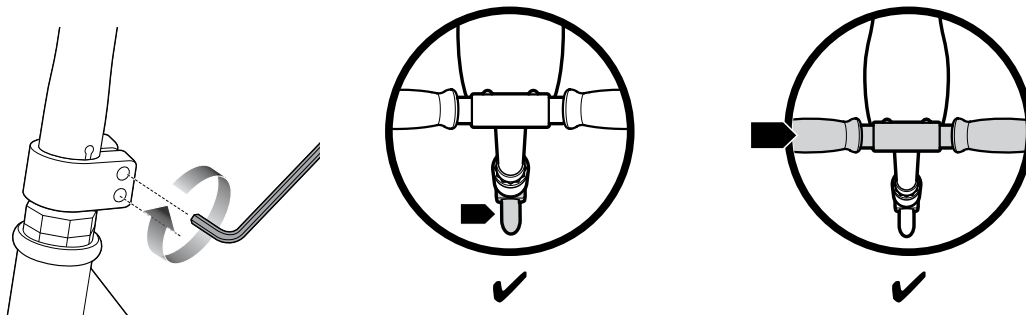

Using a 5 mm Allen wrench, check that the collar clamp bolt(s) are tightened securely. This item is tightened and quality inspected at the factory however there is a slight chance that the effects of shipping or handling may have caused the bolt(s) to loosen.

⚠ WARNING: Failure to properly install and/or tighten the collar clamp may cause the rider to lose control and fall. If you are having difficulty understanding these instructions, please contact Razor Customer Service for assistance.

□ Activating the Batteries (Spark 2.0 only)

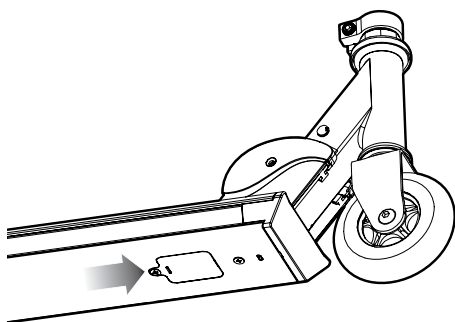

1 To activate the batteries, locate the battery compartment underneath the front of the deck and pull tab out from battery cover.

PRE-RIDE CHECKLIST



Loose Parts

Check and secure all fasteners before every ride. Make sure the collar clamp, quick release lever, and handlebar spring buttons are locked properly in place before riding.



Safety Gear

Always wear proper protective equipment, such as an approved safety helmet, elbow pads and kneepads. Always wear shoes (lace-up with rubber soles) and keep shoelaces tied and out of the way of the wheels. Never ride barefooted or in sandals.



Be Careful!

You will see people on TV and maybe even people you know doing tricks and stunts. These are people who have been practicing on scooters for a very long time. Don't try something until you are ready. Avoid steep inclines and don't ride too fast — you can lose control and fall. Skateboard parks are not designed for scooters. Never ride in traffic or on the street and watch your surroundings for pedestrians, skaters, skate boards, electric products, bikes, children or animals who may enter your path and respect the rights and property of others.

Maintain a hold on the handlebars at all times.

USAGE

How to Ride

Place one foot on the baseboard, push forward with the other foot. Steer with both hands on the handlebars. For enhanced cornering, lean slightly into the direction of the turn.

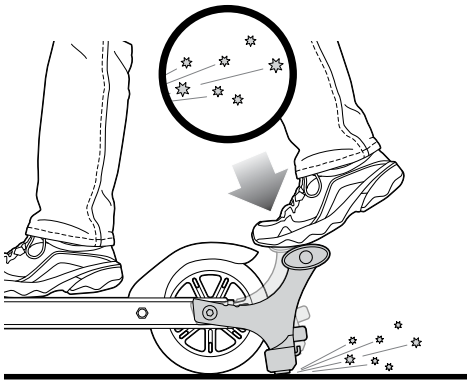

To activate the sparks place ball of foot on the Spark Bar and gradually apply pressure while riding. Only use enough pressure to cause sparking action.

Note:

- LED deck lights apply to Spark 2.0 only.
- Lighted wheels light up when wheels are in motion. (Spark 2.0, Spark DLX, and Spark* only)



WARNING: Applying too much pressure on the Spark Bar may cause loss of control.

NOTE: Using any other part of the foot or full foot may activate the brake and prevent sparking action.

NOTE: Sparks and Spark Cartridge life will vary based on the amount of pressure applied to the Spark Bar, the length of time pressure is applied and the smoothness of the riding surface.

How to Stop

For controlled stops, apply the brake by placing the heel of the foot on the brake. Razor recommends that you practice applying the brake at various speeds and in an open area free from obstructions before riding your Razor scooter around others.

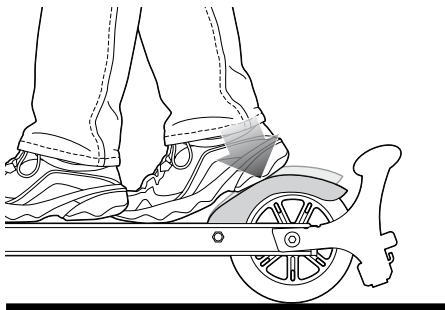

REPAIR AND MAINTENANCE

□ Replacing the Spark Cartridge

Friction during sparking will eventually wear out the replaceable cartridge and cause the scooter to stop making sparks. Worn out cartridges should be replaced to avoid damaging the Spark Bar.

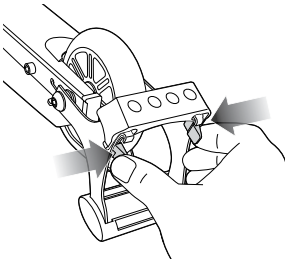

1 Using your thumbs, press tabs on both sides of the cartridge to release from the bracket. Slide cartridge away from you and remove from bracket.

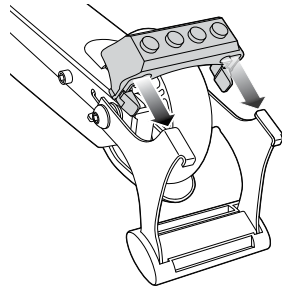

2 Place a new cartridge in back of the bracket making sure to align the slots on the cartridge with the two legs of the bracket. Slide cartridge forward until you hear a click and the thumb tabs are locked in place.

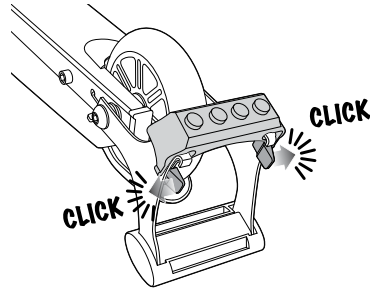

⚠ WARNING: Do not attempt to replace cartridge immediately after riding as cartridge will be hot. Handle only when cool.

⚠ WARNING: Keep fingers clear of Spark Bar hinge and fender brake.

□ Replacing the Batteries (Spark 2.0 only)

Tools required: Phillips screwdriver, Two (2) CR2032 Lithium batteries

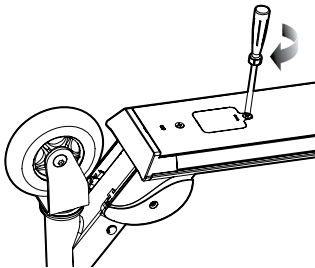

1 Using a Phillips screwdriver, loosen the screw on the battery compartment and remove cover.

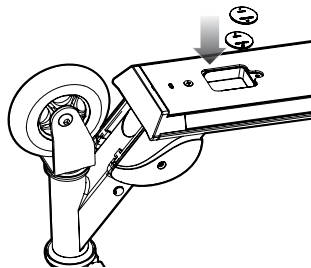

2 Discard old batteries and replace with two (2) CR2032 Lithium batteries.

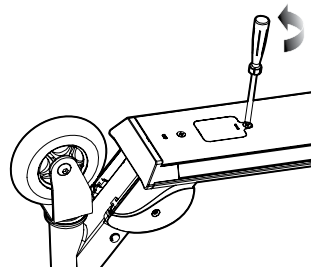

3 Replace cover and secure with screw

Note: Make sure to install **BOTH** batteries positive (+) side up.

⚠ WARNING:

- Lithium batteries included for lights - adult attention for changing and disposal.
- Batteries should only be replaced by an adult.
- Loose batteries could present a choking hazard and should be kept away from small children.
- Dispose of batteries properly.

REPAIR AND MAINTENANCE

Wheels and Bearings

Under normal circumstances and conditions, Razor wheels and wheel bearings are maintenance free. Nonetheless, it is the responsibility of the owner or guardian to periodically inspect the wheels for wear and tear, the axle for proper tightness, and bearings for side-to-side play, and loose parts. When a wheel or wheel bearing develops play, this is an indication of excess wear and replacement is necessary. Replace immediately with only genuine Razor wheels. Worn wheels/bearings are considered normal wear-and-tear and are not covered by the Razor Warranty. Wheels other than genuine Razor wheels may not be compatible with your Razor scooter. The use of anything other than genuine Razor replacement parts may affect your safety and will void your warranty.

Cleaning Your Scooter

Wipe with a damp cloth to remove dirt and dust. Do not use industrial cleaners or solvents as they may damage the surfaces. Do not use alcohol, alcohol-based or ammonia-based cleaners as they may damage or dissolve the plastic components or soften the decals or decal adhesive.

 **WARNING:** Wheelies and other stunt-type riding reduces your ability to maneuver and control your scooter. Take the necessary precautions, such as wearing appropriate protective gear and practice in a area safe for stunt riding and free from obstructions.

SPARK SCOOTER PARTS LIST

Keep your Spark scooter running for years with genuine Razor parts.

- | | |
|--------------------------|--|
| 1. Grips | 9. Axle Bolts |
| 2. Handlebars | 10. Urethane Wheel (Front/Rear)
(Lighted Wheels for Spark DLX, Spark 2.0 and Spark+ only) |
| 3. T-Bar | 11. Folding Mechanism/Joint Release Lever |
| 4. Quick-Release Lever | 12. Spark Bar with Cartridge |
| 5. Extension Tube | 13. Brake |
| 6. Collar Clamp | |
| 7. Headset (Upper/Lower) | |
| 8. Fork | |

