



SERVICE PARTS LIST

BULLETIN NO.
54-49-0300

SPECIFY CATALOG NO. AND SERIAL NO. WHEN ORDERING PARTS		REVISED BULLETIN	DATE
M18™ Radio Charger			Dec. 2013
CATALOG NO.	2792-20	SERIAL NUMBER	F69A
			WIRING INSTRUCTION SEE PAGE 4

Screws behind Left & Right Handles (8x)

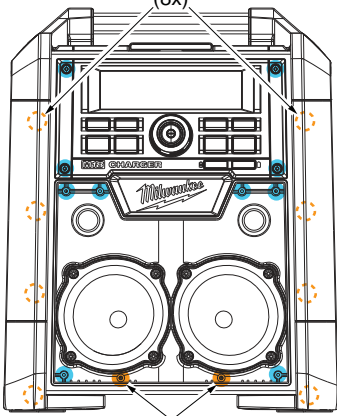

Speaker Grill removed to show these screws

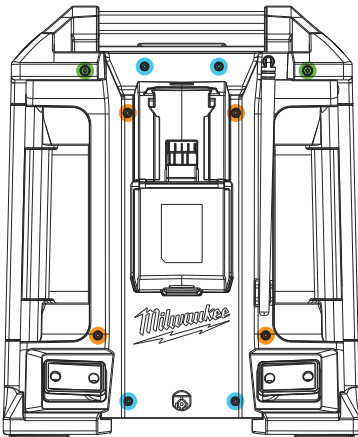

FRONT VIEW

BACK VIEW

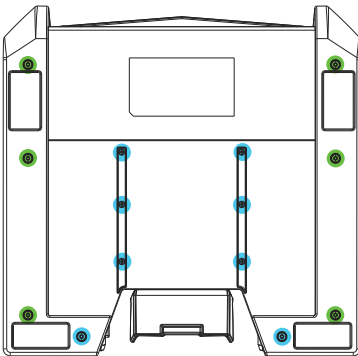

BOTTOM VIEW

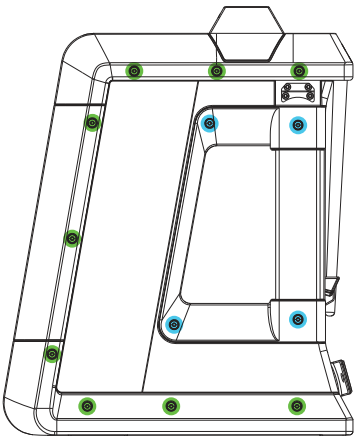

SIDE VIEW

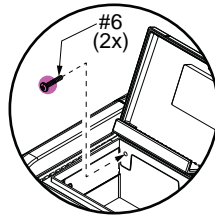

Right Handle

#1 (6x)

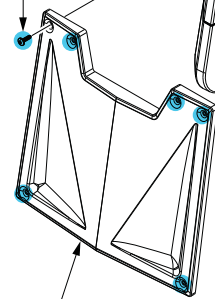

Speaker Grill

NOTE:
All fasteners indicated must be removed to gain access to the interior of the unit and servicing of the Charger and PCBA

NOTE:

The same series of screws that are used for the Left Handle are used on the Right Handle

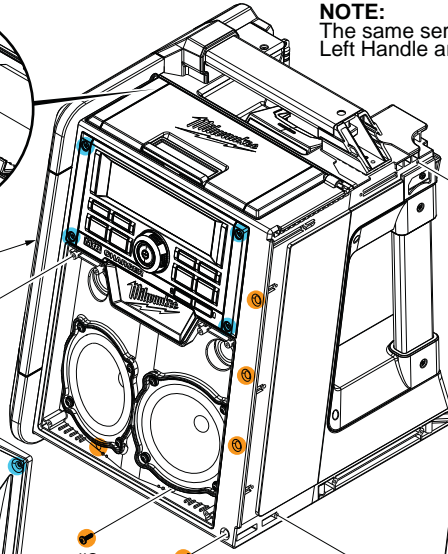

#2 (1x each side) on back of Left and Right Handles

#2 (9x each side) on side of Left and Right Handles

Left Handle

#3 (2x)

#3 (4x each side) Under Left and Right Handles. The Right and Left Handles must be removed to access the eight #3 screws

#1 (1x each side) on bottom of Left and Right Handles

#2 (3x each side) on bottom of Left and Right Handles

Rear Cabinet

Front Cabinet

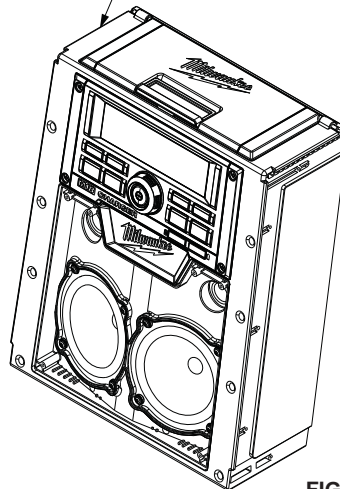

#1 (4x) on the two top and two bottom holes of Rear Cabinet.

#3 (4x) on the Rear Cabinet. See back view detail at the left.

Left Side Handle

#5 (6x) **IMPORTANT:** These 6 screws must be removed from the inside of the Rear Cabinet in order to remove the Left and Right Side Handles.

#1 (4x each side) on side of Left and Right Side Handles
#1 (6x) on the bottom of Rear Cabinet.

FIG.	PART NO.	DESCRIPTION OF PART	NO. REQ.
1	05-88-1735	M3 x 12mm Pan Hd. Hex	(30)
2	05-88-1750	M3 x 16mm Pan Hd. Hex	(20)
3	05-88-1741	M3 x 12mm Pan Hd. Phillips	(14)
5	05-88-1745	M3 x 10mm Pan Hd. Washer Phillips	(6)
6	05-88-1760	M3 x 25mm Pan Hd. Hex	(2)

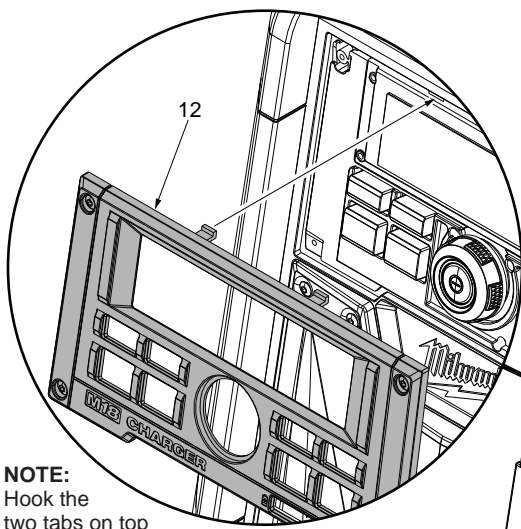

NOTE:
Hook the two tabs on top of Face Plate #12 into the two slots in the Front Cabinet and lower into place. Secure with four screws #1.

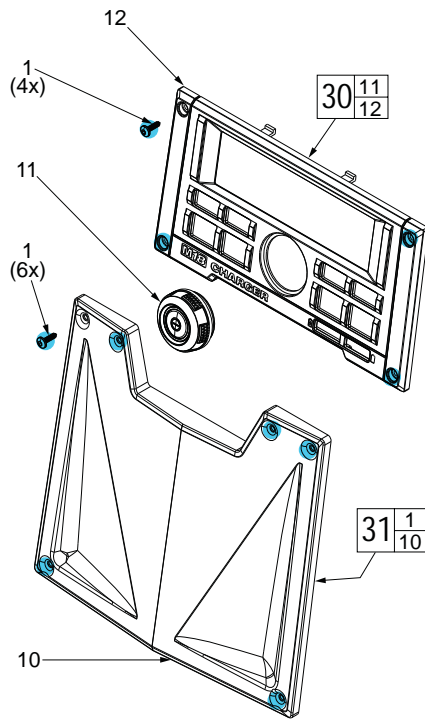

NOTE:
Some of the fasteners shown here are depicted on page one also. You may have removed them already but they are shown in these illustrations for reference purposes.

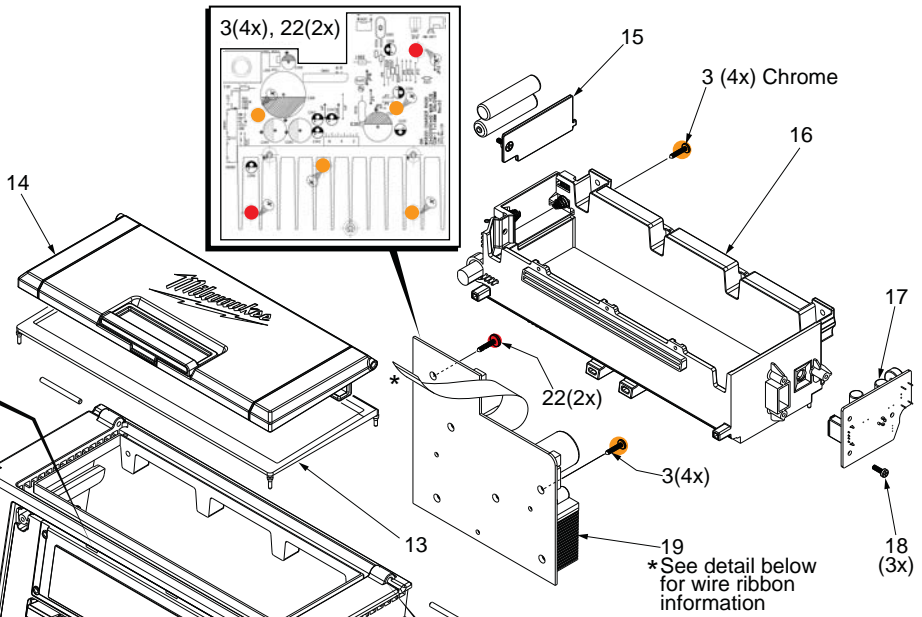

* See detail below for wire ribbon information

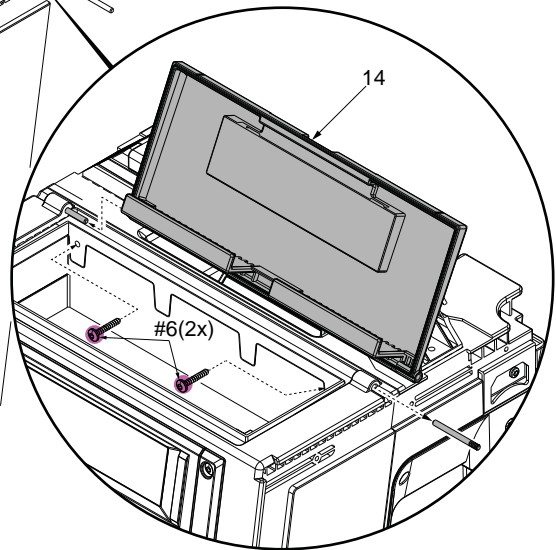

For ease of removal of the device door assembly #14, remove only one of the hinge pins by using a heavy thin wire (like an unbent paper clip) and push the pin outward. If necessary, use a needle nose pliers to grab the knurled end of the pin and remove.



Quantities are for this illustration only (Refer to page one)

FIG.	PART NO.	DESCRIPTION OF PART	NO. REQ.
1	05-88-1735	M3 x 12mm Pan Hd. Hex	(10)
3	05-88-1741	M3 x 12mm Pan Hd. Phillips Screw	(8)
6	05-88-1760	M3 x 25mm Pan Hd. Hex	(2)
10	-----	Speaker Grill	(1)
11	-----	On-Off Dial	(1)
12	-----	Face Plate	(1)
13	45-06-1075	Gasket (Door Seal)	(1)
14	42-92-1700	Device Door Assembly	(1)
15	22-68-0325	Backup Battery Door Assembly	(1)
16	14-06-0150	Device Storage Assy. with AM Antenna	(1)
17	22-09-0035	USB PCBA	(1)
18	05-88-1765	M2.6 x 10mm Pan Hd. Phillips Screw	(3)
19	22-09-0490	Main PCBA	(1)
22	05-88-1770	M3 x 14mm Pan Hd. Washer Phillips	(2)
28	12-20-2792	Service Nameplate	(1)
30	14-46-0875	On-Off Dial with Face Plate	(1)
31	43-40-0730	Speaker Grill with Screws	(1)

FIG. 28 NOTES
A clean, dry surface is essential for proper performance for any adhesive system. The area intended for application of any adhesive label or nameplate must be prepared by cleaning with isopropyl alcohol. The solvent is to be applied with a clean, lint free applicator and the surface allowed to dry before applying the label or nameplate.

IMPORTANT: Care must be taken when installing the wire ribbon into the terminal port of the Main PCBA #19 and the corresponding terminal port on the PCBA for the control panel.

PRIOR TO INSTALLING Main PCBA #19

into the Front Cabinet, carefully line up one end of the wire ribbon in the opening of the terminal port. With a slight side to side rocking motion, work the ribbon into the terminal port cavity until that end is fully seated. Repeat on the other terminal port.

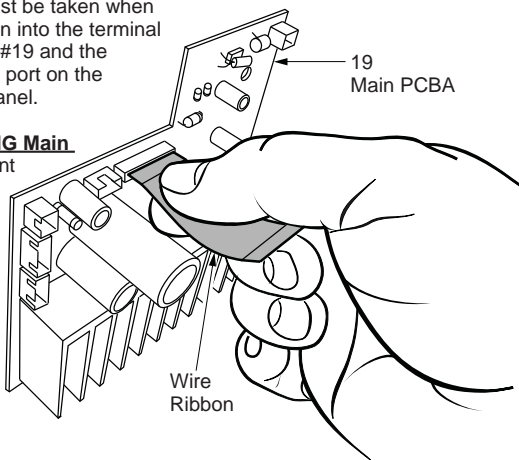

If replacing the USB PCBA #17, wires from that assembly are routed through wire traps on the Device Storage Assy. #16. During the manufacturing process, those traps are melted over to secure leadwires and wire harnesses. To free the wires of the USB PCBA, use a small needle nose pliers or a knife blade to carefully remove the melted material. Secure the new USB PCBA onto the Device Storage Assembly with three screws and route the wires through the same traps. Secure the wires with hot glue.

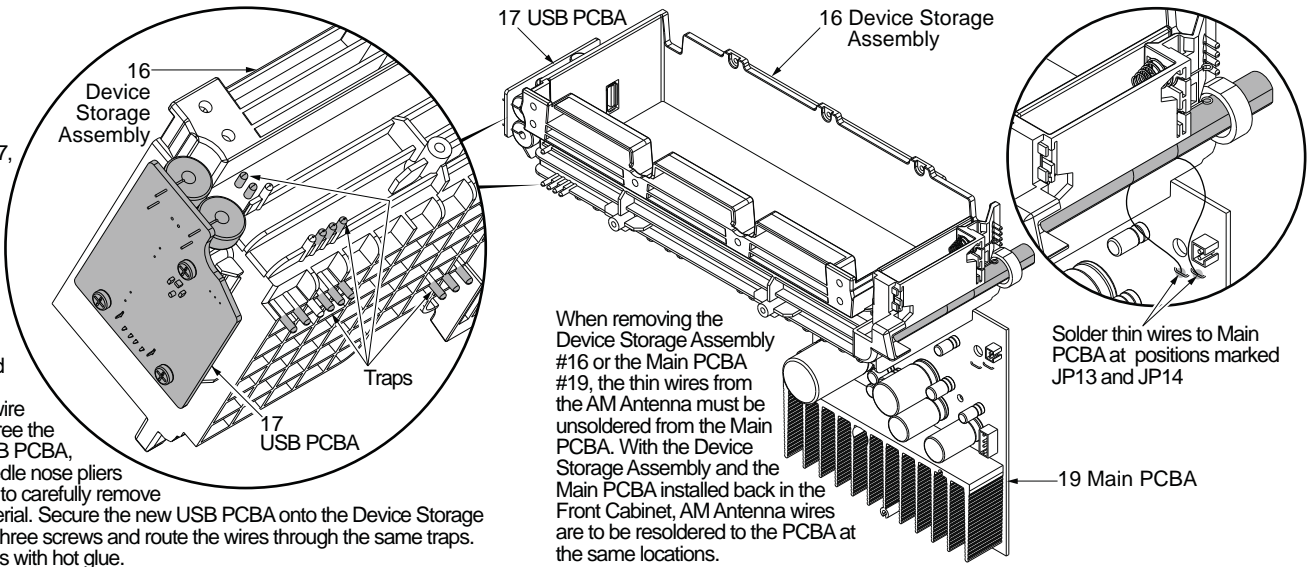

When removing the Device Storage Assembly #16 or the Main PCBA #19, the thin wires from the AM Antenna must be unsoldered from the Main PCBA. With the Device Storage Assembly and the Main PCBA installed back in the Front Cabinet, AM Antenna wires are to be resoldered to the PCBA at the same locations.

Solder thin wires to Main PCBA at positions marked JP13 and JP14

00
0

EXAMPLE:
Component Parts (Small #)
Are Included When Ordering
The Assembly (Large #).

Illustration shown without the top handle for clarity of where screw #25 is located. Top handle does not have to be removed.

NOTE:
Some of the fasteners shown here are depicted on page one also. You may have removed them already but they are shown in these illustrations for reference purposes.

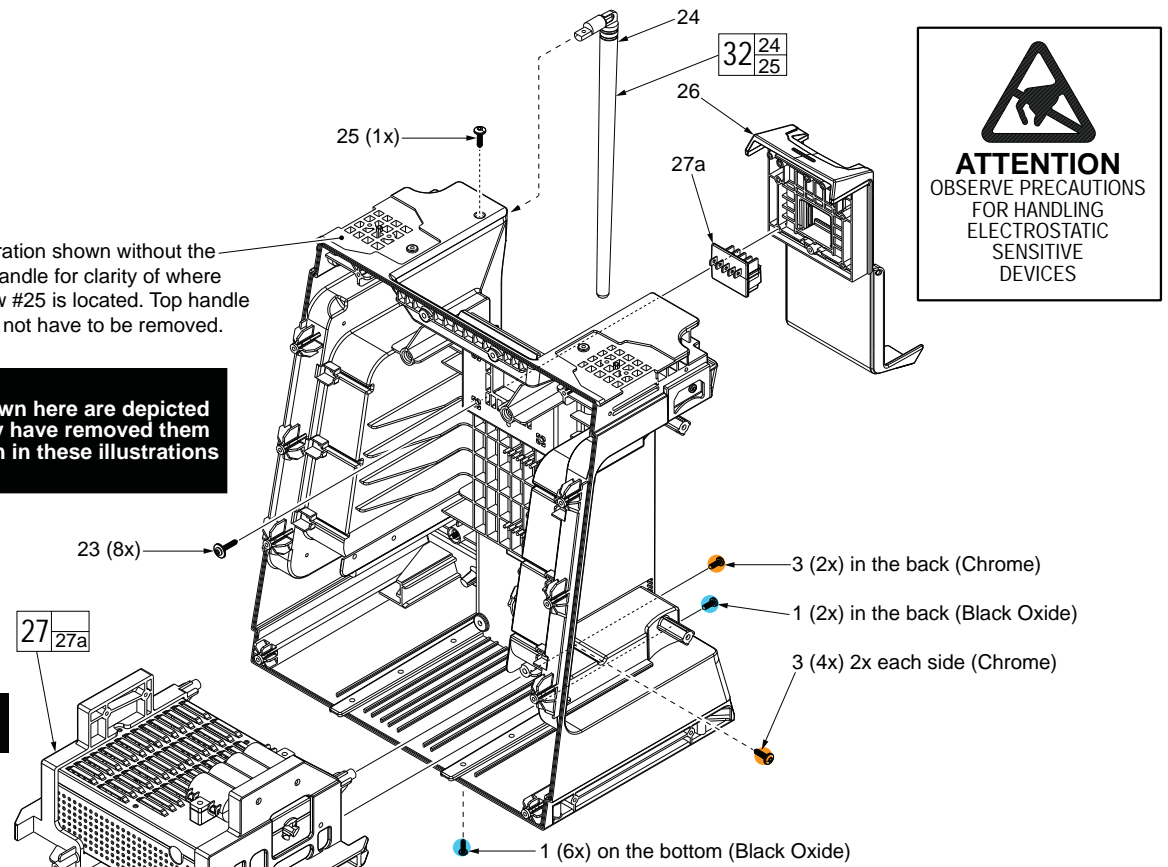

ATTENTION
OBSERVE PRECAUTIONS
FOR HANDLING
ELECTROSTATIC
SENSITIVE
DEVICES

SEE PAGE 4 FOR WIRING INSTRUCTIONS

Quantities are for this illustration only (Refer to page one)

FIG.	PART NO.	DESCRIPTION OF PART	NO. REQ.
1	05-88-1735	M3 x 12mm Pan Hd. Hex	(8)
3	05-88-1741	M3 x 12mm Pan Hd. Phillips	(6)
23	05-88-1775	M3 x 16mm Pan Hd. Washer Phillips	(8)
24	-----	FM Antenna	(1)
25	-----	M3 x 6mm Pan Hd. Hex	(1)
26	31-15-2350	18V Bracket/Door Assembly	(1)
27	14-38-0850	18V Charger Assembly	(1)
27a	-----	Battery Terminal Connector Block	(1)
32	42-09-0500	FM Antenna with Screw	(1)
33	22-64-0985	Cord Set (Not Shown)	(1)
34	42-44-0225	Auxiliary Input Cable (Not Shown)	(1)

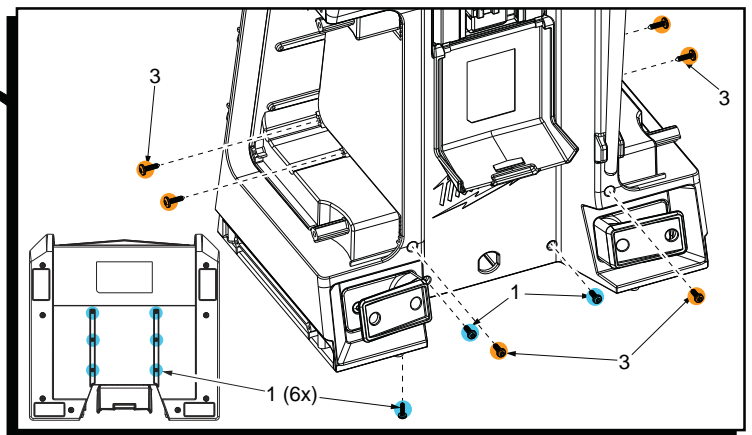

NOTE: With the Front Cabinet separated from the Rear Cabinet, the fasteners that are indicated in this illustration must be removed from the Rear Cabinet in order to take out the Charger Assembly #27.

4 wire harness
(4 white wires)
from Charger
Assembly

Red and black wires
from USB PCBA

Multi-colored
5 wire harness
(black, red, orange,
yellow and blue)
from Charger
Assembly

Multi-colored
4 wire harness
(black, red, black
and yellow)
from
Speakers

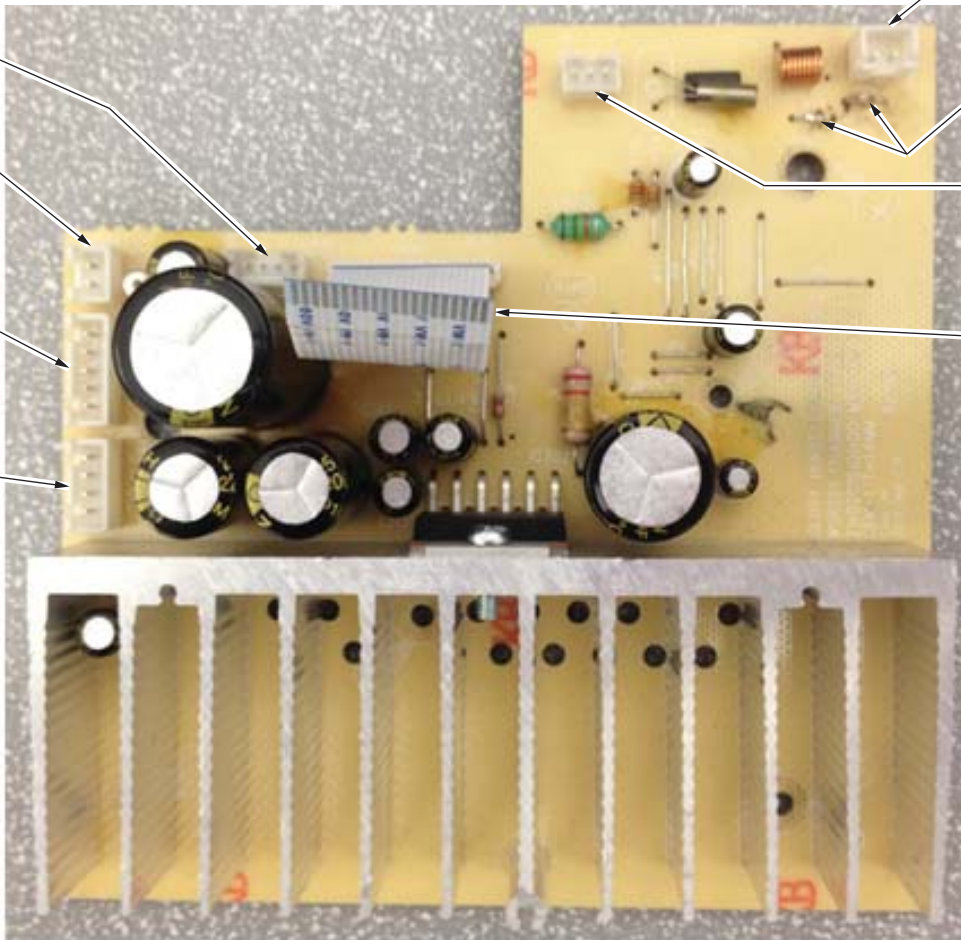

Red wire from FM Antenna

Solder AM Antenna
wires here

Red, black and white wires
(contained in Grey
insulating sleeve)
from the
USB PCBA

Wire Ribbon to Control
Panel PCBA



USB
PCBA

Control Panel
PCBA

Speakers

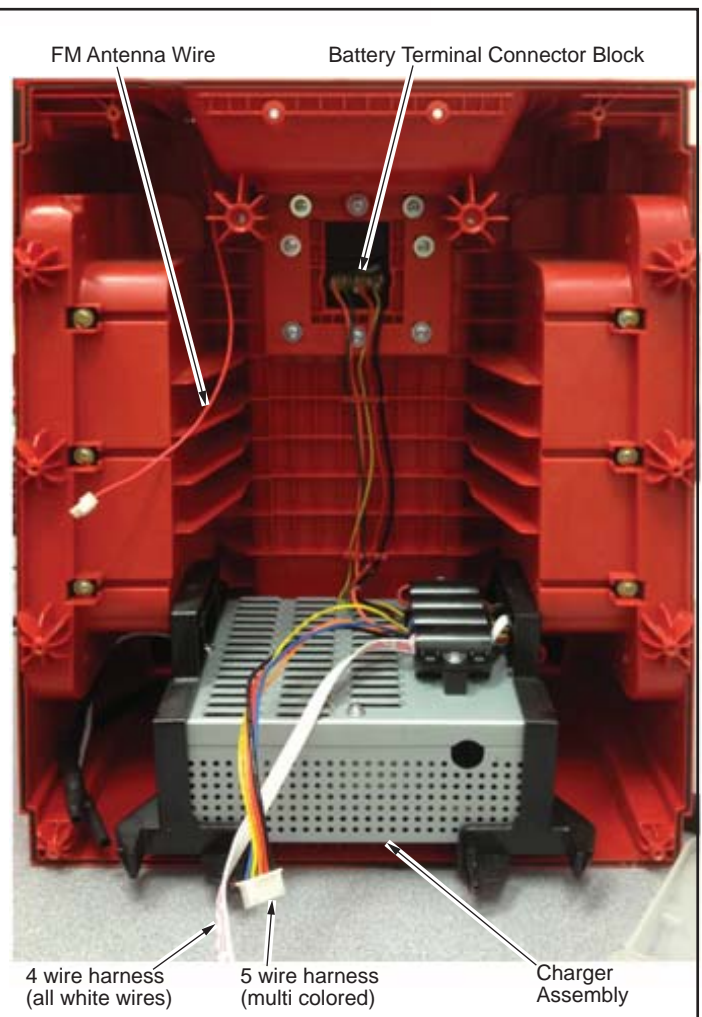

FM Antenna Wire

Battery Terminal Connector Block

4 wire harness
(all white wires)

5 wire harness
(multi colored)

Charger
Assembly