

**PRO
4000
KIT
SHOWN**

**Auto-Drum powder measure
90811**

Die wrench included

Works on spline drive breech lock bushings and lock rings.



(NOT PICTURED)
1/4-20 X 5/16 PHIL. PAN.
FQ1869

TOOL HEAD
PR2050

INDEX ROD
PR3716

CASE RETAINER SCREWS (3)
6-19 X 1/4 PAN HD PLASTITE
FP2111

(NOT PICTURED)
CASE RETAINER O-RING (3)
PR2039

CASE RETAINER
PR3691

BASE
TR3642

PRIMER ARMS

LINK BOLT (qty. 2)
TP2117

LUBRICATION POINT

LUBRICATION POINT

CONNECTING LINK
TP2129

RAM
PR3717

PRIMER OUTLET # TP3707

LUBRICATION POINT

DISPOSAL TUBE # BP3064
CAP # BP3127

SMALL
TP1332

LARGE
TP3796

LEVER CLAMP # OF3613
5/16-18 X 1/4 BOLT
FO2113
1 1/8" WASHER
OF3609

(NOT PICTURED)
LINK NUT (qty. 2)
FB1181

TOGGLE (qty. 2) # OF2853

RAM PIN # OF3221

! DANGER

Ammunition reloading can be dangerous if done improperly and can result in serious injury or death.

! CAUTION

- Reloading should not be attempted by persons not willing and able to read and follow instructions exactly.
- Children should not be permitted to reload ammunition without strict parental supervision.
- Always wear safety glasses and hearing protection when reloading and shooting.
- Ammunition loaded with these tools and data should only be used in modern guns in good condition.
- We do not accept responsibility for ammunition loaded with these tools or data as we have no control over the manufacture and storage of components or the loading procedure and techniques.
- Primers and gun powders, like gasoline and matches, can be dangerous if improperly handled or misused.

Universal Case Feeder

90242

Safety Prime

90997

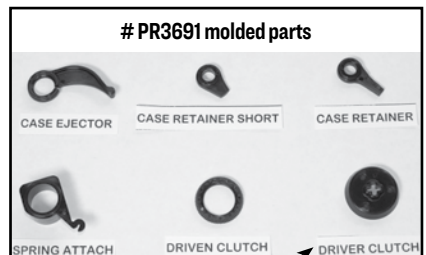
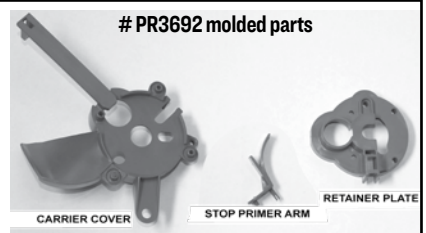

Unable to index? Verify driver clutch is installed.

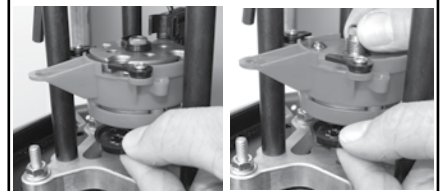

Install driver clutch when no shell plate is installed. Install driver clutch when shell plate is installed.

Bin & Bracket

90687

Spline Drive Breech Lock Bushings

Press includes Spline Drive Breech Lock bushings, leave them in place or order additional for quick change convenience. New, easy grip splined drive surface allows easy, accurate, and fast die installation in your press. Color coded for quick positive identification. Lock rings are not required on your dies when utilizing these bushings.



90063 2-PACK

90042 3-PACK

90095 4-PACK

SAFETY CONSIDERATIONS

- Be sure of proper powder and charge for bullet weight selected.
- Wear safety glasses and hearing protection when reloading or shooting.
- Be extremely careful to avoid a double charge. If in doubt, empty the case and recycle it.
- Do not permit distractions while loading. This is a complex machine that needs your fullest attention.

SMOOTH OPERATING TIPS

- Always move the lever smoothly in complete strokes. An interrupted stroke can cause a jam or double charge.
- Do not force it or you will break something. If it does not feel right, stop and check out the problem.
- Oil ram using STP™ motor oil treatment. Using any oil, lubricate link bolts and ram pin every few thousand rounds.

SETUP TOOLS REQUIRED

- Safety glasses & ear protection
- ½" socket or wrench
- ⅜" hex key (also available as an accessory # 91634)

STEPS 1-6 BELOW ARE COVERED IN QUICK-START GUIDE ATTACHED TO YOUR PRESS

- 1** Mount your press. The most convenient way to mount your press is with our **Lee Bench Plate System # 90251**. This system includes all of the mounting hardware and allows for quick press removal without unbolting from bench. Or, purchase (qty. 3) ¼" bolts and nuts and prepare your workbench for use with this press using the drill template provided on the quick start guide attached to your press

90251 Bench Plate



- 2** Re-position handle, tighten securely with ½" socket or wrench.

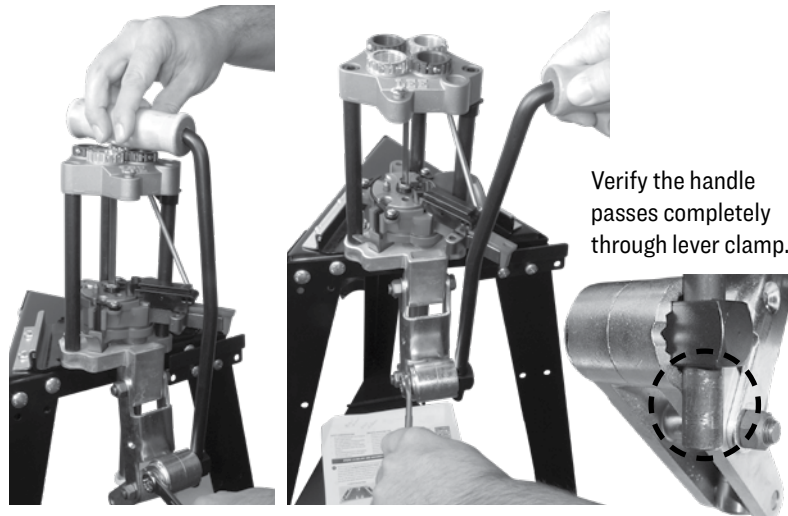

- 3** INSTALL shell plate



Remove Spline Drive breech lock bushing.

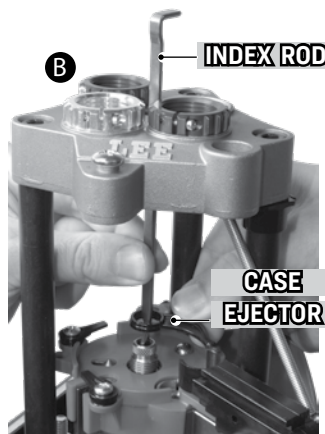

Remove index rod and case ejector.

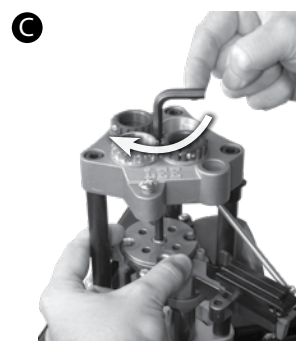

Raise carrier to the mid-stroke position, install shell plate, lightly tighten clockwise with ¼" hex head wrench.



With the carrier at the bottom of the stroke (handle up), install index rod.

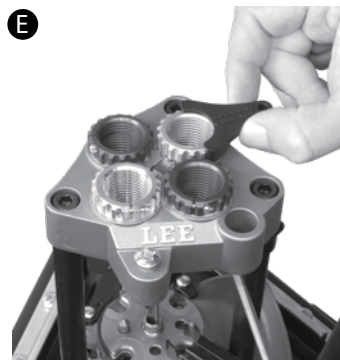

Install Spline Drive breech lock bushing.

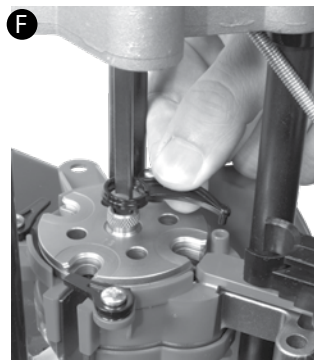

Install case ejector

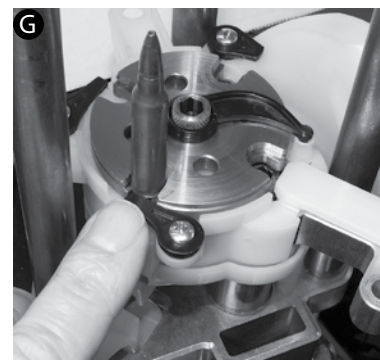

Push case retainer against case rim in each shell plate position

- 4** Raise the retaining ring and slide the primer collection tube assembly into the ram. Slide retaining ring on to assembly.

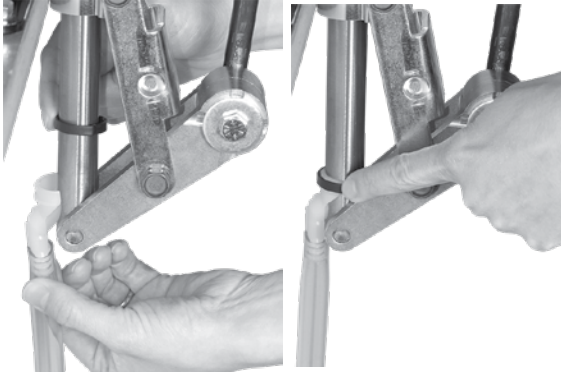

- 5** Install **OPTIONAL** bin and bracket # 90687



Mount to leg of Lee reloading stand using provided 1/4"-20" bolts and 1/4"-20 nuts

OR Mount to workbench using (2) provided # 8 Phillip Head Screws.

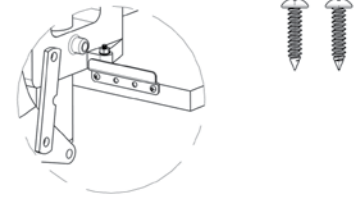
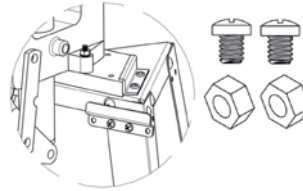

- 6** **INSTALL appropriate primer arm**
Raise ram to mid-stroke position. Install primer arm in the carrier.

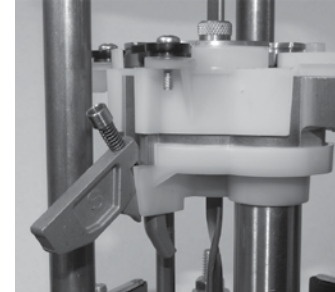
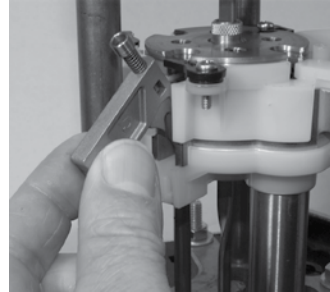
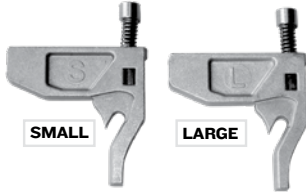

- 7** **TOOL HEAD POSITION & INITIAL SETUP**

The Auto Breech Lock Pro will automatically index with cartridges up to 2.30" (58mm) long. Removing the index rod and manual indexing allows loading most longer action rifle cartridges like the 30/06. Not having the auto index makes the press just as efficient as the popular and expensive Dillon 550™.

Install reloading dies according to the instructions provided with your reloading dies. We suggest Lee dies as they use a powder through expanding die to conveniently charge your brass while expanding the case mouth. Lock rings are not required when utilizing the spline drive breech lock bushing in either station.

Position 2 = Powder Through Expanding Die or Rifle Charging Die

Lower the lever, the case will rise into the powder charging/pistol expanding station to dispense a charge.

Prime

With clean fingers, place the correct size and type of primer into the primer guide. Or dispense primer using the **OPTIONAL**



Lee Safety Prime primer feeder (never touch the primer from box to shell). Raise the lever, seat the primer to flush to slightly below flush

of the case head.

Available accessory # 91634 3/32 hex key

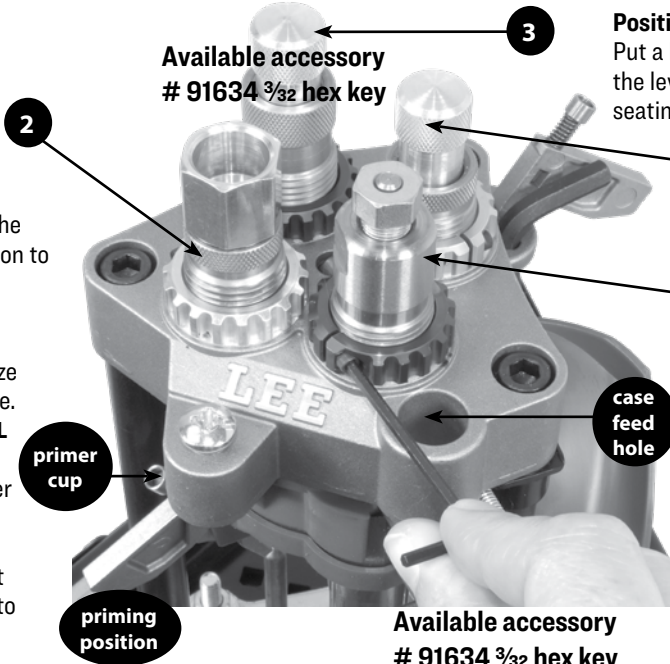

Position 3 = Bullet Seating Die

Put a loose bullet on top of the case mouth. Lower the lever, this will raise the case into the bullet seating/crimping die to seat the bullet.

Position 4 = Factory Crimp Die firmly crimps your bullet in place and will give your round factory like feed and dependability.

Position 1 = Size

IMPORTANT
Verify this die is installed as follows: Remove lock-ring. Screw the die in until it touches the shell plate. Lower the ram, and screw die in 1/3 turn more. Tighten the hex screw on the spline drive bushing with 3/32 hex key. Place a case through the feed hole or the case feeder, and lower the press lever to insert case into the shell plate to be sized. This will punch out the spent primer and size the case back to factory specifications.

Available accessory # 91634 3/32 hex key

If you haven't reloaded before, we suggest you start out using the Auto Breech Lock Pro as the world's most convenient single station press. Simply install your sizing die in position one and you're ready to go. Keep your right hand on the roller handle, cycle the lever to the bottom of the stroke. Pick up a case with your left hand and drop it into the case feed hole next to position one, grab a single primer and place in the primer cup. Raise the lever and the case will be slid into the shell plate and the primer will be seated at the bottom of the stroke (lever up) Lower the lever and the case will enter the sizing die. Drop another case into the case feed hole another primer in the primer cup and repeat the cycle.

You can also operate as you would a Lee turret press and produce a complete round with four cycles of the lever. Install the 3 or 4 dies in the press as shown above. Drop an empty case into the feed hole and cycle the lever four times. A single case will advance through the four stations. You will insert a primer in the priming arm, dispense a powder charge into the powder through expanding die, place a bullet into the flared case and cycle the lever a fourth time to Factory Crimp and automatically eject the finished round.

With a die in every position, you can use the press as a full progressive by simply placing a case in the feed hole every cycle of the lever. Because each station performs one operation, every time you cycle the lever you produce a finished round. If you operate the lever at a leisurely 10 seconds per cycle that is 360 rounds an hour.

8 CARTRIDGE SETUP

To convert the Auto Breech Lock Pro from a one cartridge to another, you will need the proper shell plate and appropriate Lee reloading die set. The chart below shows proper configuration with catalog numbers.

CARTRIDGE	SHELL PLATE	SHELL PLATE PRODUCT #	PRIMER ARM	UNIV. CASE FEED PLATE SIZE	UNIV. CASE FEED SLIDER BLOCK	RELOADING DIES	CHARGING DIE
30 LUGER	19	90944	SMALL	SMALL		90754	
30 MAUSER	19	90944	SMALL	SMALL		90755	
7.62 TOKAREV	19	90944	SMALL	SMALL		90769	
32 ACP	7	90647	SMALL	SMALL		90622	
32 S&W	4	90630	SMALL	SMALL		90696	
32 S&W LONG	4	90630	SMALL	SMALL		90624	
32 H&R MAG / 327 FED	4	90630	SMALL	SMALL		90809	
9MM LUGER	19	90944	SMALL	SMALL		90332	
9MM MAKAROV	19	90944	SMALL	SMALL		90176	
357 SIG	19	90944	SMALL	SMALL		90270	
38 SUPER	19	90944	SMALL	SMALL		90623	
38 S&W	1	90582	SMALL	SMALL		90569	
38 COLT NP	1	90582	SMALL	SMALL		90569	
380 AUTO	4	90630	SMALL	SMALL		90092	
38 SPL & 357 MAG	1	90582	SMALL	SMALL	RISER	90615	
38 ACP	19	90944	SMALL	SMALL		90623	
38 SHORT/LONG COLT	1	90582	SMALL	SMALL		90276	
40 S&W	19	90944	SMALL	SMALL		90571	
10MM AUTO	19	90944	LARGE	SMALL		90566	
41 MAG	9	90278	LARGE	LARGE	RISER	90628	
44 SPL & 44 MAG	11	90648	LARGE	LARGE	RISER	90604	
400 COR BON	2	90584	LARGE	LARGE		90430	
30M1 CARBINE	7	90647	SMALL	SMALL	RISER	90626	
44 RUSSIAN	11	90648	LARGE	LARGE	RISER	90293	
454 CASULL	11	90648	SMALL	LARGE	RISER	90795	
45 ACP	2	90584	SMALL OR LARGE	LARGE		90233	
45 COLT	11	90648	LARGE	LARGE	RISER	90265	
45 GAP	2	90584	LARGE	LARGE		90498	
460 S&W	14	90802	LARGE	LARGE	RISER	90344	
50 ACTION EXPRESS	11	90648	LARGE	N/A	N/A	90329 (LUBE REQ.)	
223 REM	4	90630	SMALL	SMALL	RISER	90253 (LUBE REQ.)	90668
222 REM	4	90630	SMALL	SMALL	RISER	90501 (LUBE REQ.)	90668
458 SOCOM	2	90584	LARGE	N/A	N/A	90409 (LUBE REQ.)	90668
6.8 REM SPC	21	90941	LARGE	SMALL	RISER	90427 (LUBE REQ.)	90668



N/A = Not available LUBE REQ. = # 90006 LEE resizing lubricant required

Feed plate setup for Universal Case Feeder, accessory sold separately # 90242

Assembled as a **SMALL** feed plate



Assembled as a **LARGE** feed plate



INSTALLING Universal Case Feeder, accessory sold separately # 90242



This accessory will greatly simplify progressive reloading placing a case every time the press is cycled. The case slider block is already on your press. Longer cases will require you to attach the riser to the case slider block. All you need to do is install the feed plate configured for the case that you will be loading.

- A** See chart on page 4. Some cases require riser to be installed on top of case slider block. **B** See chart on page 4. Install the correctly configured feed plate (large or small) keeping the bottom of the case feed plate a pennies thickness above the case mouth. Slide a case through feed plate. Place penny on top of the case, slide feed plate into carrier.



A penny's thickness above case mouth

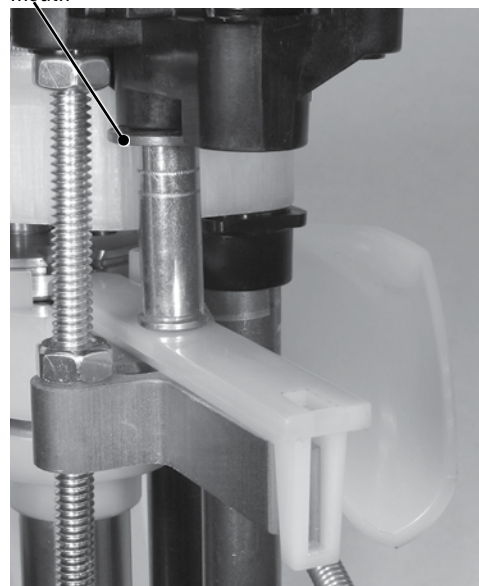

- C** The 4 tube feed plate should be a penny's thickness away from the tool head casting. Verify a coins thickness away from body.

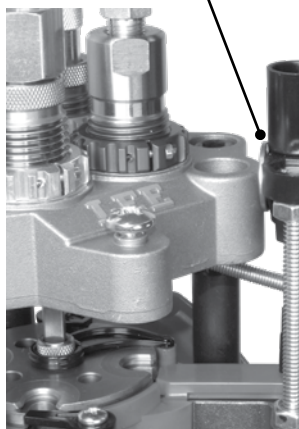

- D** Secure the feed plate with a nut above and below the carrier slide rail. Tighten 7/16" nuts under and above carrier.

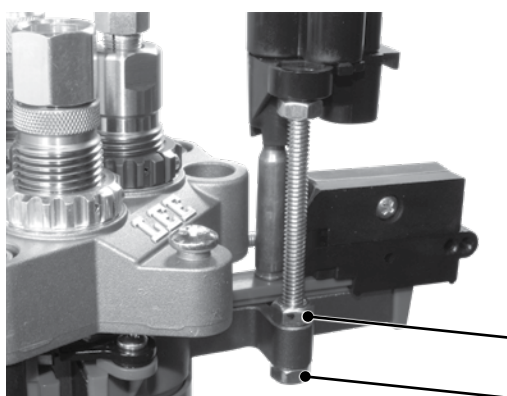

Consider the case collator product # 90667 fill all four case feed tubes in as little as 10 seconds.



Case Collator #90667

INSTALLING Safety Prime, accessory sold separately # 90997



Safety Prime #90997

Dispenses primers with a push of the button. Works with all brands of primers and you never have to handle the tiny primers. Fill the tray in seconds rather than filling a tube one at a time like other brands.

- A** Install the triangular shaped bracket as shown. Rotate the bracket left to right to best align the trigger and trough with the primer arm.

- B** With the carrier at the top of the stroke (lever down) swing the primer trough into the primer arm and push the trigger. Be sure you install the correct primer arm (large or small) and that you have selected the correct trigger assembly (large or small)

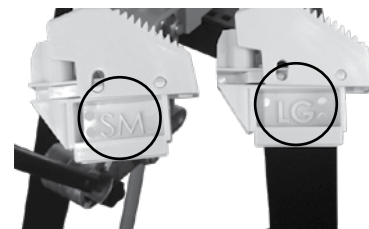
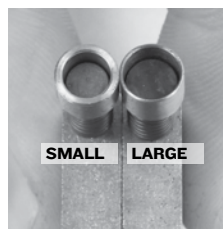

IMPORTANT
Only use the Safety Prime manufactured after June 2017. This version can be identified by the light gray color and serrated trigger.



INSTALLING Automatic Powder Dispenser accessory



Auto-Drum Powder Measure
90811

Pro Auto-Disk Powder Measure
90429

For volume reloading, nothing beats a Lee Auto-Drum or Pro Auto-Disk or powder measure. Either of these automatic powder measures will dispense a powder charge through the Lee powder through expanding die. They are automatic and will only dispense a powder charge if they are activated by a case.

- A** If you are using the pull back feature on the Auto-disk, the chain is installed through this lug.

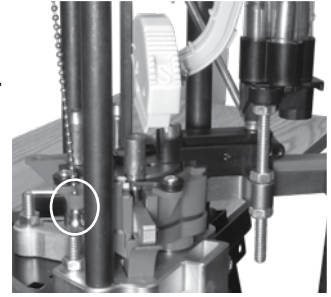

INSTALLING Automatic Bullet Feeder accessory

RECOMMENDED FOR ADVANCED USERS ONLY. Incorrect use will be a frustrating experience.

LEE BULLET FEEDER OPTIONAL

Automatically feeds bullets into the mouth of the seating die. Aligns bullets more accurately than possible by hand. Increases cyclic rate 50 to 100%.



30 & 32 cal. Bullets up to .60 long	# 90892
9mm through .365 diameter up to .46 long	# 90893
9mm through .365 diameter .46 to .60 long	# 90894
9mm through .365 diameter .60 to .75 long	# 90895
40 cal. through .44 cal. up to .65 long	# 90896
40 cal through .44 cal .65 to .80 long	# 90897
45 cal. bullets .50 to .67 long	# 90898

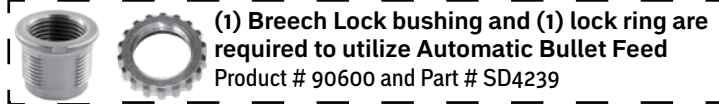

- A** Unscrew 10-24 NUT, remove and discard attach plate # BF3418 from bullet feeder assembly. **HINT:** if finger loosening is uncomfortable, lightly snug with $\frac{3}{8}$ " wrenches.

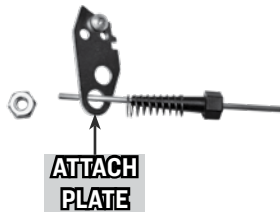

- B** Install friction actuator and spring into carrier cover. Screw 10-24 hex nut on action rod (fits tightly). Finger tighten 10-24 hex nut. **HINT:** if finger tightening is uncomfortable, lightly snug with $\frac{3}{8}$ " wrenches.

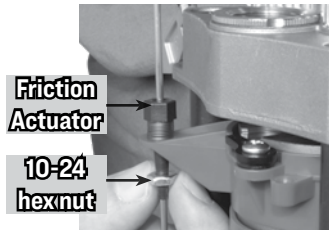

- C** Install Breech Lock bushing into position 3.

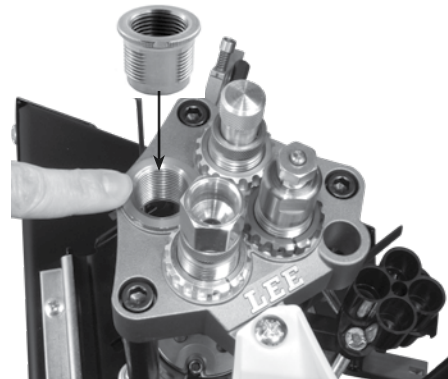

- D** Install action rod into feeder link. Use end hole as shown.



- E** Install bullet seating die with lock ring on and feeder assembly into position 3.

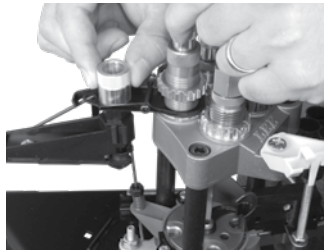

- F** Bullet feed completed installation.

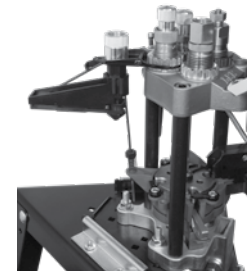

WARNING: Handling live primers and spent primers may expose you to lead or other chemicals, which are known to the State of California to cause reproductive harm and cancer.



WARNING: This product may contain steel alloyed with trace amounts of lead and other elements which are known to the State of California to cause reproductive harm and cancer. To prevent exposure, do not alter the product by welding, grinding, etc.