

# 4GRS

Frequency Hopping Spread Spectrum



Telemetry System



# INSTRUCTION MANUAL

1M23N29602

**Futaba**®

Digital Proportional R/C System



**For Your Safety As Well As That Of Others.....8**

Explanation Of Symbols .....	8
2.4GHz System Precautions.....	8
Receiver Mode Precautions .....	8
Operation Precautions.....	9
NiMH/NiCd Battery Handling Precautions .....	10
Storage And Disposal Precautions .....	10
Other Precautions .....	11

**Before Using .....12**

Features .....	12
Set Contents .....	14
<b>Transmitter T4GRS .....</b>	<b>15</b>
Nomenclature.....	15
Battery Replacement Method.....	16
When Using The Optional Battery.....	17
When Charging The Optional Battery .....	18
Low Battery Alarm.....	19
Power & Display Switch.....	20
Display When Power Switch Is Turned On .....	21
Stick Operation CH1 CH2 .....	22
Switch Dial Operation CH3 CH4 .....	23
Digital Trim Operation.....	24
Stick Lever Head Adjustment .....	25
Stick Mounting Angle Adjustment.....	25
Stick Tension Adjustment .....	26
Mechanical Throttle Stick Stroke Adjustment .....	27
Neutral Adjuster Operation.....	28
Changing to Ratchet Type Throttle Stick .....	30
<b>About Transmitter Antenna And Receiver.....</b>	<b>31</b>
About The Transmitter Antenna.....	31
Receiver Terminology.....	32
Receiver Installation.....	32

**Installation .....33**

Receiver and Servo Connections .....	33
Installation Safety Precautions .....	34

**Initial Set-Up .....37**

**Preparations (Transmitter).....37**

- Receiver Type Check (RX MODE) .....37
- Receiver Type Change & **How To Link** .....38
- Throttle Mode Check.....41
- Trims Initial Set-Up.....41

**For Your Safety  
As Well As  
That Of Others**

**Function Map .....43**

**Operation Of Screen .....43**

- Selecting the Menu Screen .....43
- Selecting Items On The Menu Screen .....44
- Value Of Each Function And Changing The Set Value .....44
- Basic Menu Japanese Katakana Character Display .....45

**Before  
Using**

**Function List.....46**

**Installation**

**Functions .....47**

**Model "MODEL".....47**

- Model Menu Display .....47
- Model Selection "SELECT" .....48
  - Model memory select
- Model Copy "COPY" .....49
  - Model memory copy
- Model Reset "RESET" .....50
  - Model memory reset

**Initial  
Set-Up**

**Model Name "MDL NAME" .....51**

- Model memory name & User name, set/modify

**Function  
Map**

**Servo Reverse "REVERSE" .....52**

- Servo operation reversing

**Functions**

**Sub trim "SUBTRIM" .....53**

- Servo center position fine adjustment

**End Point Adjuster "END POINT" .....54**

- End point adjustment

**Reference**

**Fail Safe Function "FAIL SAFE" .....57**

- Fail safe, battery fail safe function

**Exponential Adjustment "EXP".....59**

- Steering operation curve / Throttle curve adjustment

**Servo Speed "SPEED" .....62**

- Steering/ Throttle servo delay adjustment

**Throttle Acceleration "TH ACCEL" .....65**

- Function which adjusts the initial response from the throttle neutral position

**A.B.S. Function "TH A.B.S" .....67**

- Pulse brake

<b>Channel 3/4 "CH3/CH4"</b> .....	<b>71</b>
Channel 3/4 Position	
<b>Steering Dual Rate/Throttle ATL "D/R ATL"</b> .....	<b>72</b>
Steering D/R, Throttle ATL Rate	
<b>Select Switch Dial Function "SW/ DIAL"</b> .....	<b>73</b>
Selection of functions operated by dial, digital trim and switch	
<b>Brake Mixing "BRAKE MIX"</b> .....	<b>76</b>
Front and rear independent brake control for 1/5GP car, etc.	
<b>Programmable Mixing "PROG MIX"</b> .....	<b>78</b>
Programmable mixing between specific channels	
<b>4WS Mixing "4WS"</b> .....	<b>80</b>
Special mixing used with Crawler and other 4WS type vehicles	
<b>Dual ESC Mixing "DUAL ESC"</b> .....	<b>82</b>
Special mixing used with Crawler and other 4WD type vehicles	
<b>Gyro Mixing "GYRO MIX"</b> .....	<b>84</b>
Used to set the Futaba car rate gyro.	
<b>CPS Mixing "CPS MIX"</b> .....	<b>86</b>
Controls the Futaba CPS-1 channel power switch.	
<b>Throttle Mode "TH MODE"</b> .....	<b>88</b>
Throttle Servo Neutral Position "SXNT" .....	88
Throttle servo forward and brake operation proportion setting	
Idle-Up "IDLUP" .....	89
Idle up at engine start	
Neutral Brake "NTBRK" .....	90
Neutral brake function	
Throttle Off (Engine Cut) "THOFF" .....	91
Engine cut off by switch	
<b>ESC Link Function "MC LINK"</b> .....	<b>92</b>
Special function, Futaba ESC (MC940CR, MC960CR, MC950CR, MC851C, MC602C, MC402CR, etc.)	
<b>Data Transfer "MDL TRANS"</b> .....	<b>100</b>
The T4GRS model memory data to another T4GRS	
<b>Timer Function "TIMER"</b> .....	<b>102</b>
Up, Fuel down, or lap timer	
<b>Lap List "LAP LIST"</b> .....	<b>108</b>
Lap timer data check	
<b>System Functions "SYSTEM"</b> .....	<b>109</b>
Liquid crystal screen contrast adjustment	
Liquid crystal screen backlighting display mode setup	
Backlight display time setup	
Backlight brightness setup	
Battery type setting	
Buzzer sound tone adjustment	

Alarm Setting if Tx is left switched ON  
 Item which displays the basic menu screen in katakana characters for Japanese use  
 Throttle stick adjustment  
 HOME screen display mode setting

**Adjuster "ADJUSTER" ..... 113**

Steering wheel and throttle trigger correction

**Telemetry "TELEMETRY" ..... 115**

Telemetry/ Log Screen Map ..... 116

Telemetry Function ON/OFF ..... 117

Telemetry Sensor Setting ..... 118

Log Setting, Start/ Stop ..... 120

Log Data List ..... 122

**Reference ..... 123**

**Ratings ..... 123**

**Warning Displays ..... 124**

**Optional Parts ..... 126**

**When requesting repair ..... 126**

**For Your Safety  
As Well As  
That Of Others**

**Before  
Using**

**Installation**

**Initial  
Set-Up**

**Function  
Map**



**Functions**

**Reference**

Use this product in a safe manner. Please observe the following safety precautions at all times.

## Explanation Of Symbols

The parts of this manual indicated by the following symbols are extremely important and must be observed.

Symbols	Explanation
 <b>Danger</b>	Indicates a procedure which could lead to a dangerous situation and may cause death or serious injury if ignored and not performed properly.
 <b>Warning</b>	Indicates procedures which may lead to dangerous situations and could cause death or serious injury as well as superficial injury and physical damage.
 <b>Caution</b>	Indicates procedures that may not cause serious injury, but could lead to physical damage.

Symbols:

 : Prohibited

 : Mandatory

## 2.4GHz System Precautions

### **Warning**

 Special attention should be paid before turning on the system while other cars are running or other airplanes are flying because the 2.4GHz RC system could potentially affect them.

 Be sure to set the Fail Safe function.

## Receiver Mode Precautions

### **Caution**

 When using the T4GRS in the T-FHSS (HIGH) and S-FHSS (HIGH) mode, always use it under the following conditions:

**Servos** :Futaba digital servo (including BLS Series brushless servos)

**Receiver's battery** :Matched to the ratings of the receiver and connected digital servo (dry cell battery cannot be used).

**Transmitter mode** :RX MODE

Under other conditions, the set will not operate, or the specified performance will not be displayed even if it operates. In addition, it may cause servo trouble. Futaba will not be responsible for damage, etc. caused by combination with the products of other companies.

In addition, the FSU Fail Safe Unit cannot be used because the system is different. Use the fail safe function of the transmitter.

 When using analog servos, always switch the T4GRS servo response to the "NORM" mode.

**Transmitter mode:**"T-FHSS(NORM)", "T-FHSS(NORM)"and FHSS mode









**Receiver's battery** :Matched to the ratings of the receiver and connected servo (dry cell battery cannot be used).

The set cannot operate in the "HIGH" mode. Operation in this mode will cause trouble with the servo and other equipment.

Digital servos (including BLS Series brushless servos) can also be used in the "NORM" mode.

# Operation Precautions

## Warning

-  Do not operate outdoors on rainy days, run through puddles of water or use when visibility is limited.
- 
- Should any type of moisture (water or snow) enter any component of the system, erratic operation and loss of control may occur.
-  Do not operate in the following places.
- Near other sites where other radio control activity may occur.
  - Near people or roads.
  - On any pond when passenger boats are present.
  - Near high tension power lines or communication broadcasting antennas.
- 
- Interference could cause loss of control. Improper installation of your Radio Control System in your model could result in serious injury.
-  Do not operate this R/C system when you are tired, not feeling well or under the influence of alcohol or drugs.
- 
- Your judgment is impaired and could result in a dangerous situation that may cause serious injury to yourself as well as others.
-  Do not touch the engine, motor, speed control or any part of the model that will generate heat while the model is operating or immediately after its use.
- 
- These parts may be very hot and can cause serious burns.
-  **Always perform an operating range check prior to use.**
- 
- Problems with the radio control system as well as improper installation in a model could cause loss of control.  
(Simple range test method)
- Have a friend hold the model, or clamp it down or place it where the sticks or prop cannot come in contact with any object. Walk away and check to see if the servos follow the movement of the controls on the transmitter. Should you notice any abnormal operation, do not operate the model. Also check to be sure the model memory matches the model in use.
-  **Turning on the power switches.**  
Always check the throttle stick on the transmitter to be sure it is at the neutral position.
1. Turn on the transmitter power switch.
  2. Turn on the receiver or speed control power switch.
- Turning off the power switches  
Always be sure the engine is not running or the motor is stopped.
1. Turn off the receiver or speed control power switch.
  2. Then turn off the transmitter power switch.
- 
- If the power switches are turned off in the opposite order, the model may unexpectedly run out of control and cause a very dangerous situation.
-  **When making adjustments to the model, do so with the engine not running or the motor disconnected.**
- 
- You may unexpectedly lose control and create a dangerous situation.
-  **Before running (cruising), check the fail safe function.**
- 
- Check Method; Before starting the engine, check the fail safe function as follows:
- 1) Turn on the transmitter and receiver power switches.
  - 2) Wait at least one minute, then turn off the transmitter power switch. (The transmitter automatically transfers the fail safe data to the receiver every minute.)
  - 3) Check if the fail safe function moves the servos to the preset position when reception fails.
- The fail safe function is a safety feature that minimizes set damage by moving the servos to a preset position when reception fails. However, if set to a dangerous position, it has the opposite effect. When the reverse function was used to change the operating direction of a servo, the fail safe function must be reset.  
Setting example: Throttle idle or brake position

# NiMH / NiCd / LiFe Battery Handling Precautions

(Only when NiMH/NiCd /LiFe batteries are used)

## Warning

- ⊘ Never plug the charger into an outlet of other than the indicated voltage.  
Plugging the charger into the wrong outlet could result in an explosion or fire.
- ⊘ Never insert or remove the charger while your hands are wet.  
You may get an electric shock.
- ⊘ Do not use the T4GRS transmitter's battery, as the receiver's battery.  
Since the transmitter's battery has an overload protection circuit, the output power will be shut down when the high current load is applied. This may result in runaway or fatal crash.
- ❗ Always check to be sure your batteries have been charged prior to operating the model.  
Should the battery go dead while the model is operating, loss of control will occur and create a very dangerous situation.
- ❗ To recharge the transmitter battery, use the special charger made for this purpose.  
Overcharging could cause the battery to overheat, leak or explode. This may lead to fire, burns, loss of sight and many other types of injuries.

## Caution

- ⊘ Do not use commercial AA size NiCd and NiMH batteries.  
Quick charging may cause the battery contacts to overheat and damage the battery holder.
- ⊘ Do not short circuit the battery terminals.  
A short circuit across the battery terminals may cause abnormal heating, fire and burns.
- ⊘ Do not drop the battery or expose it to strong shocks or vibrations.  
The battery may short circuit and overheat; electrolyte may leak out and cause burns or chemical damage.
- ❗ When the model is not being used, always remove or disconnect the battery.  
Leaving the battery connected could create a dangerous situation if someone accidentally turns on the receiver power switch. Loss of control could occur.
- ❗ Always keep the charger disconnected from the outlet while it is not in use.

# Storage And Disposal Precautions

## Warning

- ⊘ Do not leave the radio system or models within the reach of small children.  
A small child may accidentally operate the system. This could cause a dangerous situation and injuries. NiCd batteries can be very dangerous when mishandled and cause chemical damage.
- ⊘ Do not throw NiMH/NiCd/LiFe batteries into a fire. Do not expose batteries to extreme heat. Also do not disassemble or modify a battery pack.  
Overheating and breakage will cause the electrolyte to leak from the cells and cause skin burns, loss of sight, and other injuries.



**!** When the system will not be used for any length of time, store the system with NiMH/NiCd batteries in a discharged state. Be sure to recharge the batteries prior to the next time the system is used.

If the batteries are repeatedly recharged in a slightly discharged state, the memory effect of the NiMH/NiCd battery may considerably reduce the capacity. A reduction in operating time will occur even when the batteries are charged for the recommended time. (After discharge to 1cell E.V.=1V)

**!** When the LiFe batteries will not be used for a long time, to prevent it from deteriorating we recommend that it be kept in about the half capacity state instead of fully charged. Also be careful that the battery does not enter the over-discharged state due to self-discharge.

Periodically (about every 3 months) charge the battery.

### <NiMH/NiCd Battery Electrolyte>

The electrolyte in NiCd/NiMH batteries is a strong alkali. Should you get even the smallest amount of the electrolyte in your eyes, DO NOT RUB. Wash immediately with water, and seek medical attention at once. The electrolyte can cause blindness. If electrolyte comes in contact with your skin or clothes, wash with water immediately.

## Warning

**⊘** Do not store your R/C system in the following places.

- Where it is extremely hot or cold.
- Where the system will be exposed to direct sunlight.
- Where the humidity is high.
- Where vibration is prevalent.
- Where dust is prevalent.
- Where the system would be exposed to steam and condensation.

Storing your R/C system under adverse conditions could cause deformation and numerous problems with operation.

**!** If the system will not be used for a long period of time, remove the batteries from the transmitter and model and store in a cool, dry place.

If the batteries are left in the transmitter, electrolyte may leak and damage the transmitter. This applies to the model also. Remove the batteries from it also to prevent damage.

### <NiMH/NiCd/Li-ion Battery Recycling>

A used battery is a valuable resource. Insulate the battery terminals and dispose of the battery by taking it to a battery recycling center.

## Other Precautions

## Caution

**⊘** Do not expose plastic parts to fuel, motor spray, waste oil or exhaust.

The fuel, motor spray, waste oil and exhaust will penetrate and damage the plastic.

**!** Always use only genuine Futaba transmitters, receivers, servos, ESCs (electronic speed controls), NiMH/NiCd batteries and other optional accessories.

Futaba will not be responsible for problems caused by the use of other than genuine Futaba parts. Use the parts specified in the instruction manual and catalog.

**⊘** Never use the R304SB-E in GP (Engine) models.

Receiver R304SB-E can be used only with EP car.

## Features

### **-Telemetry system**

The T4GRS transmitter has adopted the newly developed bidirectional communication system "T-FHSS"

### **-2.4GHzSS (Spread Spectrum) radio communication system**

Frequency channel setting is unnecessary: Channel shifting takes place within the 2.4GHz band automatically. This system minimizes the interference from other 2.4GHz systems.

### **-Model memory for 40 models**

Model names can use up to 10 letters, numbers, and symbols, so that logical names may be used. A model memory with different setups can be created by using the model copy function.

### **- Menu Selection**

The setup screens are called from menu screens. The menu screen can be selected from among 2 levels (LEVEL1/LEVEL2).

### **-Brake mixing for large cars (BRAKE)**

Brake mixing of the front and rear sticks of 1/5GP and other large cars can be adjusted independently.

### **-4WS mixing for crawlers and other 4WS type (4WS)**

This function can be used with crawlers and other 4WS type vehicles.

### **-Dual ESCs mixing for crawlers cars (DUAL ESC)**

ESC at the front and rear are controlled independently.

### **-Gyro mixing (GYRO MIX)**

The sensitivity of Futaba car rate gyros can be adjusted from the T4GRS.

### **-CPS-1 mixing (CPS MIX)**

LED lighting and flashing control using our CPS-1 channel power switch can be matched to steering and throttle operation by switch only.

### **-Anti-skid braking system (TH A.B.S)**

This function applies the brakes so that the tires of gasoline engine cars, etc. do not lose their grip on the road even when braking at corners.

### **-Throttle acceleration (ACCEL)**

Gasoline engine cars have a time lag before the clutch and brakes become effective. The throttle acceleration function reduces this time lag.



### **-Throttle speed (SPEED)**

Sudden stick operation on a slippery road surface will only cause the tires to spin and the model to not accelerate smoothly. By setting the throttle speed function, operation can be performed smoothly and easily. It also suppresses battery consumption.

### **-Steering speed (SPEED)**

When you sense that the steering servo is too fast, etc., the servo operating speed (direction that suppresses the maximum speed) can be adjusted.

### **-Racing timer (TIMER)**

The lap timer can record 100 lap times and total time. The timer can also be started automatically by stick operation. The race time and audible alarm can be set.

Re-/fueling time are indicated by an audible alarm. An up timer is also provided.

### **-Digital trim**

The current trim position is displayed on the LCD screen. The operating amount of 1 step can also be adjusted.

Trim operation has no effect on the maximum travel of the steering and throttle servos.

### **-Function select switch / dial function (TRIM DIAL)**

This function assigns functions to 2 switches and dials (digital trim, digital dial). The step amount and operating direction can also be adjusted. Trim positioning at each model call is unnecessary because all the dials are digital.

### **-ESC-Link function (MC-LINK)**

This is a dedicated function which allows setting of the contents of the Link software which makes possible Futaba speed controller (ESC), MC950CR, MC850C, MC851C, MC602C, MC402CR, etc. variable frequency and other data changes by T4GRS.

### **-Tension adjustment function**

The tension of the steering stick & throttle stick springs can be adjusted from the inside.

### **-Adjustable Throttle Stick Travel (Mechanical ATL Adjustment)**

Make this adjustment when you want to decrease the total travel of the forward (up) side or brake (down) side of the throttle stick.

### **-Display switch**

Display switch allows function setup without transmitting.

## Set Contents

After opening the box, first check if the contents conform to the following. The contents depend on the set as shown below.

Before Using

<b>Transmitter</b>	<b>T4GRS</b>
<b>Receiver</b>	<b>R304SB or R304SB-E</b> (Built-in Antenna for EP car models)
<b>Miscellaneous</b>	<p><b>Receiver switch</b> * It is not attached to R304 SB-E set.</p> <p><b>Mini screwdriver</b> * It is used for receiver.</p> <p><b>Instruction manual</b></p>

- If any of the set contents are missing, or you have any questions, please contact your dealer.

### **Caution**

**!** When using the T4GRS in the T-FHSS (HIGH) and S-FHSS (HIGH) mode, always use it under the following conditions:

**Servos** :Futaba digital servo (including BLS Series brushless servos)

**Receiver's battery** :Matched to the ratings of the receiver and connected digital servo (dry cell battery cannot be used).

**Transmitter mode** :RX MODE

Under other conditions, the set will not operate, or the specified performance will not be displayed even if it operates. In addition, it may cause servo trouble. Futaba will not be responsible for damage, etc. caused by combination with the products of other companies.

In addition, the FSU Fail Safe Unit cannot be used because the system is different. Use the fail safe function of the transmitter.

**!** When using analog servos, always switch the T4GRS servo response to the "NORM" mode.

**Transmitter mode:**"T-FHSS(NORM)", "T-FHSS(NORM)"and FHSS mode

**Receiver's battery** :Matched to the ratings of the receiver and connected servo (dry cell battery cannot be used).

The set cannot operate in the "HIGH" mode. Operation in this mode will cause trouble with the servo and other equipment.

Digital servos (including BLS Series brushless servos) can also be used in the "NORM" mode.

**!** Always use only genuine Futaba transmitters, receivers, servos, ESCs (electronic speed controls), NiMH, NiCd, Li-ion batteries and other optional accessories.

Futaba will not be responsible for problems caused by the use of other than Futaba genuine parts. Use the parts specified in the instruction manual and catalog.

# Transmitter T4GRS

## Nomenclature

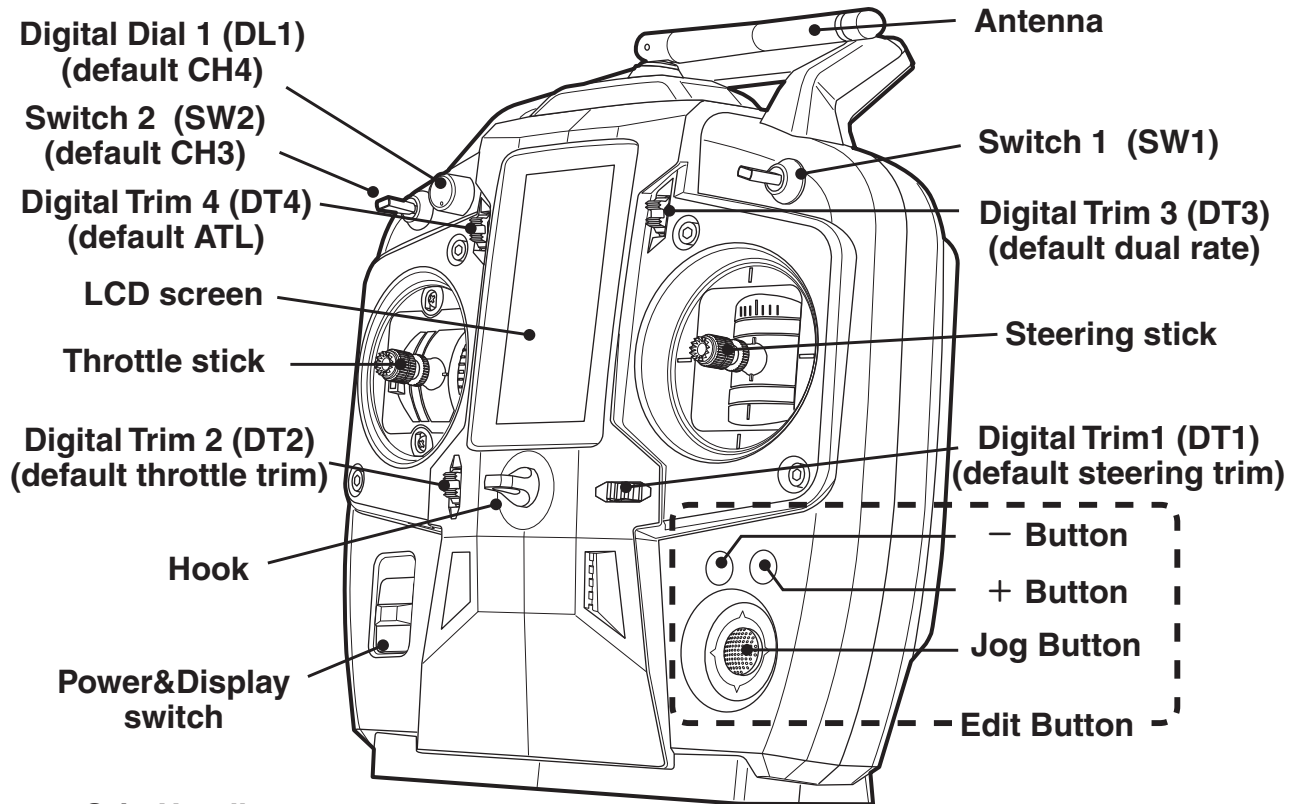

Before Using

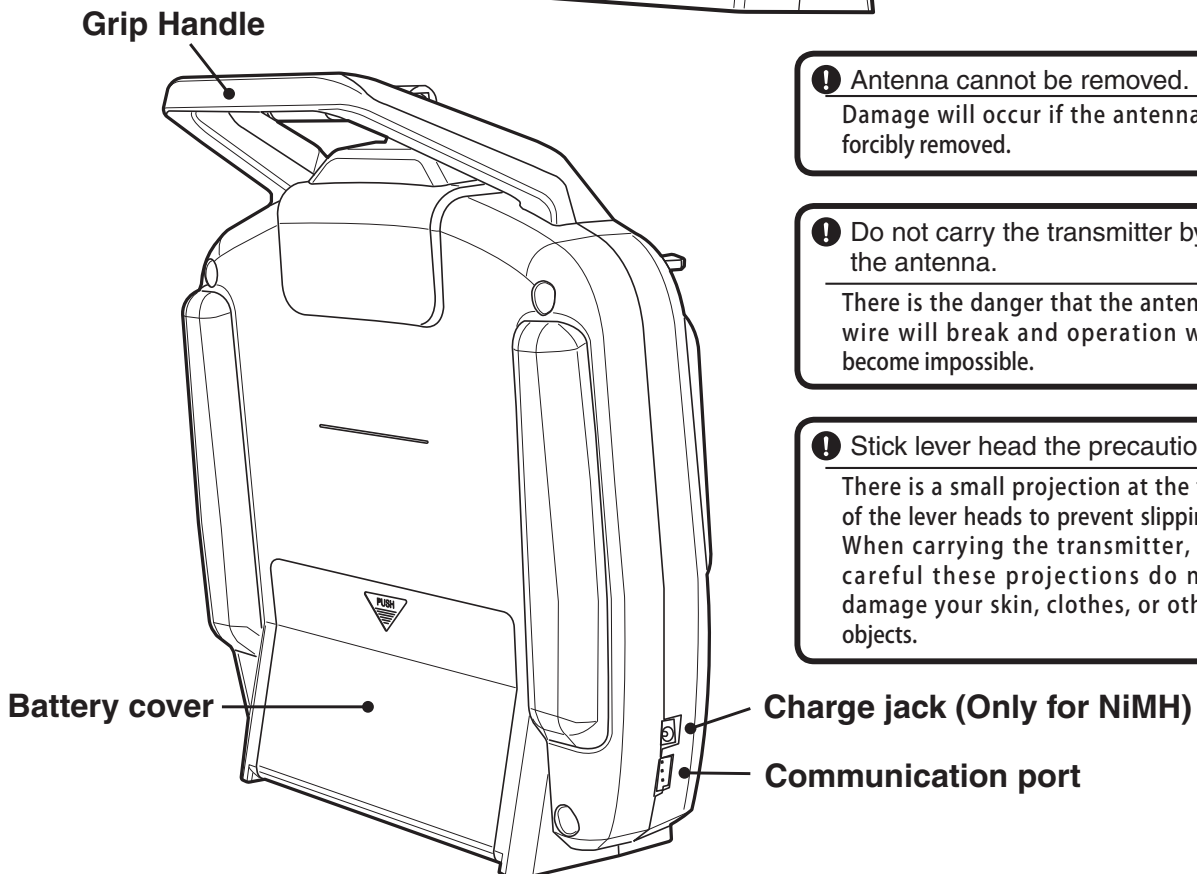

**!** Antenna cannot be removed.  
Damage will occur if the antenna is forcibly removed.

**!** Do not carry the transmitter by the antenna.  
There is the danger that the antenna wire will break and operation will become impossible.

**!** Stick lever head the precautions.  
There is a small projection at the tip of the lever heads to prevent slipping. When carrying the transmitter, be careful these projections do not damage your skin, clothes, or other objects.

\*The switches, dial, and trimmers in the figure are shown in the initial setting position.

## Battery Replacement Method (4 AA Size Batteries)

Load the four batteries in accordance with the polarity markings on the battery holder.

### Battery Replacement Method

- 1 Remove the battery cover from the transmitter by sliding it in the direction of the arrow in the figure.
- 2 Remove the used batteries.
- 3 Load the new AA size batteries. Pay very close attention to the polarity markings and reinsert accordingly.
- 4 Slide the battery cover back onto the case.

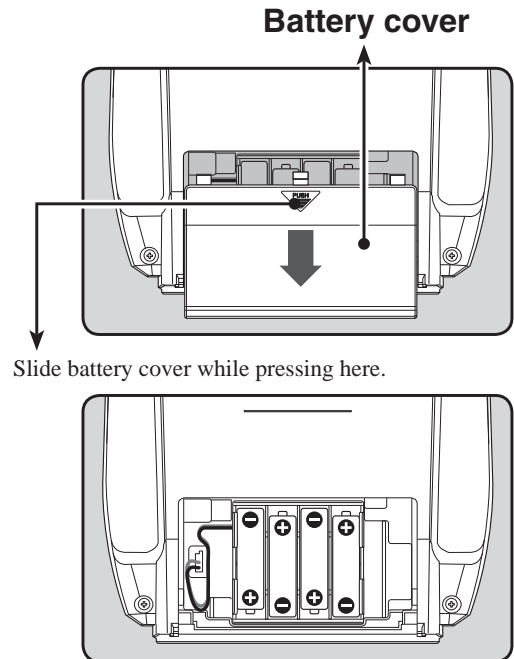

### Check:

Turn the power switch on the transmitter to the ON position. Check the battery voltage display on the LCD screen. If the voltage is low, check the batteries for insufficient contact in the case or incorrect battery polarity.

### Disposal of the Dry Cell Batteries:

The method to dispose of used dry cell batteries depends on the area in which you reside. Dispose of the batteries in accordance with the regulations for your area.

## ⚠ Caution

- ⊘ Never try to recharge a dry cell battery.  
The transmitter may be damaged or the battery electrolyte may leak or the battery may break.
- ⓘ Insert the batteries in the correct polarity.  
If the polarity is incorrect, the transmitter may be damaged.
- ⊘ When the transmitter is not in use, remove the batteries.  
If the battery electrolyte leaks, wipe off the case and contacts.
- ⊘ Do not use commercial AA size NiCd and NiMH batteries.  
Quick charging may cause the battery contacts to overheat and damage the battery holder.

Use prohibited

AA size Ni-cd    AA size Ni-MH

## When Using The Optional Battery

When using an optional rechargeable battery, replace the battery as described below.

- Always use the optional HT5F1800B or FT2F1700BV2/2100BV2 rechargeable battery.
- The type of power source used must be set by system setting.
- When the transmitter will not be used for a long time, remove the battery.

### Battery Replacement Method

- 1** Refer to the previous description and remove the transmitter battery cover.
- 2** After removing the dry cell battery box from the transmitter, disconnect the connector.
- 3** Insert the connector of the new battery and load the new battery into the transmitter.
- 4** Finish by installing the battery cover.



### Caution

- 1** When closing the battery cover, be careful that the battery cover does not pinch the battery lead wires.

Shorting of the battery lead wires may lead to fire and abnormal heating and cause burns or fire disaster.

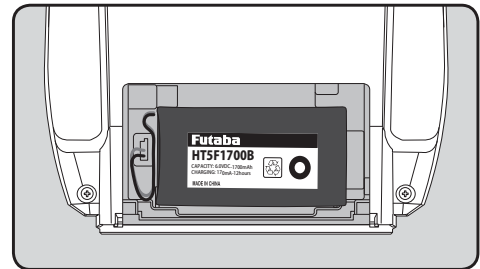
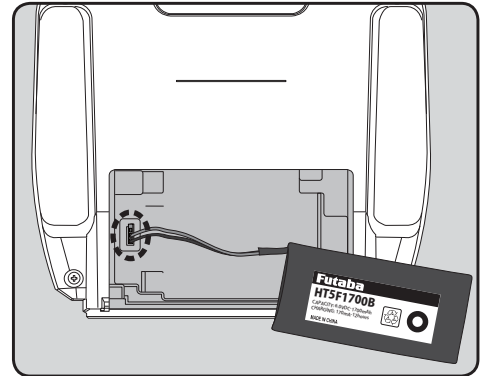

Before Using

# When Charging the Optional Battery

## Charging a NiMH Battery

(Example: When using the HT5F1800B with the special charger)

- 1 Plug the transmitter cord of the special charger into the charging jack on the rear of the transmitter.
- 2 Plug the charger into an AC outlet.
- 3 Check that the charging LED lights.

The charging time when charging the HT5F1800B battery with the optional special charger is approximately 15 hours. However, when the battery has not been used for some time, repeat charging 2 or 3 times to activate the battery.

## Over current protection

The transmitter charging circuit is equipped with an over current protection circuit (1.0A). If the battery is charged with a quick charger for other than digital proportional R/C sets, it may not be fully charged.

## Charging A LiFe Battery

(Example: When using the FT2F1700BV2/2100BV2 with the special charger)

- 1 Remove the battery cover.
- 2 Disconnect the battery from the 4GRS
- 3 Balance charging cannot be done through the transmitter, you must remove the LiFe battery to do this charge.

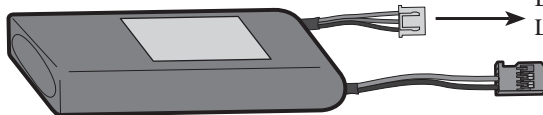

**LiFe battery is removed from transmitter.**

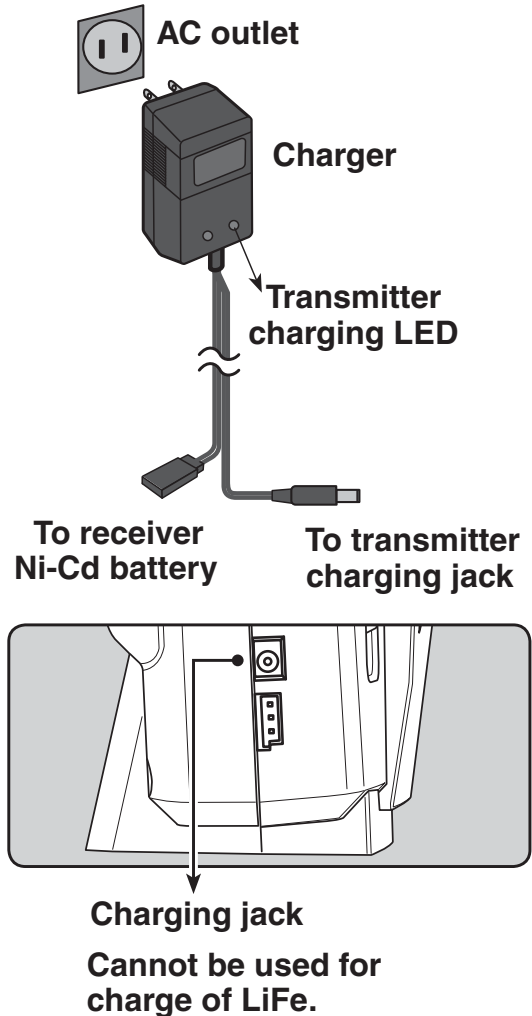

Charge the optional FT2F1700BV2/2100BV2 (LiFe) battery with the special charger in accordance with the instruction manual supplied.

When the battery will not be used for a long time, to prevent it from deteriorating we recommend that it be kept in about the half capacity state instead of fully charged. Also be careful that the battery does not enter the over-discharged state due to self-discharge. Periodically (about every 3 months) charge the battery.



## Warning

- ⊘ Never plug it into an outlet other than the indicated voltage.  
Plugging the charger into the wrong outlet could result in an explosion or fire.
- ⊘ Do not insert and remove the charger when your hands are wet.  
It may cause an electric shock.
- ⓘ Always use the special charger or a quick charger for digital proportional R/C sets to charge a digital proportional R/C set NiMH battery.  
Overcharging a Ni-MH battery can result in burns, fire, injuries, or loss of sight due to overheating, breakage, or electrolyte leakage.

## Caution

- ⊘ When the charger is not in use, disconnect it from the AC outlet.  
Do this to prevent accidents and to avoid overheating.

## Low Battery Alarm

If the transmitter battery voltage drops below the usable range, an audible alarm will sound and "BATTERY LOW VOLTAGE" will be displayed on the LCD screen. If the battery goes dead while running (cruising), you will lose control of the vehicle (boat). Therefore, retrieve the vehicle (boat) immediately and cease operation.

Because the low battery alarm voltage of a dry cell battery is different from that of a rechargeable battery pack (genuine Futaba option), the type of power source used must be set by system setting.

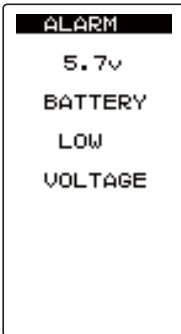

## Warning

- ⓘ When a low battery alarm is generated, cease operation immediately and retrieve the model.  
If the battery goes dead while in operation, you will lose control of the model.

## Power & Display Switch

The power switch and display switch of the T4GRS are integrated. In the PWR ON mode, radio waves are transmitted and in the DISP mode, model data, settings can be checked without transmitting radio waves.

In addition, some setting menus may only be displayed in the DISP mode.

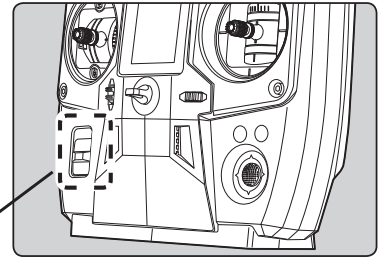

Power / DISP Switch

Before Using

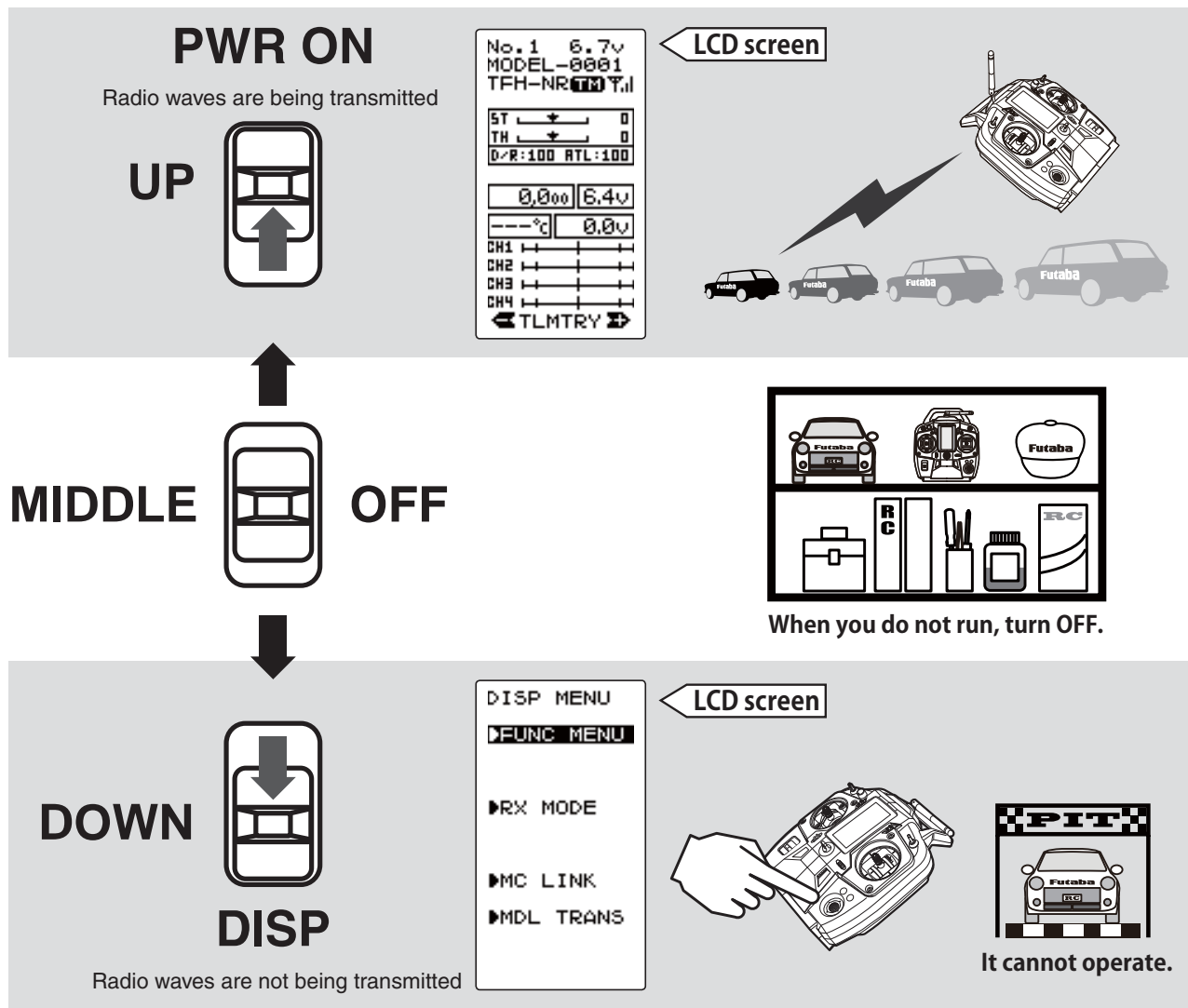

### Precautions when turning the power switch on and off.

- When the data is changed using the edit buttons or trim levers, wait at least two seconds before turning off the power. If the power is turned off within two seconds after the data is changed, the new data will not be written to memory.

- If the power switch is quickly switched from the DISP mode to the PWR ON mode or vice versa, the switch error shown at the right may be generated. If this occurs, cycle the power.



## Display When Power Switch Is Turned On

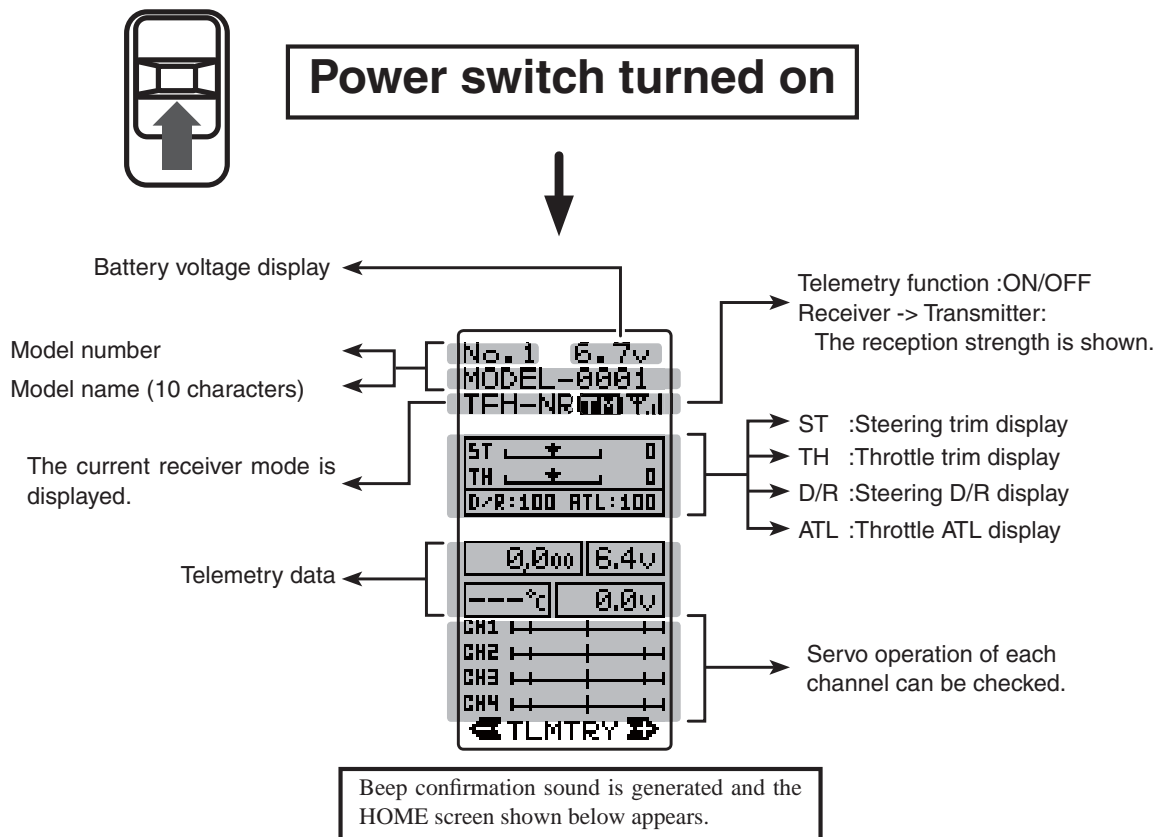

Before Using

## LCD Screen Contrast

The LCD screen contrast can be adjusted.

### Caution

Do not adjust the contrast so that the LCD is too bright or too dark.  
When the display cannot be read due to a temperature change, data cannot be set.

## Alarm Setting if Tx is left switched ON

When the steering stick, throttle stick, push switch, or edit button are not operated for 10 minutes (default), an alarm sounds and "NOT OPERATED FOR A LONG TIME" is displayed on the LCD screen.

When the steering stick, throttle stick, push switch, or edit button are operated, the alarm is reset. If the system is not to be used, turn off the power.

The function can be deactivated in the system menu.

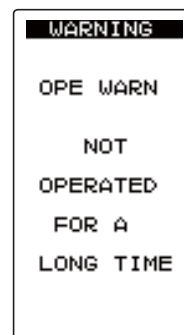

# Stick Operation CH1 CH2

(CH1: Steering stick, CH2: Throttle stick,)

Throttle Stick Function: Controls the speed of the model as well as the direction of travel  
- forward or reverse.

Steering Stick Function: Turns the model right or left.

Before Using

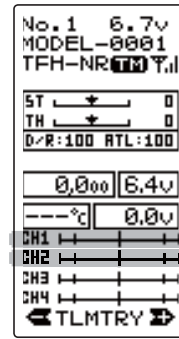
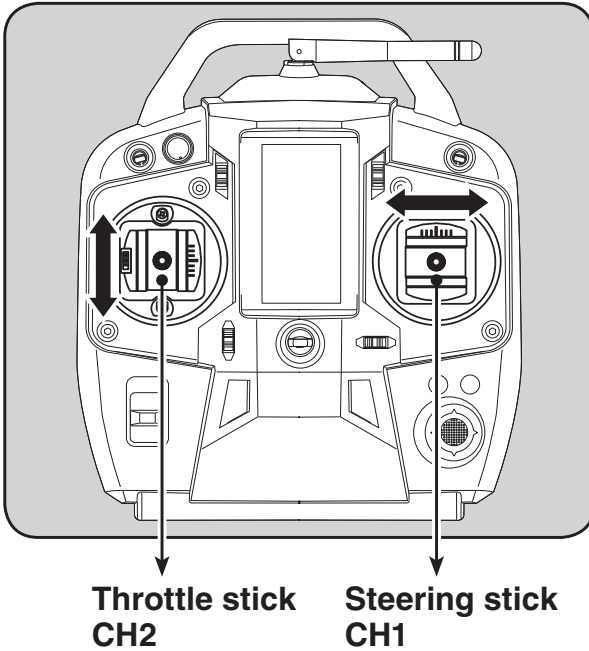

Servo operation of steering channel (CH1) can be checked.  
Servo operation of throttle channel (CH2) can be checked.

## Throttle stick function

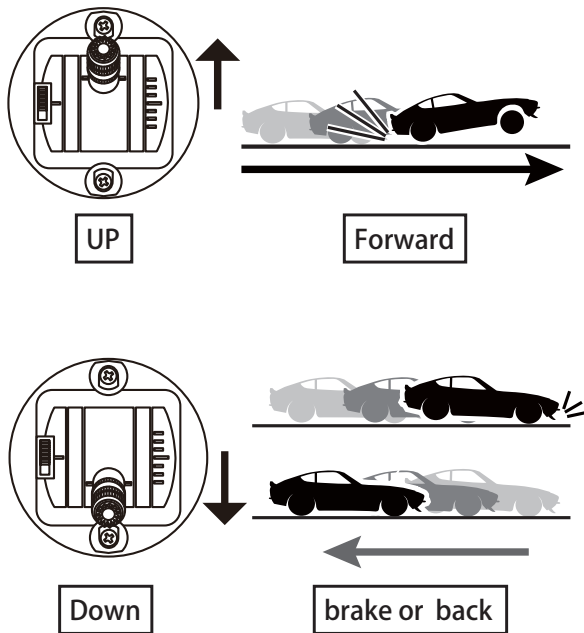

## Steering stick function

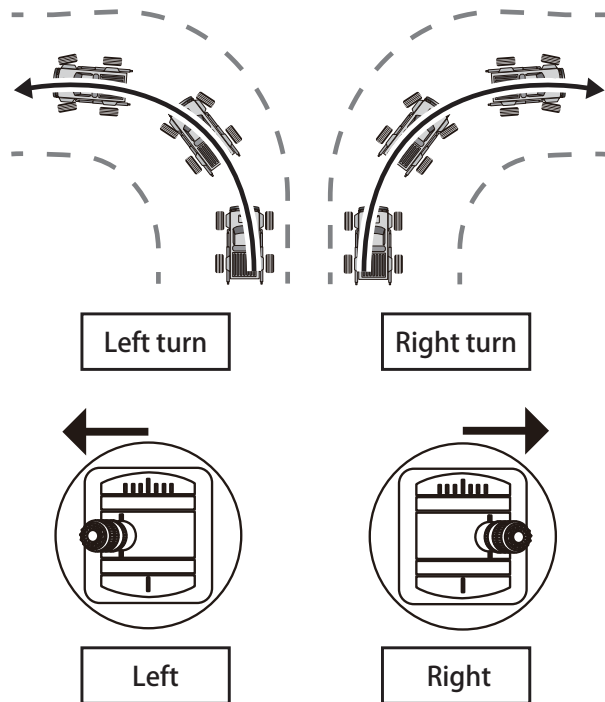

( RC Car example shown )

# Switch Dial Operation CH3 CH4

(CH3: Switch SW2, CH4: Dial DL1)

The three-position switch SW2 will result in the servo arm moving to three different positions when operated.

Note that this function cannot be assigned to the spring return switch SW1.

Rotating the Dial (DL1) will proportionally control a servo on CH4. → The SW2 switch and DL1 dial can be assigned to either function.

Switch (SW2) 3position    Dial (DL1)    Switch (SW1) Return

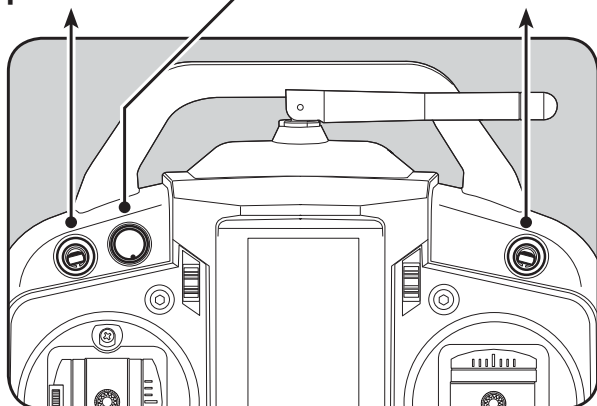

The function cannot be assigned to SW1

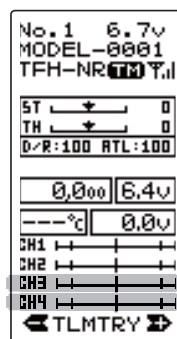

Operation of CH3 can be checked.

Operation of CH4 can be checked.

## Initial setting

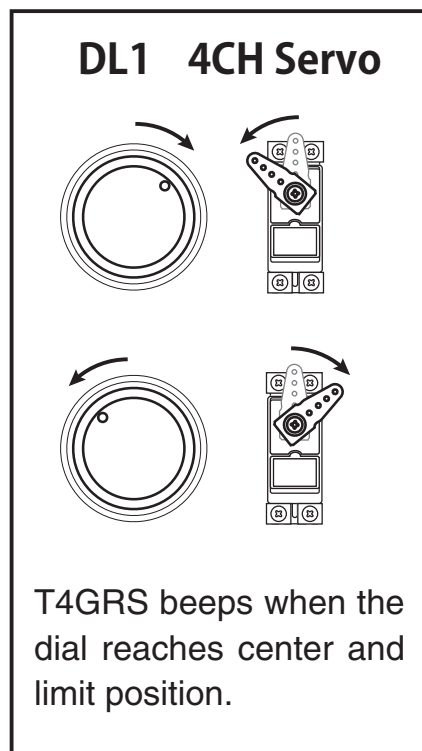
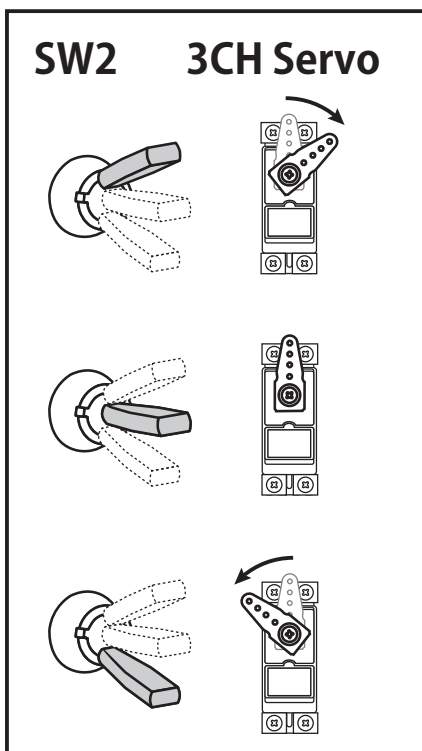

•The servo arm position and dial do not necessarily always match exactly.

Before Using

## Digital Trim Operation DT1 DT2

(Initial settings: DT1: Steering trim, DT2: Throttle trim,)

Operated by the lever: Push the lever to the left or right (up or down) The current position is displayed on the LCD screen.

Before Using

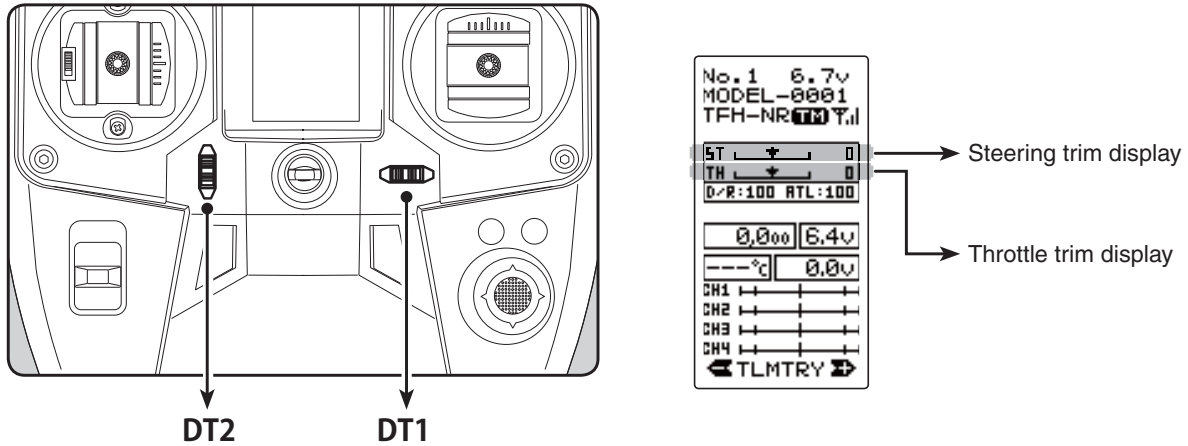

- Each step is indicated by a tone.
- When the trim exceeds the maximum trim adjustment range, the beep will change and the servo will not move any farther.
- Trim lever adjustments have no effect on the maximum servo travel. This prevents the linkages from binding when adjustments are made.

### Trim Operation

With the center trim feature, trim adjustments have no effect on the maximum servo travel. This prevents the linkages from binding when adjustments are made.

## Digital Trim Operation DT3 DT4

(Initial setting: DT3; Steering D/R, DT4; ATL)

Operated by the lever: Push the lever to up or down. The current position is displayed on the LCD screen.

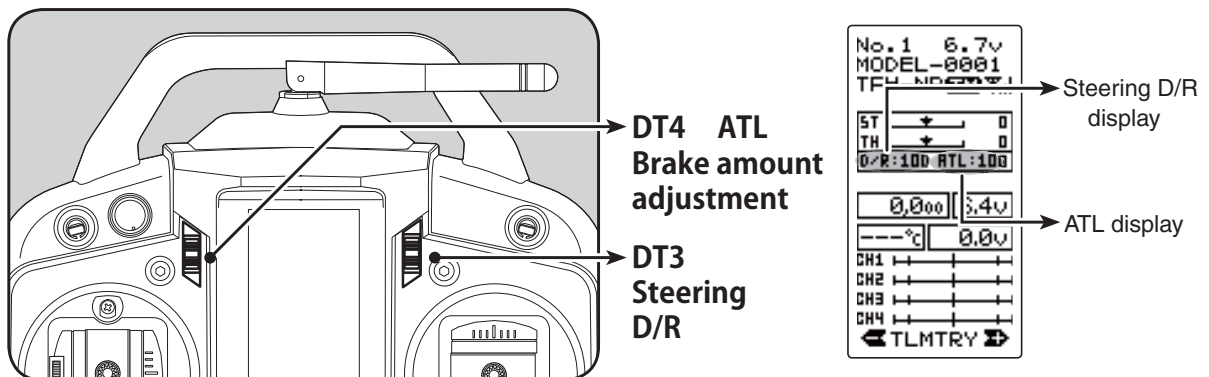

- Each step is indicated by a tone.
- When the trim exceeds the maximum trim adjustment range, the tone will change pitch and the servo will not move any farther.

## Stick Lever Head Adjustment

The length of the lever head of the steering and throttle sticks can be adjusted.

### Adjustment

**1** Unlock lever head "A" by turning it counterclockwise.

**2** Adjust the head to the length best for you, then lock the heads by turning lever head "A" clockwise and lever head "B" counterclockwise.

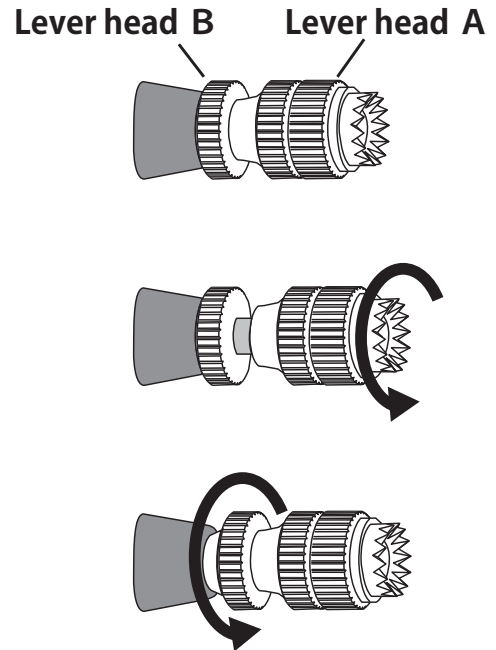

Before Using

## Stick Mounting Angle Adjustment

The mounting angle of the throttle and steering sticks can be adjusted.

### Setting

**1** Loosen the two set screws.

**2** Change the stick angle.

**3** Re tighten the two set screws.

- The figure at the right shows the throttle stick. The steering stick can adjusted similarly.

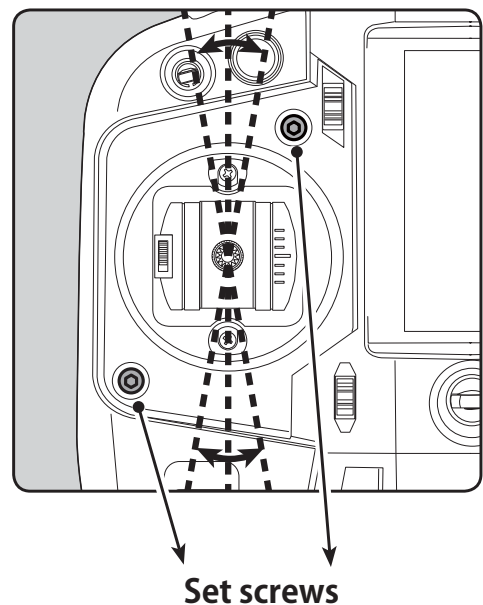

## Stick Tension Adjustment

Make this adjustment when you want to change the steering stick or throttle stick spring tension.

### Adjustment

**1** Remove the battery from the transmitter.

**2** Using Phillips screwdriver, as shown in a figure, four screws are removed, and a rear case is removed.

- Don't touch internal electronic components.

**3** Turn the adjusting screw using a small Phillips screwdriver such as a watchmaker's screwdriver.

- Turning the adjusting screw clockwise, increases the spring tension.
- The adjustment range is about five turns in both directions, from the initial position.

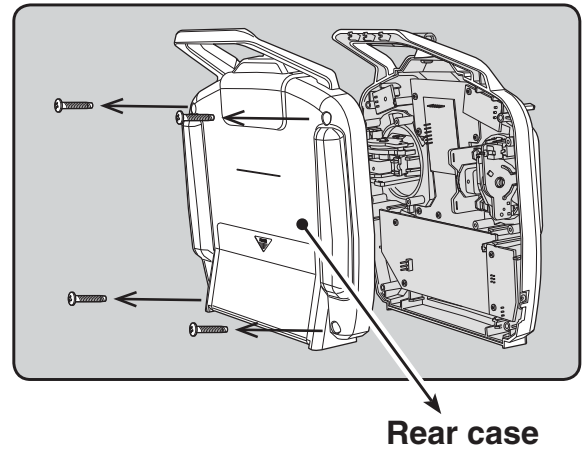

Rear case

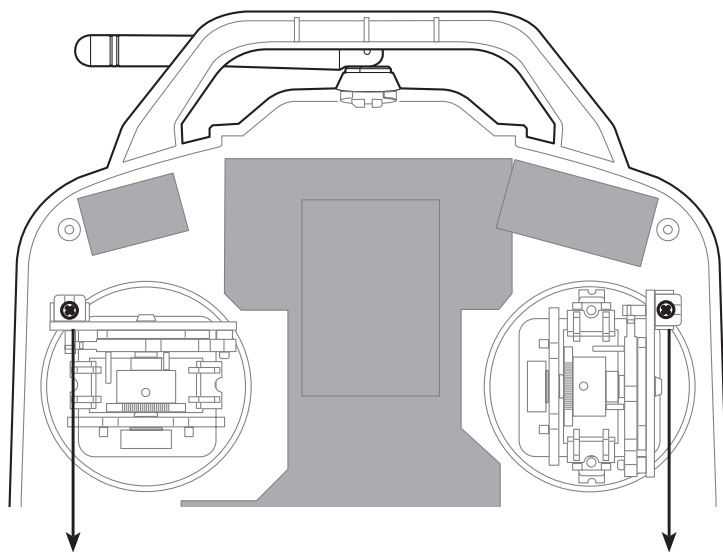

Steering stick adjusting screw

Throttle stick adjusting screw

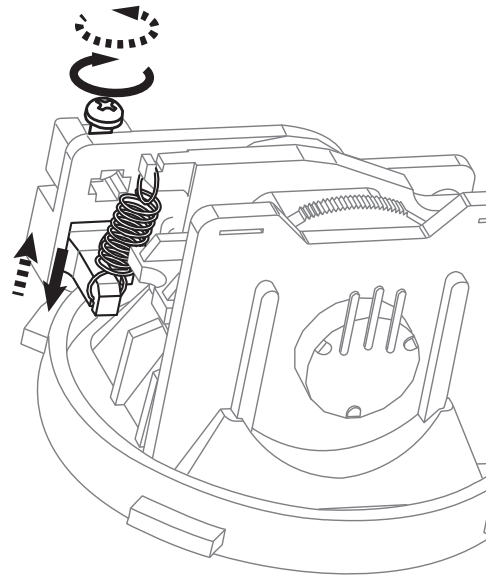

**4** When the adjustment is completed, re-attach the rear case with a Phillips screwdriver.

- Take great care not to damage the wiring when re-attaching the rear case.
- Foreign substances must not be allowed to get into the interior of the case.

### Caution

If turned too far counterclockwise, the adjusting screw may fall out.



# Mechanical Throttle Stick Stroke Adjustment

Make this adjustment when you want to reduce the throttle stick range at the full power or brake/reverse positions.

## Stick stroke adjustment

**1** Make this adjustment by turning the adjusting screw above the stick with a Phillips screwdriver.

- When the adjusting screw is turned counter clockwise, the stroke is reduced.

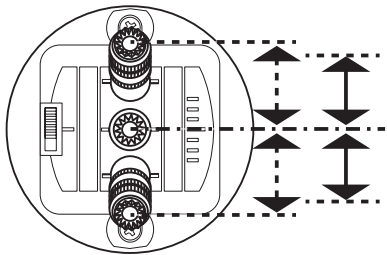

Stroke can be reduced mechanically.

Brake (reverse) side

High side

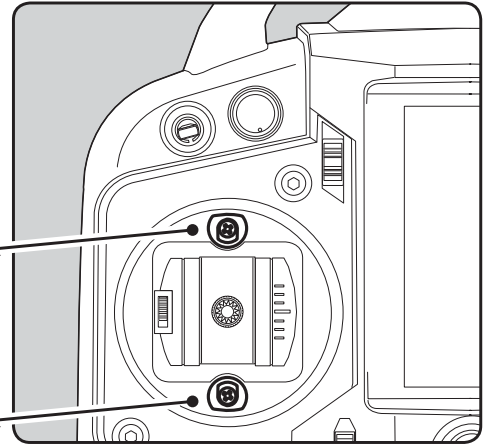

Before Using

**2** On the MENU2 screen, select the setting item "ADJUSTER" using the (JOG) button, and pressing the (JOG) button.

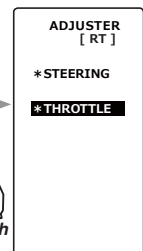
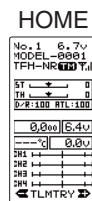

**3** (Selection of THROTTLE)

Move the cursor to "THROTTLE" using the (JOG) button up or down function, and pressing the (JOG) button.

**4** (Throttle 5:5 neutral adjustment)

Neutral adjuster is set to 5:5 the Neutral Adjuster switch (see next page). In the 5:5 neutral setup screen (fig-1) state, pull the stick back slightly then allow to return to neutral and press the (JOG) button whilst ensuring the stick is not touched.

**5** (Throttle 7:3 neutral adjustment)

Neutral adjuster is set to 7:3 by the Neutral Adjuster switch (see next page). In the 7:3 neutral setup screen (fig-2) state, pull the stick back slightly then allow to return to neutral and press the (JOG) button whilst ensuring the stick is not touched.

Note that both the 5:5 and 7:3 neutral adjustment procedures have to be completed as part of the set-up process. Once complete the required option should be selected.

**6** (Throttle throw adjustment)

In the throw setup screen state (fig-3), gently move the stick fully to the brake /reverse and full power positions and when button

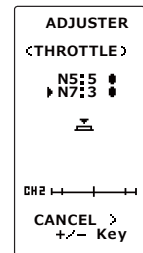
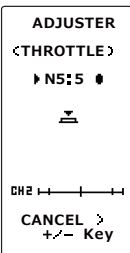
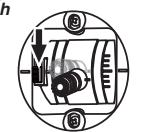
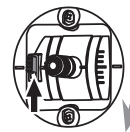
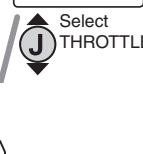
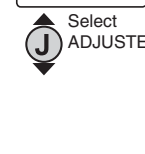

fig-1

fig-2

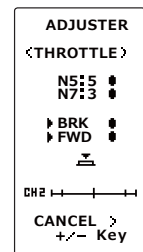
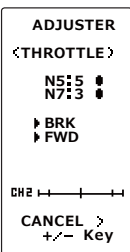

fig-3

fig-4

mark (fig-4) is displayed, pressing the (JOG) button.

An internal check is performed automatically. When each adjustment point is within a fixed range, correction is performed and "COMPLETE!" (fig-5) is displayed.

If an adjustment point is not within a fixed range, correction is not performed and the correction data is not updated.

If the stroke is made too narrow, this will cause an error.

In that case, extend the stroke.

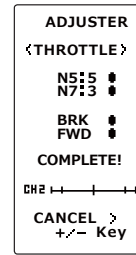

fig-5

**7** When complete, return to the ADJUSTER screen by press the (JOG) button.

**8** Next, move the cursor to [RT] by the (JOG) button, and press the (JOG) button.

**Caution**

When the stroke is adjusted, the throttle servo travel should also be adjusted electronically. If the stroke is mechanically reduced too far the adjusting screw may fall out.

## Neutral Adjuster Operation

The neutral adjuster selects the throttle stick neutral position.

**1** Neutral adjuster is set to 5 : 5 when in the upper position. It will be set to 7 : 3 when moved to the lower position

- If 7 : 3 is used, the neutral to full power stick range is increased.

**Caution**

When a neutral adjuster change is made, be sure to carry out system change.

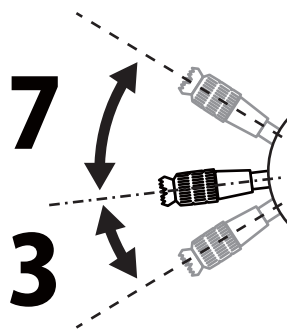
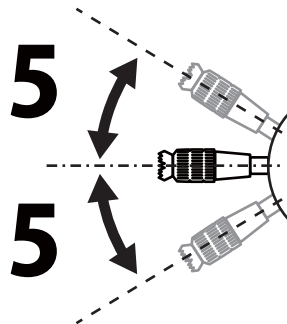

**Neutral Adjuster**

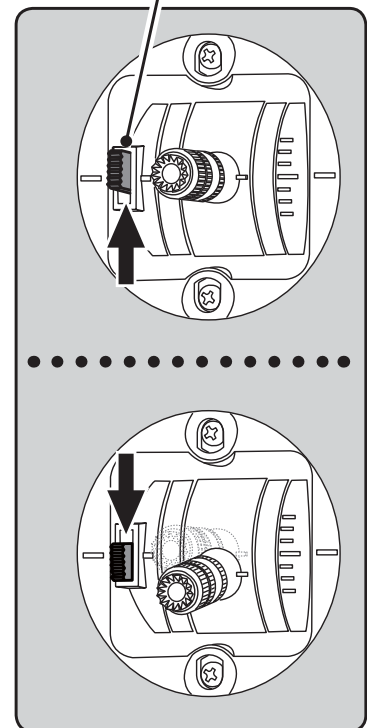

**2** On the MENU2 screen, select the setting item "SYSTEM" using the (JOG) button, and press the (JOG) button.

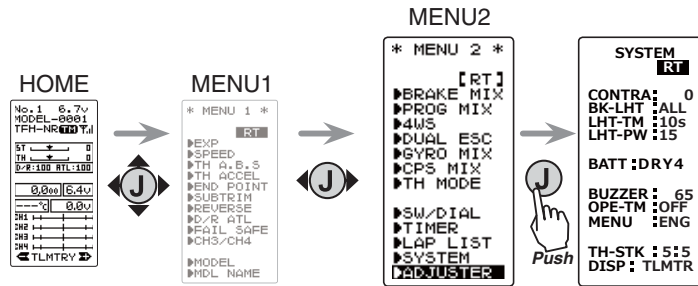

### 3 (Selection of TH-STK)

Move the cursor to "TH-STK" using the (JOG) button up or down operation.

### 4 (Selection of your 4GRS neutral position)

Use the (+) and (-) buttons to select either 5:5 or 7:3.

- "F10" should be selected only when using a ratchet on the throttle stick. (for GP boats)

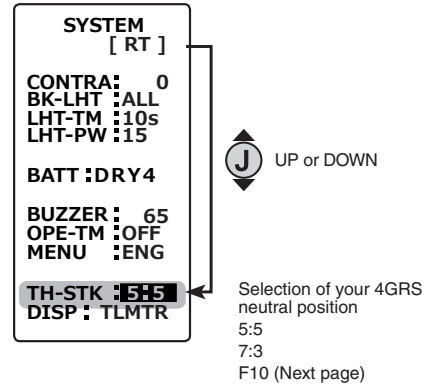

### 5 (Neutral position execution)

Press the (JOG) button for about 1 second. A beeping sound is generated and the neutral position is selected.

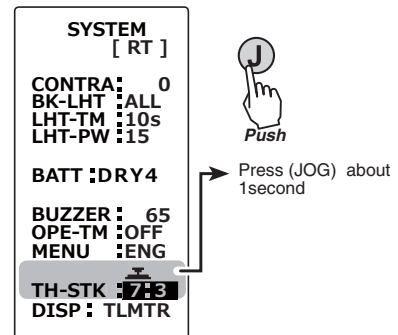

### 6 When completed, return to the MENU2 screen by pressing the (JOG) button.

### 7 Next, move the cursor to [RT] using the (JOG) button, and press the (JOG) button.

## Changing to Ratchet Type Throttle Stick

Changing the throttle stick from the self-centering type to ratchet type that stops at an arbitrary position. (To make this modification, the optional ratchet plate must be purchased.)

### Adjustment

**1** Remove the battery from the transmitter.

**2** Using Phillips screwdriver, as shown in a figure, four screws are removed, and the rear case is removed.

- Don't touch internal electronic components.

**3** Remove the swing arm, spring and spring hook from the throttle stick as shown in the figure.

- Retain these parts in case the stick is to be changed back to self-centering type later.

**4** Install the ratchet plate to the throttle stick.

- The V section of the direction of a ratchet plate is downward.

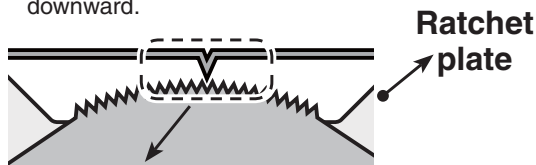

- If the ratchet action is too harsh, a small amount of servo gear grease should be applied to the ratchet teeth.

**5** Fasten by twisting the retaining tabs with needle-nosed pliers.

**6** When the work is completed, re-attach the rear case using a Phillips screwdriver.

- Take great care not to damage the wiring when re-attaching the rear case.
- Foreign substances must not be allowed to get into the interior of the case.

### Caution

\*If TH-STK is changed to F10 (see previous page), the now unnecessary brake function can be disabled.

\*If the throttle stick is not in the stop/idle position when the transmitter is switched "ON" an alarm will sound. Ensure that the throttle stick is in the stop/idle position when switching "ON" - if the alarm sounds the throttle output will default to stop/idle.

\*The adjustment of the throttle range cannot be carried out if a ratchet is being used, only if the throttle stick is self-centering.

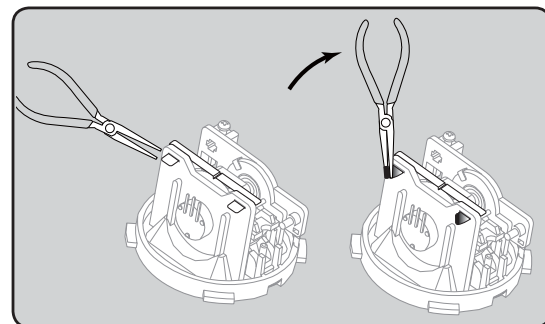
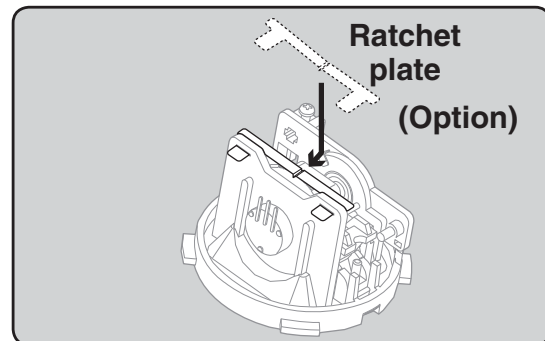
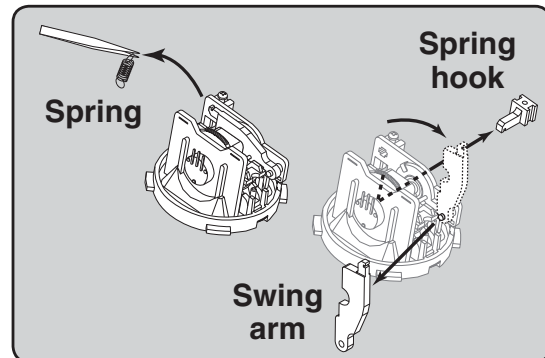
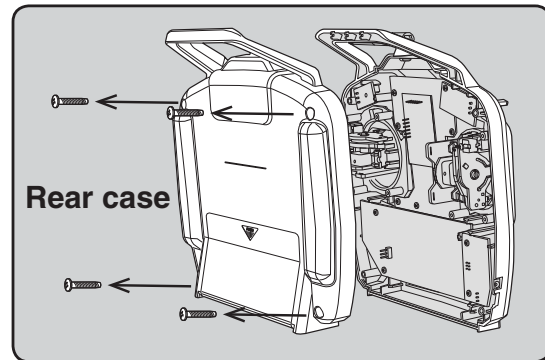

# About Transmitter Antenna and Receiver

## About The Transmitter Antenna

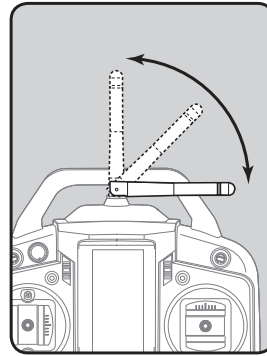
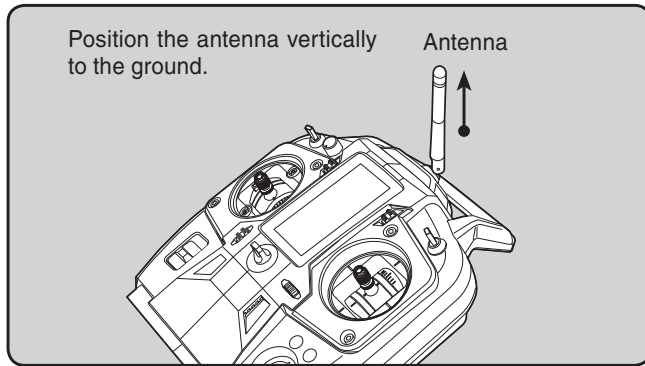

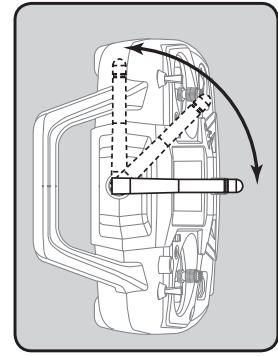

A



B

Antenna Moving Range

### Warning

-  **Position the antenna vertically to the ground.**  
In other positions the operating range may be reduced.
-  **Never hold only the antenna.**  
Hold the grip handle. Otherwise, the antenna may be damaged.
-  **The antenna position can be changed in the range as shown in figures A and B. However, please do not apply unnecessary force or shock.**  
The internal cable may be damaged; thus transmitting distance is reduced and this may result in faulty operation.

Before Using

# Receiver Terminology

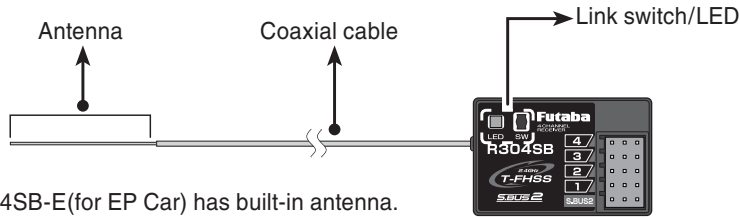

\*R304SB-E(for EP Car) has built-in antenna.

**R304SB**

## Connectors

- 4 :CH4 servo(CH4)
- 3 :CH3 servo(CH3)
- 2 :Throttle servo(CH2)
- 1 :Steering servo(CH1)
- S.BUS2:Power /S.BUS2 connector

The receiver power supply can be connected to the S-BUS2 connector or any of CH1-4.

# Receiver Installation

Install the R304SB receiver on the car as follows:

The operating range may reduced, depcompleted on where the receiver and the antenna are mounted.

Before Using

## WARNING

- ⊘ Do not cut or bundle the receiver antenna wire.
- ⊘ Do not bend the coaxial cable. It causes damage.
- ❗ Install the antenna in the highest position possible as shown in the figure.
- ❗ Put the antenna in the antenna tube to protect it.
- ❗ Keep the antenna as far away from the motor, ESC and other noise sources as you possibly can.
- ❗ Wrap the receiver with something soft, such as foam rubber, to avoid vibration. If there is a chance of getting wet, put the receiver in a waterproof bag or balloon.

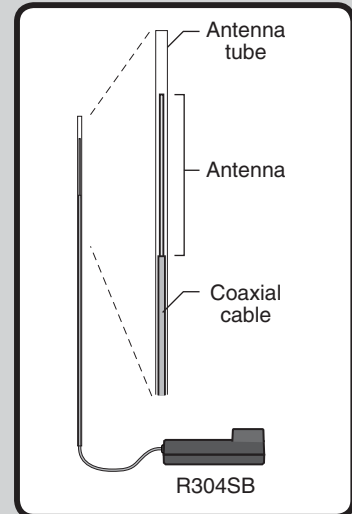

## Caution

- ❗ Always use R304SB,R304SB-E under the following conditions:
  - Battery :Power requirement Rated voltage 4.8~7.4V (dry cell battery cannot be used)
  - Matched to the ratings of the receiver and connected servo.
  - RX MODE:"T-FHSS(HIGH)" or "T-FHSS(NORM)"
  - Transmitter mode-"T-FHSS(HIGH)" mode :Futaba digital servo
  - Transmitter mode-"T-FHSS(NORM)" mode :Futaba all servo

Under other conditions, the set will not operate, or the specified performance will not be displayed even if it operates. In addition, it may cause trouble with servos and other equipment. Futaba will not be responsible for damage, etc. caused by combination with the products of other companies.

### Transmitter mode setting

Set the transmitter to the "T-FHSS(HIGH)" mode or "T-FHSS(NORM)" mode.

**Note:** Only digital servos (including BLS Series Brushless servos) can be used in the T-FHSS(HIGH) mode.

## Receiver and Servo Connections

Connect the receiver and servos as shown below. Connect and install the receiver and servos in accordance with "Installation Safety Precautions" on the next page.

The figure shown below is an example. The method of connecting the motor controller to the motor and battery depends on the motor controller used. Purchase the motor controller and servos separately. The receiver also depends on the set.

### Installation When An Electronic Speed Control Is Used

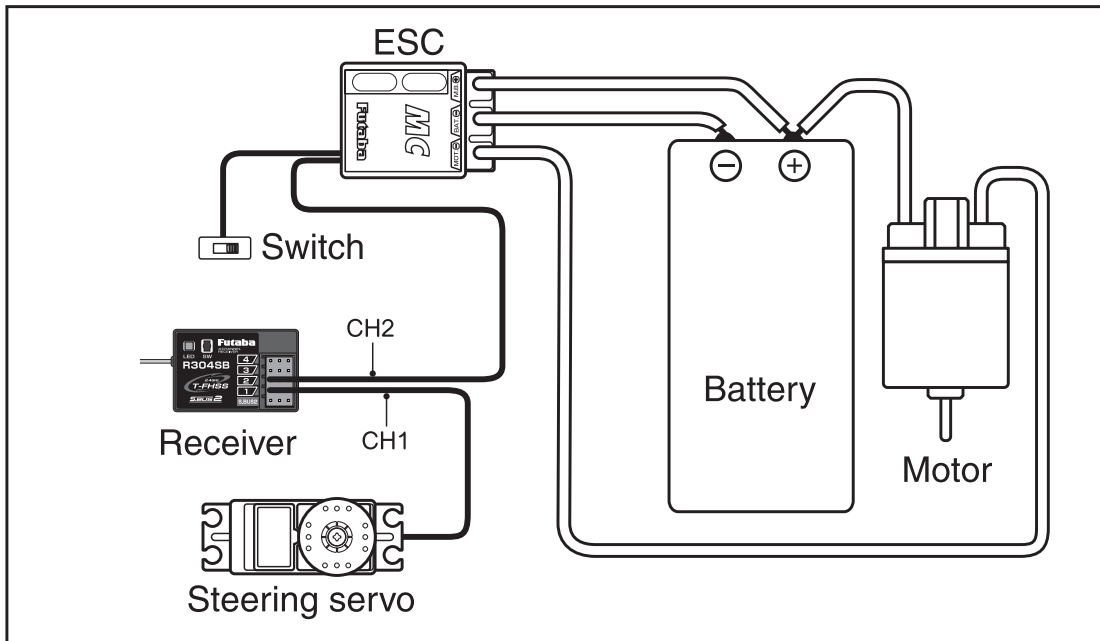

### Installation For Gas Powered Models

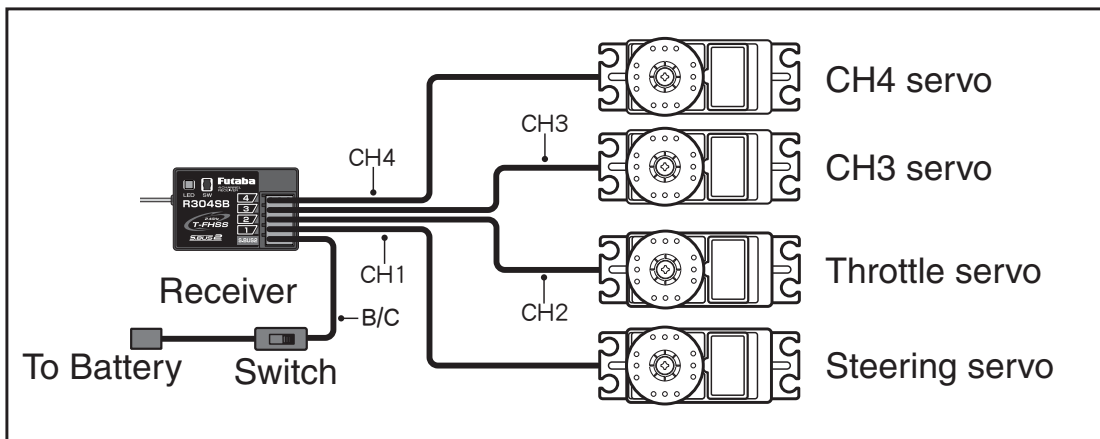

# Installation Safety Precautions

## Warning

### Receiver (receiver antenna)

- ⊘ Do not cut or bundle the receiver antenna wire.
- ⊘ Do not bundle the receiver antenna wire together with the motor controller lead wire.
- ❗ Keep the receiver antenna wire at least 1cm away from motor, battery, and other wiring carrying heavy current.
- ❗ Install the receiver antenna holder as closely as possible to the receiver.

If the antenna wire is cut, bundled, or routed near a noise source, the receiving sensitivity will drop, the running (sailing) range will decrease, and you may lose control of the model.

\*Noise is transmitted through metal, carbon, and other conductive material, so keep the receiver antenna wire away from such parts.

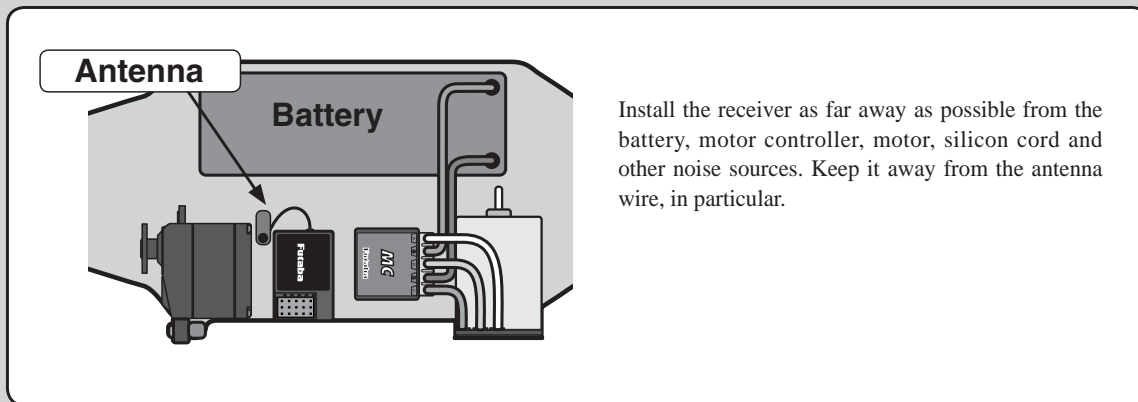

Installation

### Receiver vibration-proofing / waterproofing

(Car)

- ❗ Vibration-proof the receiver by wrapping it in foam rubber or other vibration-absorbing material and mount it with thick double-sided tape.
- ❗ When using the receiver holder supplied with the model kit, mount the holder to the chassis through a rubber grommet.

(Boat)

- ❗ Vibration-proof the receiver by wrapping it in foam rubber or other vibration-absorbing material. Also waterproof the receiver by sealing it in a plastic bag.

If the receiver is exposed to strong vibration and shock, or suffers from water leakage, reliable operation may be lost and you may lose control of the model.

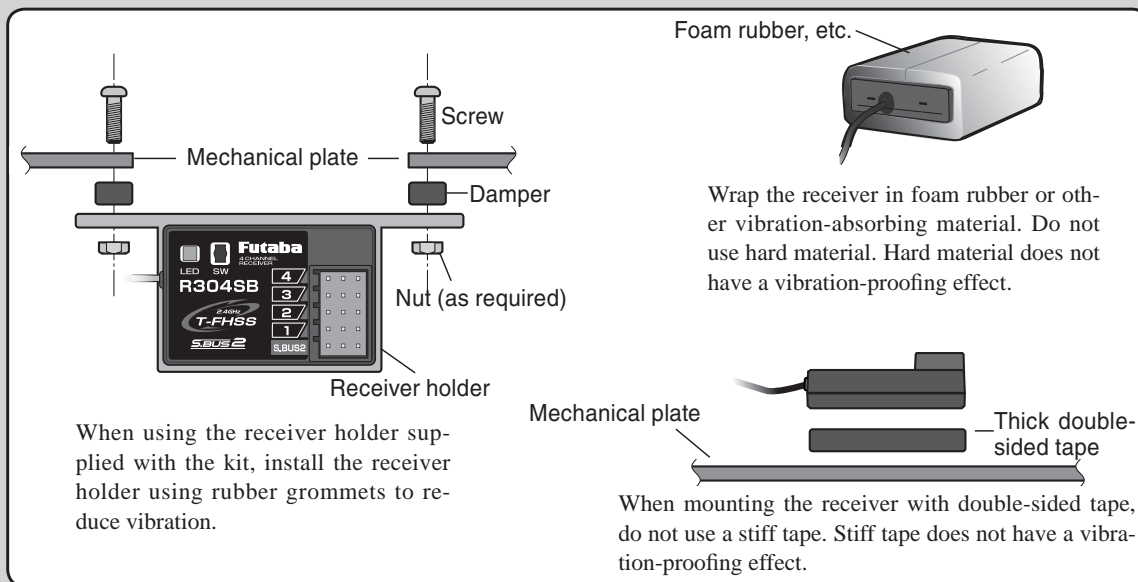



## Warning

### Connector Connections

- ❗ Be sure the receiver, servo, battery and connectors are fully and firmly connected.  
If vibration from the model causes a connector to work loose while the model is in operation, you may lose control.

### Servo Installation

- ❗ When you install the servos, always use the rubber grommets provided in servo hardware bags. Mount the servos so they do not directly come in contact with the mount.  
If the servo case comes in direct contact with the mount, vibration will be directly transmitted to the servo.  
If this condition continues for a long time, the servo may be damaged and control will be lost.

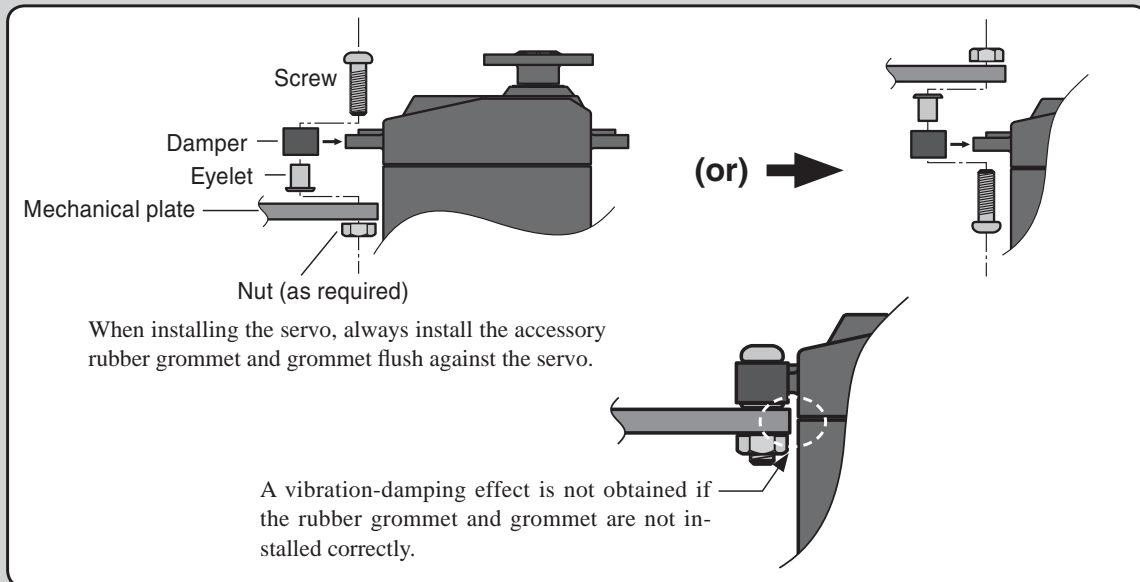

### Servo Throw

- ❗ Operate each servo over its full stroke and be sure the linkage does not bind or is loose.  
The continuous application of unreasonable force to a servo may cause damage and excessive battery drain.

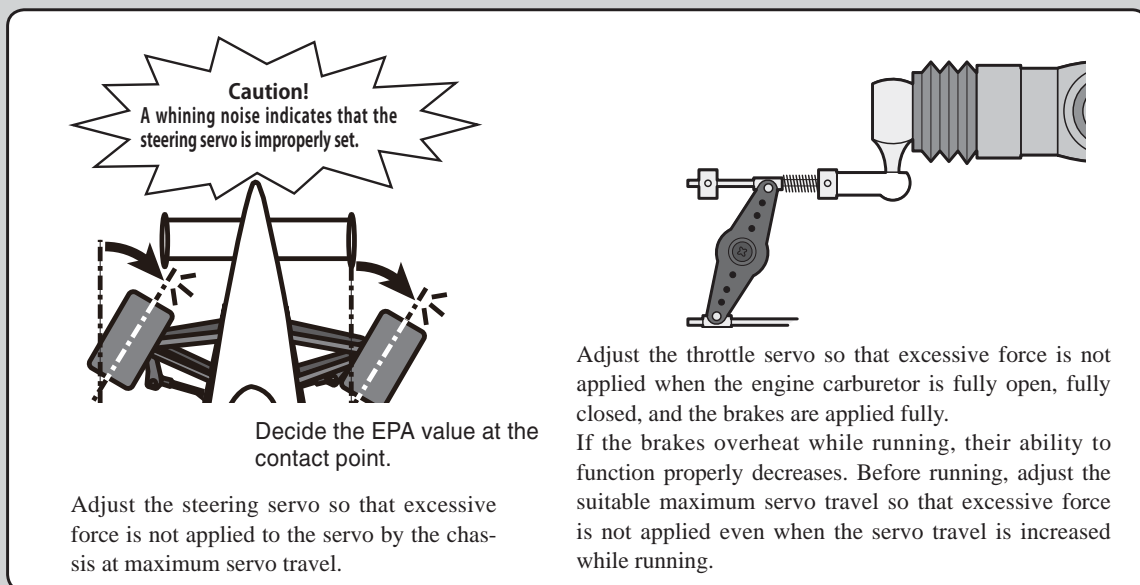

## Warning

### Electronic Speed Control

- ⊘ Install the heat sinks where they will **not** come in contact with aluminum, carbon fiber or other parts that conduct electricity.

If the FET Amp (Electronic speed control) heat sinks touch other materials that conduct electricity a short circuit could occur. This could result in loss of control and damage to the system.

### Motor Noise Suppression

- ❗ Always install capacitors to suppress noise when electric motors are used.

If capacitors are not properly installed you could experience erratic operation and reduced range as well as loss of control.

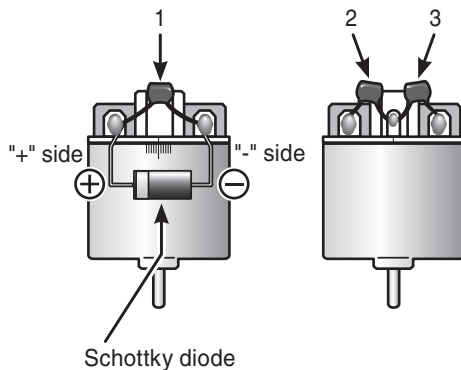

Motors with no suppressor capacitors, or inadequate suppression, may cause the receiver to malfunction. Always solder the capacitors supplied to your motor.

The Schottky diode improves the efficiency of the speed control / motor combination and provides extra protection to the brake FETs. The white ring must always face the positive side.

### Other Noise Suppression Methods

- ❗ Be sure there are no metal parts in your model which under vibration can come in contact with other metal parts.

Metal to metal contacts under vibration will emit a high frequency noise that will affect the receiver's performance. You could experience erratic operation and reduced range as well as loss of control.

## Preparations (Transmitter)

Before setting the Transmitter functions, check set the following items first.

### (Display when power switch turned on)

When the power switch is turned on, the currently selected model number is displayed. Check if this number is the model number you want to set-up. To change the model number, use the Model Select function.

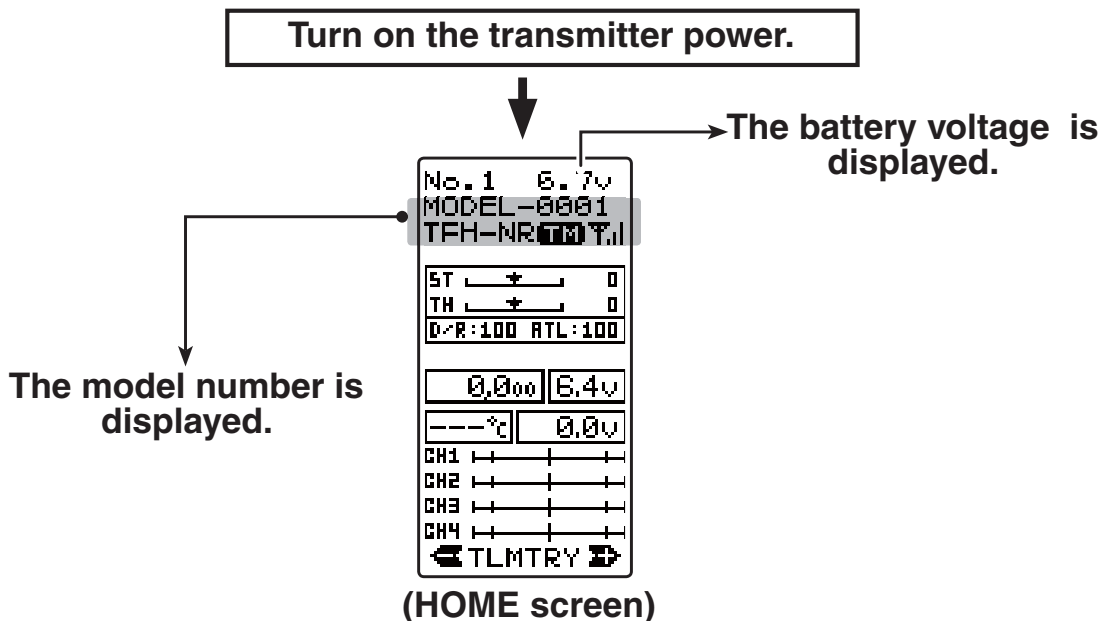

Initial Set-Up

### Receiver Type Check (RX MODE)

This mode sets the RX type of the transmitter to match the receiver and servos used.

The T4GRS transmitter uses the telemetry type T-FHSS ("TFH") system.

It can also use the conventional FHSS and S-FHSS ("SFH") systems. Because the R304SB(-E) receiver supplied with the T4GRS uses the telemetry type T-FHSS ("TFH") system, its RX type must be set to the T-FHSS high speed mode ("TFH-HI") or the T-FHSS normal mode ("TFH-NR"). Never use analog servos when the RX type was set to the T-FHSS ("TFH") 2.4GHZ system high speed mode "TFH-HI" or the S-FHSS (SFH) high speed mode "SFH-HI". The servos may be damaged. For example, if analog servos are used with a telemetry type T-FHSS receiver (R304SB, etc.), the RX type must be set to "TFH-NR", and if analog servos are used with an S-FHSS receiver (R2104GF, R204FG-E, etc.), the RX type must be set to S-FHSS ("SFH-NR") system normal mode or FHSS ("FHSS") system. When using digital servos (including BLS Series brushless servos), any RX type can be used.

When a dedicated FHSS receiver (R603GF/R2004GF) is used, it will not operate if the RX type is not set to "FHSS".

If the receiver used and the RX type settings are different, change the RX type using the "RX MODE" function. Which RX type is set can be checked at the HOME screen.

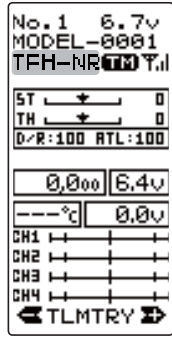

T-FHSS Normal speed  
T-FH (NORM)

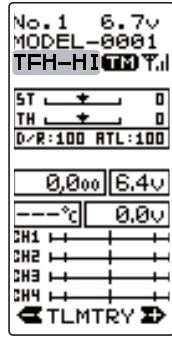

T-FHSS High speed  
T-FH (HIGH)

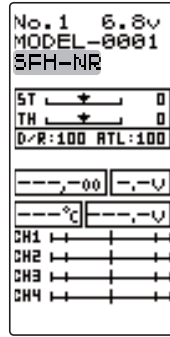

S-FHSS Normal speed  
S-FH (NORM)

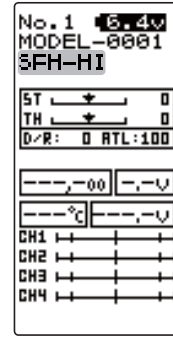

S-FHSS High speed  
S-FH (HIGH)

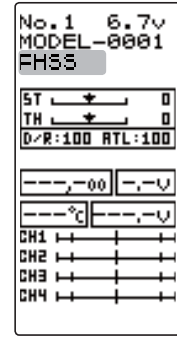

FHSS

## Receiver Type Change & How To Link

The first operation described below sets the RX type. Next, the transmitter and receiver are linked and the transmitter ID number is memorized at the receiver so that signals from other transmitters will not be received. The telemetry type T-FHSS also simultaneously memorizes the ID number of the receiver at the transmitter so that data from other receivers will not be received.

The RX type setting and transmitter and receiver linking methods are described here. Refer to the figure at the right for the edit buttons used.

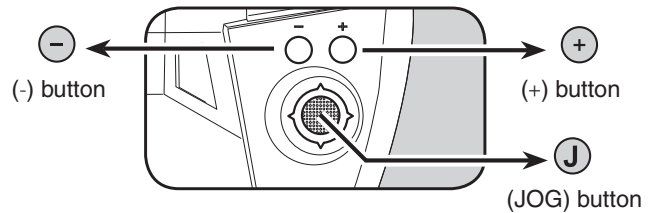

- 1 Set the transmitter power switch to DISP. Select "RX Setting" using (JOG) button up or down operation, and display the "RX MODE" screen by pressing the (JOG) button.

**DOWN**



**DISP**

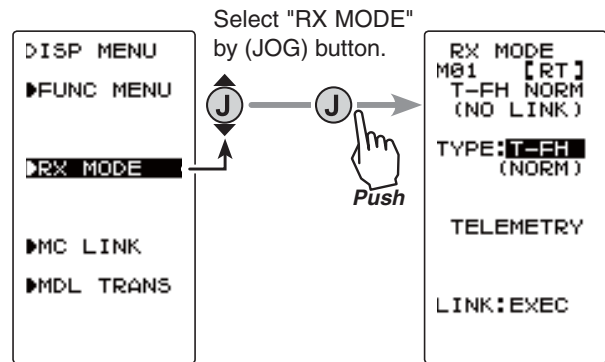

- 2 Move the cursor to "TYPE: ----" using (JOG) button up or down operation, and select the RX type with the (+) button or (-) button.

When the (JOG) button is pressed for approximately 1 second, an electronic sound is generated and setting ends.

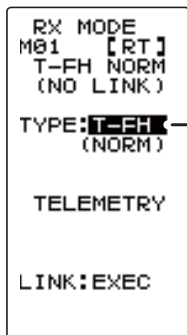

Select TYPE with the (+) or (-) button.



Select RX type with the (+) or (-) button.

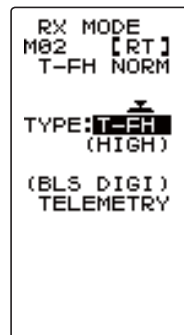

Press the (JOG) buttons continuously for approximately 1 second.



Push

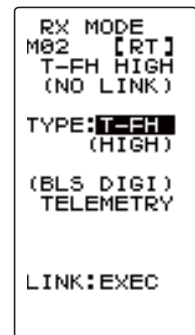

\*When using an FHSS (R603GF/R2004F, etc.) or S-FHSS(SFH) system (R2104GF, R204GF-E, etc.) receiver, after the end of setting up to here set the transmitter power switch to OFF and go to "**Receivers other than T-FHSS**".

**3** Bring the transmitter and receiver to within 50cm of each other (do not allow the antennae to touch) and turn on the receiver power.

**4** Move the cursor to "LINK: EXE" by (JOG) button up or down operation.

When the (JOG) button is pressed for approximately 1 second, "PUSH RX LINK SW" appears on the screen and 20 seconds countdown begins. Countdown can be cancelled at any time using button up down or left right operation.

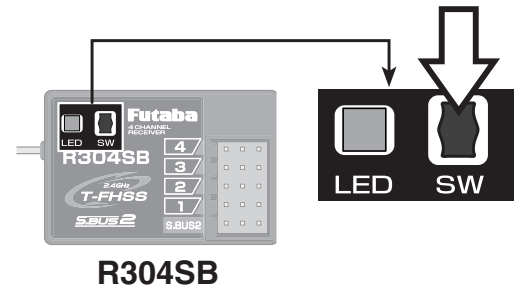
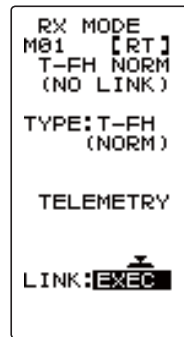

**5** During 20 seconds countdown, press the receiver link switch for approximately 2 seconds. The LED will begin to blink red. After the receiver LED switches from blinking red to green-red steady light, the T4GRS generates an electronic beeping sound, and "LINK:OK" and "COMPLETE!" appear on the screen, reading of the mutual IDs ends and the memorized receiver ID number appears on the T4GRS screen. If an error screen was displayed, linking failed. Retry linking. If the transmitter and receiver are linked normally, set the power switch to the OFF position and then return it to the PWR ON position. If the receiver LED lights green, linking was successful. Check for correct servo operation.

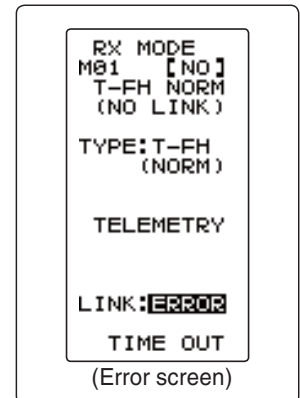
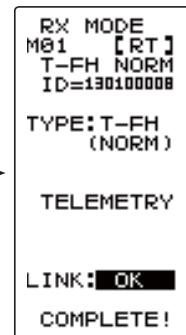
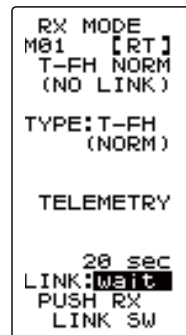

Initial Set-Up

\*The T4GRS and a telemetry type T-FHSS receiver (R304SB, etc.) mutually memorize the combined ID linked last at each model memory.

Since the T4GRS can memorize only 1 receiver ID at each model memory, multiple T-FHSS receivers cannot be used with the same model memory. If the same model memory is used for more than one model it will be necessary to re-link the receiver's each time a different model is operated.

When using multiple telemetry type T-FHSS receivers, link and combine them with each T4GRS model memory.

Note however that, multiple receivers cannot be linked to multiple model memories.

The telemetry function communications status can be checked at the T4GRS HOME screen.

The telemetry ON/OFF and communication status can be checked at the HOME screen.

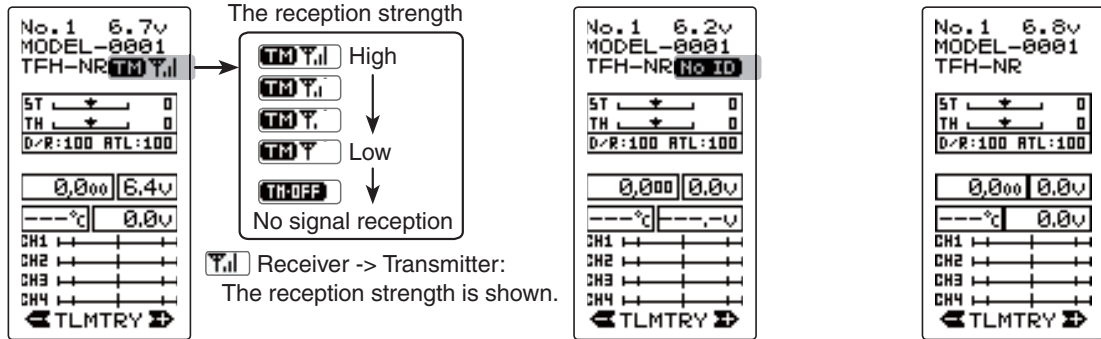

- Telemetry function :ON
- Receiver ID setting complete
- Data receiving sensitivity display
- **T.M OFF** shows that data cannot be received because it is outside the data receiving range or because of the effects of an obstruction or the receiver power is OFF after receiver ID check.
- Telemetry function :ON
- Receiver ID before setting or ID mismatch
- When the receiver ID is set, before ID check in the receiver power OFF state.
- Telemetry function :OFF

## Receivers Other Than T-FHSS

- 1 Bring the transmitter and the receiver close to each other, within 20 inches (half meter).
- 2 Turn on the transmitter.
- 3 Turn on the receiver.
- 4 Push the link switch of the receiver.  
When the link is complete, the LED in the receiver changes to solid green.

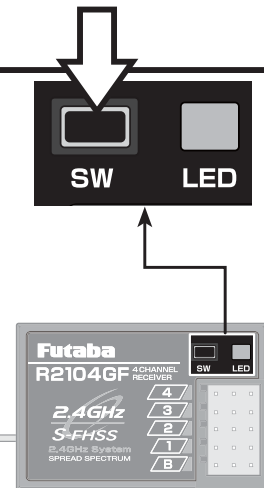
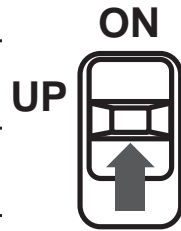

### Precaution:

If there are many Futaba 2.4GHz systems (T-FHSS/ S-FHSS/ FHSS) turned on in close proximity to your receiver then it might not link to your transmitter. In this case, even if the receiver's LED stays solid green, unfortunately the receiver might have established a link to one of other transmitters. This is very dangerous if you do not notice this situation. In order to avoid the problem, we strongly recommend you to double-check whether your receiver is really under control by your transmitter by giving the stick input and then checking the servo response.

\*Please refer to the table below for LED status vs receiver's condition.

LED status vs receiver's condition:

No signal reception	Red : On
Receiving signals	Green: On
Receiving signals, but ID is unmatched.	Green: Blink *1 (T-FHSS ,Red : On)
Unrecoverable failure (EEPROM,etc.)	LED: Red and Green turn on alternately

\*1: LED could be change to red intermittently during data processing.

## Warning

⚠ After the linking is done, please cycle receiver power and check if the receiver to be linked is really under the control of your transmitter.

⚠ Do not perform the linking procedure with the drive motor connected or the engine operating as it may result in serious injury.

# Throttle Mode Check

\*This function is not available in "TH-STK : F10 mode".

The throttle servo travel can be set to 5:5 or 7:3 for throttle stick operation as required by the throttle mode function .

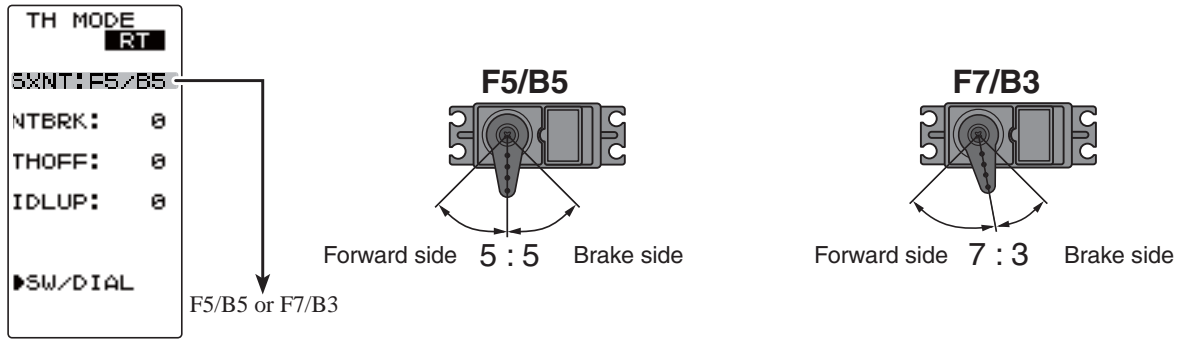

# Trims Initial Set-Up

## - Steering trim (DT1) check

On the initial set-up, steering trim is assigned to the DT1 trim lever. Operate the lever and make sure the marker moves on the ST graph. If default has been changed, test steering trim in its new location. After checking the trim, set the trim display to the center (N) position.

## - Throttle trim (DT2) check

On the initial set-up, throttle trim is assigned to the DT2 trim lever. Operate the lever and make sure the marker moves on the TH graph. If the default has been changed, test the throttle trim in its new location. After checking the trim, set the trim display to the center (N) position.

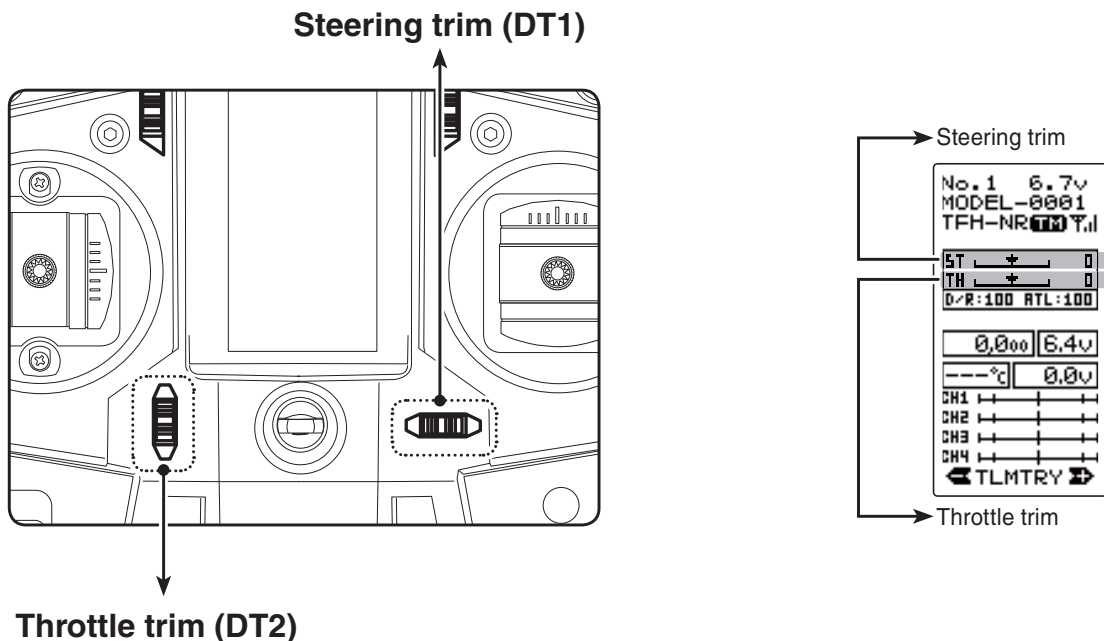

Initial Set-Up

### - Steering dual rate (DT3) check

At initial set-up, steering dual rate (D/R) is assigned to the DT3. Operate the lever and check if the D/R value displayed on the screen changes. After checking D/R, set the steering dual rate to 100%.

### - Throttle ATL (DT4) check

At initial setting, throttle ATL (ATL) is assigned to the DT4. Operate the lever and check if the ATL value displayed on the screen changes. After checking ATL, set throttle ATL to 100%.

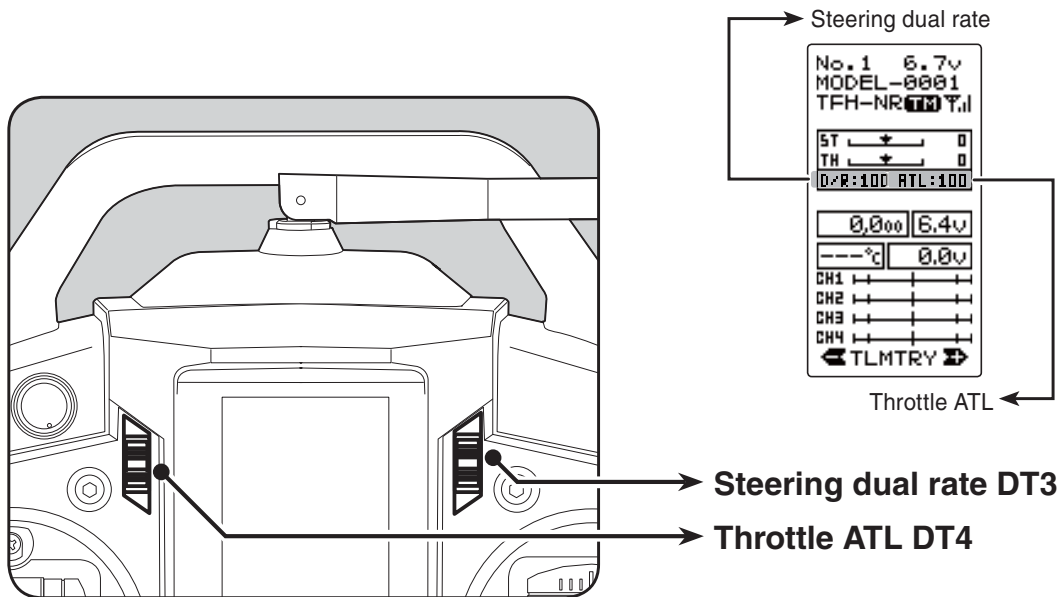

### (Set-Up Procedure When Installed In a Car)

When installing the servos in a car, performing function set-up in the following order is recommended.

- 1** Carry out the Trims Initial Set-up as described on the previous page.
- 2** Set the servo direction of operation using the Reverse function.
  - The servo installation method and linkage direction depend on the kit. Therefore, the servo operation direction may have to be reversed relative to transmitter operation. Before installing the servo, check the operating direction and set it using the Reverse function.
- 3** Set the subtrim and adjust the servo neutral point.
- 4** Set the throttle stick travel by adjusting the throttle stick mechanical ATL to your liking.
  - When the throttle stick travel is changed, set the servo travel as required using the adjuster function.
- 5** Set EPA of each channel and adjust the servo throw (travel).



## Operation Of Screen

In this instruction manual, Edit Buttons are represented by the symbols shown below. The (JOG) button can be operated in the 4 directions up, down, left, and right.

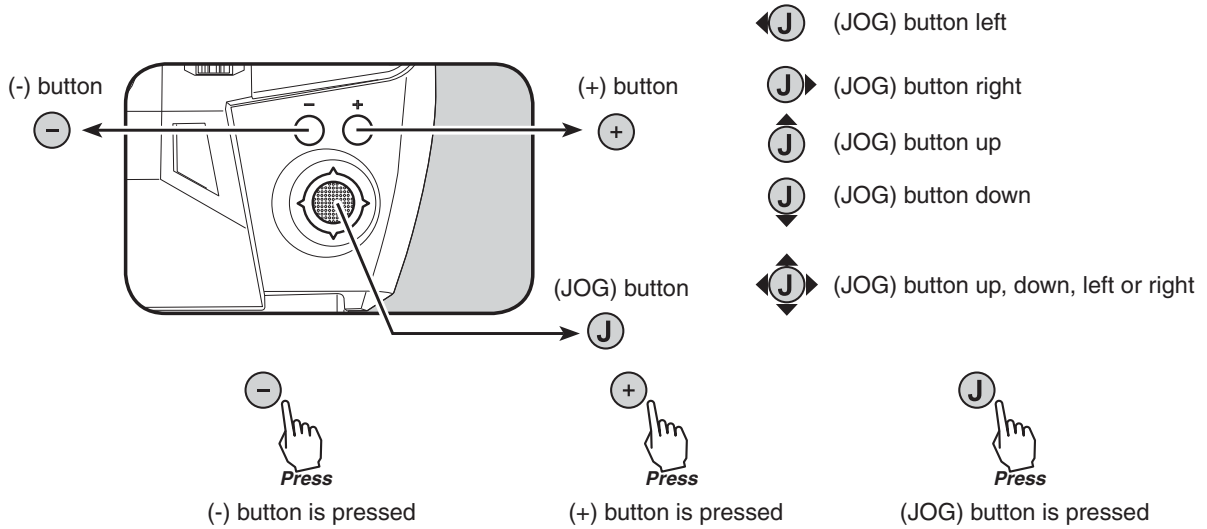

## Selecting The Menu Screen

Refer to the map below for the method of displaying the function setting menu screen from the PWR ON initial screen or DISP (display) screen and the method of returning from the menu screen to the PWR ON initial screen or DISP (display) screen.

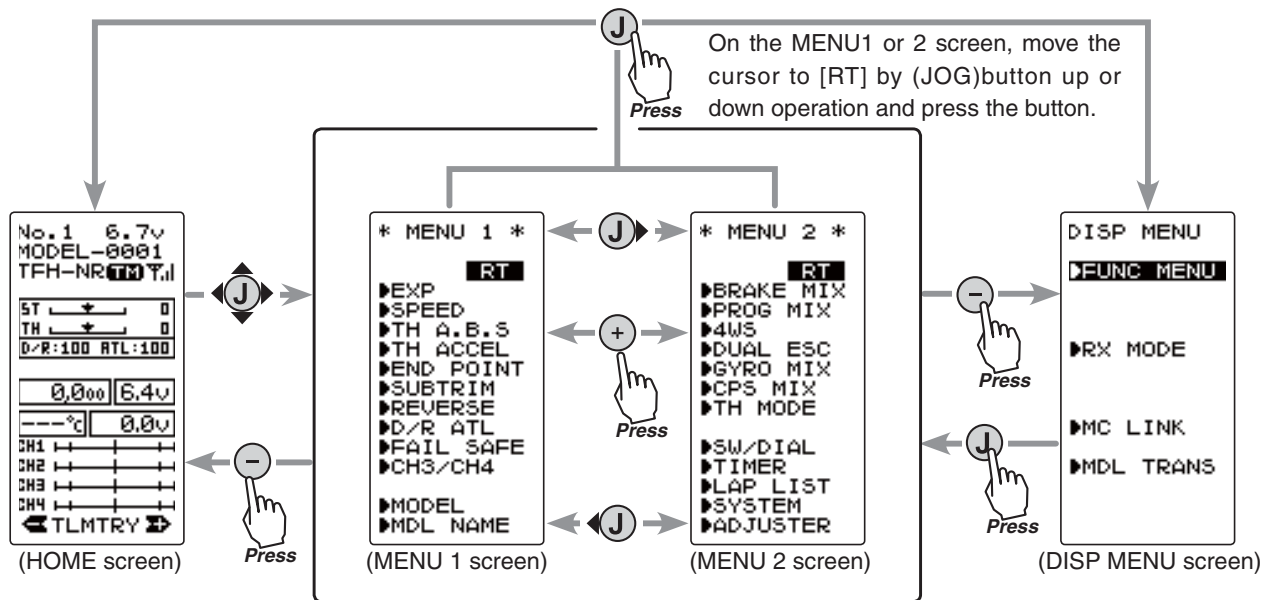

On the DISP MENU screen, move the cursor to "FUNC MENU" by (JOG) button up or down operation and press the button.

## Selecting Items On The Menu Screen

The item indicated by the highlighted cursor on the screen is selected.

The cursor is moved using the (JOG) button in up or down movements. The cursor movement figure shown below is an example of the MENU 1 screen. However, movement of the cursor is the same in all of the screens.

For instance, if the (JOG) button is pressed when the cursor is at the end point (EPA) on the MENU 1 screen, the end point (END POINT) function setting screen appears.

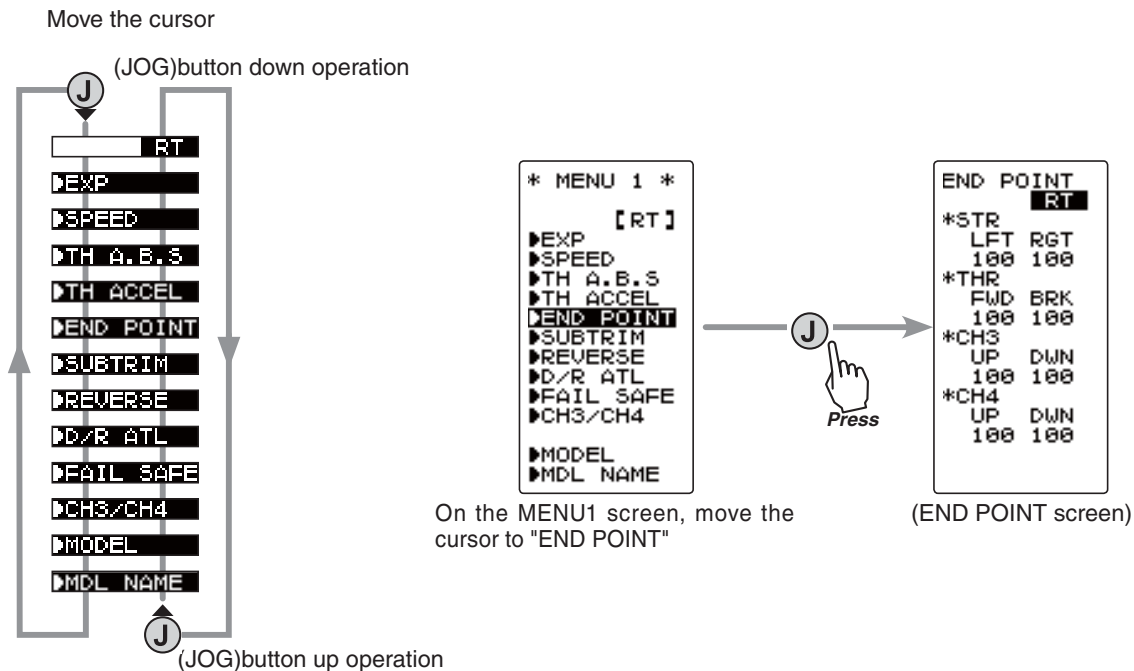

## Value Of Each Function And Changing The Set Value

Values, settings, and other data on all the function setting screens are changed with the (+) and (-) buttons.

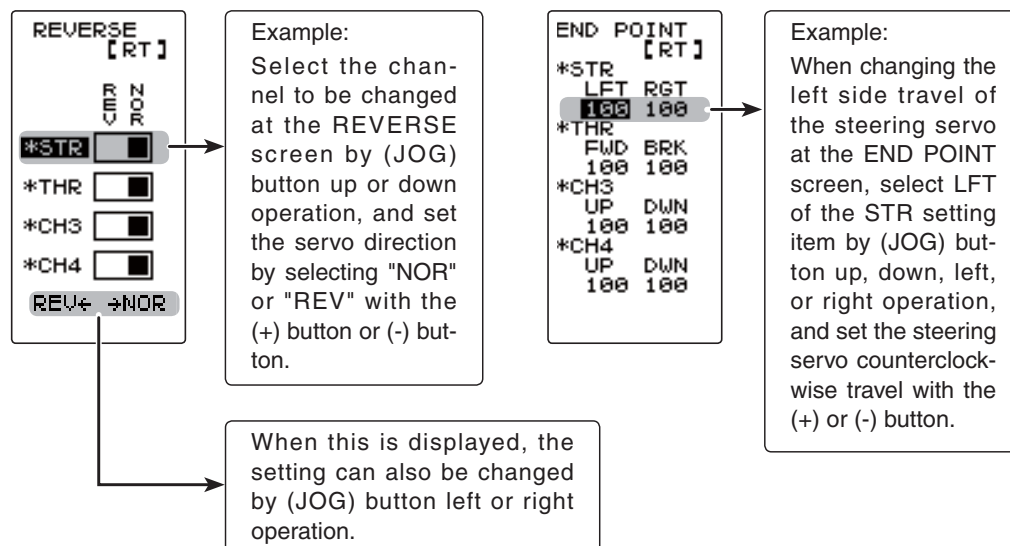

# Basic Menu Japanese Katakana Character Display

On the system menu, the basic menu screen shown below can be displayed in Japanese katakana characters.

"KATAKANA" characters	Alphabetic characters
EXP	EXP
スピード	SPEED
TH A.B.S	TH A.B.S
アクセレーション	TH ACCEL
エンドポイント	END POINT
トリム	TRIM
リバース	REVERSE
D/R ATL	D/R ATL
フェイルセーフ	FAIL SFE
CH3 /CH4	CH3 /CH4
モデル	MODEL
モデル ネーム	MDL NAME
ブレーキ MIX	BRAKE MIX
PROG MIX	PROG MIX
4WS	4WS
デュアルESC	DUAL ESC
ジャイロ MIX	GYRO MIX
CPS MIX	CPS MIX
TH モード	TH MODE
SW/ダイヤル	SW/DIAL
タイマー	TIMER
ラップリスト	LAP LIST
システム	SYSTEM
アジャスター	ADJUSTER

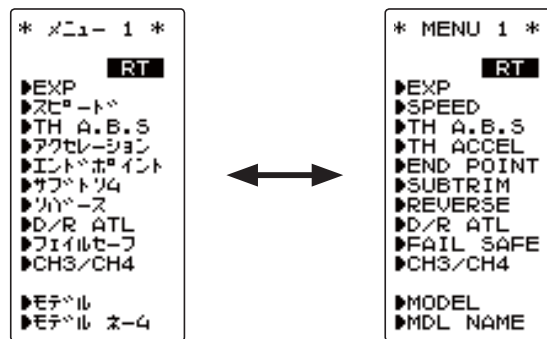

(MENU 1 screen)

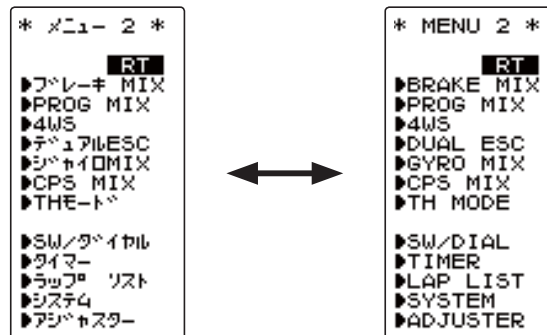

(MENU 2 screen)

## Changing the character

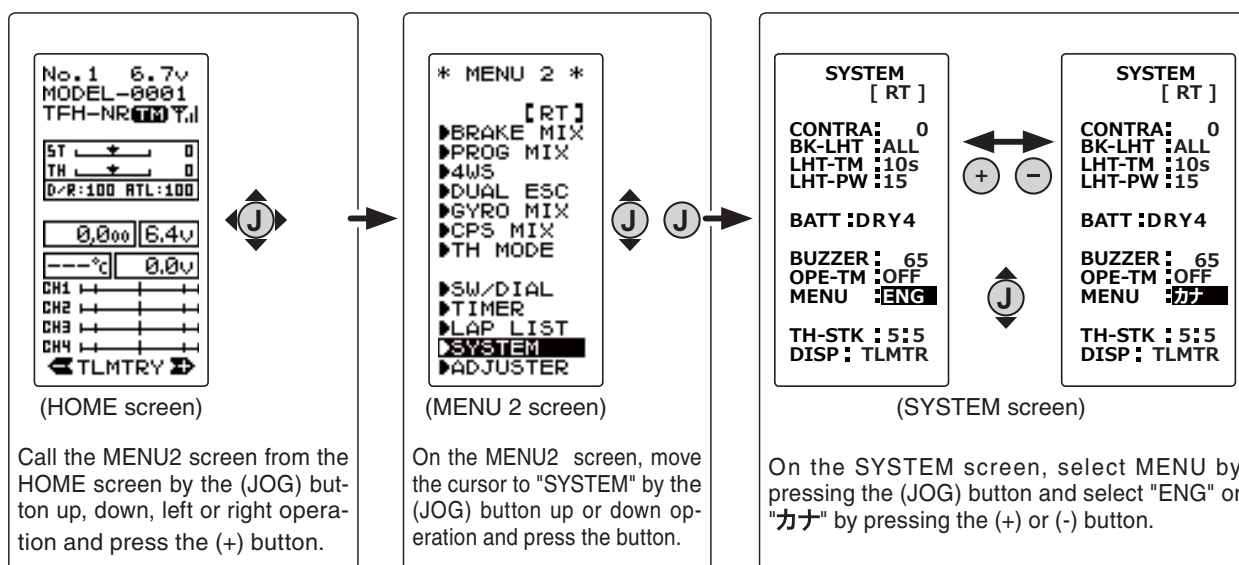

## Function List

Function Abbreviation	Description Of Function	Page No
<b>RX MODE</b>	Receiver type selection/linking with telemetry type T-FHSS system receiver	P-37
<b>MODEL</b>	Model memory select/ Model memory copy/ Model memory reset	P-47
<b>MDL NAME</b>	Model memory name set/modify, username set/modify	P-50
<b>REVERSE</b>	Servo reversing	P-52
<b>SUBTRIM</b>	Servo center position fine adjustment	P-53
<b>END POINT</b>	End point adjustment	P-54
<b>FAIL SAFE</b>	Fail safe, battery fail safe	P-57
<b>EXP</b>	Steering curve adjustment/ Throttle curve adjustment	P-59
<b>SPEED</b>	Steering servo delay/ Throttle servo delay	P-62
<b>TH ACCEL</b>	Reduces the "lag time" of the throttle from the neutral position.	P-65
<b>TH A.B.S</b>	Pulsing brake	P-67
<b>CH3/CH4</b>	Channel 3&4 servos operation position set/check	P-71
<b>D/R ATL</b>	Steering angle adjustment while running/ Brake side adjustment	P-72
<b>SW/DIAL</b>	Selection of functions operated by switch, digital dial and digital trim	P-73
<b>BRAKE MIX</b>	Front and rear independent brake control for 1/5GP car, etc.	P-76
<b>PROG MIX</b>	Programmable mixing between specific channels	P-78
<b>4WS MIX</b>	4WS mixing	P-80
<b>DUAL ESC</b>	Front and rear ESCs mixing	P-82
<b>GYRO ESC</b>	The sensitivity of Futaba car rate gyros can be adjusted.	P-84
<b>CPS ESC</b>	The CPS-1 of Futaba LED controller can be adjusted.	P-86
<b>TH MODE</b>	Throttle servo forward side and brake side operation rate setting/ Neutral brake/ Idle up at engine start/ engine cut off by switch	P-88
<b>MC LINK</b>	MC851C/602C/402CR/950CR/940CR/960CR Link software setting function	P-92
<b>MDL TRANS</b>	Data copy from T4GRS to another T4GRS	P-100
<b>TIMER</b>	Up, down, or lap timer	P-102
<b>LAP LIST</b>	Lap timer data (lap time, total time) check	P-108
<b>SYSTEM</b>	LCD contrast/backlight/Battery type/buzzer/power left "ON" alarm/Basic menu character display /Throttle stick adjustment/HOME screen display mode	P-109
<b>ADJUSTR</b>	Steering stick and throttle stick correction	P-113
<b>TELEMETRY</b>	Displays the status during operation, of each sensor unit and records the status in a data log.	P-115

## Model "MODEL"

Forty model data (data for 40 R/C cars) can be saved in the T4GRS transmitter. This menu selects the model, copies data between models.

### Model Menu Display

The MENU 1 screen is displayed using (JOG) button up, down, left, or right operation at the HOME screen.

The display can be switched to the MODEL screen by selecting "MODEL" and using (JOG) button up or down operation.

The display can be switched to the HOME screen by switching from the MODEL menu screen to the MENU 1 screen by pressing the (JOG) button and then pressing the (-) button at the MENU 1 screen.

When the (JOG) button is pressed from the MODEL menu screen, the display switches to the MENU1 screen and can then be switched to the HOME screen by pressing the (-) button from the MENU1 screen.

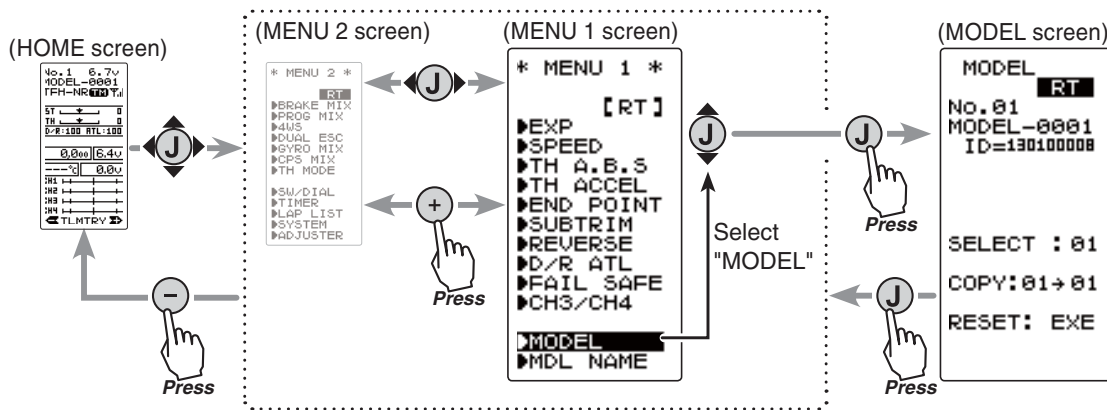

- Setting item**
- SELECT :Model selection
  - COPY :Model copy
  - RESET :Model reset

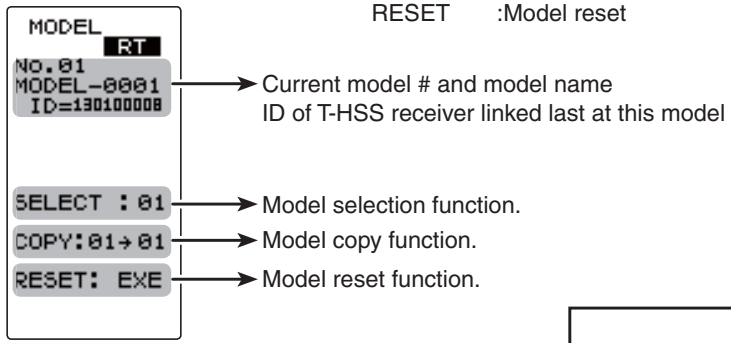

When a T-FHSS receiver is not linked with a model whose RX type is set to T-FHSS, (NO LINK) is displayed.  
When RX type is set to S-FHSS or FHSS other than T-FHSS, nothing is displayed here

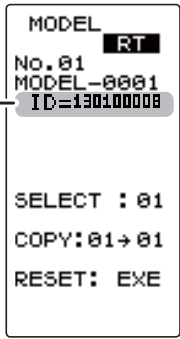

Function

# Model Selection "SELECT"

Forty model data (model data for 40 R/C cars) can be saved in the 4GRS transmitter and used when the relevant model data is called.

## Using the model select function

- Display the MODEL screen.

- 1 (Selection of model select)  
Move the cursor to "SELECT" using the (JOG) button up or down operation.

```
MODEL [RT]
No. 01
MODEL-0001
ID=130100008

SELECT : 01
COPY: 01 → 01
RESET: EXE
```

→ Move the cursor to select model # with the (JOG) button.

- 2 (Model #. selection)  
Select the model number with the (+) or (-) button. "01" ~ "40" are displayed.

```
MODEL [RT]
No. 01
MODEL-0001
ID=130100008

MODEL-0002
(NO LINK)

SELECT : 02
COPY: 01 → 01
RESET: EXE
```

Model #.  
01~40

→ Select model # with the (+) or (-) button.

- 3 (Model select execution)  
Press the (JOG) button continuously for 1 second. A beeping sound is generated and the model is selected.

```
MODEL [RT]
No. 02
MODEL-0002
(NO LINK)

SELECT : 02
COPY: 02 → 02
RESET: EXE

COMPLETE!
```

→ Modified model # and model name

→ "COMPLETE!" is displayed.

- Model change is complete when the model No. and model name on the screen change and "COMPLETE!" is displayed .

- 4 When completed, move the cursor to [RT] by the (JOG) button, and return to the MENU1 screen by pressing the (JOG) button.

```
* MENU 1 *
[RT]
▶EXP
▶SPEED
▶TH A.B.S
▶TH ACCEL
▶END POINT
▶SUBTRIM
▶REVERSE
▶D/R ATL
▶FAIL SAFE
▶CH3/CH4

▶MODEL
▶MDL NAME
```

When the model is changed, switch the transmitter "OFF" and then "ON" before operation.

Function

# Model Copy "COPY"

The contents of the currently selected model data can be copied to another model.

## Using the model copy function

- Display the MODEL screen.

- 1 (Selection of model copy)  
Move the cursor to "COPY" using the (JOG) button up or down operation.

```
MODEL [RT]
No. 01
MODEL-0001
ID=130100008

SELECT : 01
COPY: 01→01
RESET: EXE
```

Move the cursor to "COPY" with the (JOG) button.

- 2 (Model #. selection)  
Select the copy destination model number with the (+) or (-) button. "01" ~ "40" are displayed.

```
MODEL [RT]
No. 01
MODEL-0001
ID=130100008

MODEL-0002

SELECT : 01
COPY: 01→02
RESET: EXE
```

Model #.  
01~40

The copy destination model # with the (+) or (-) button.

- 3 (Model copy execution)  
Press the (JOG) button for about 1 second. A beeping sound is generated and the model is selected.

```
MODEL [RT]
No. 01
MODEL-0001
ID=130100008

MODEL-0001

SELECT : 01
COPY: 01→02
RESET: EXE

COMPLETE!
```

Model name is also copied.

"COMPLETE!" is displayed.

-Copying is complete when "COMPLETE!" is displayed on the screen.

- 4 When completed, move the cursor to [RT] by the (JOG) button, and return to the MENU1 screen by pressing the (JOG) button.

```
* MENU 1 *
[RT]
▶EXP
▶SPEED
▶TH A.B.S
▶TH ACCEL
▶END POINT
▶SUBTRIM
▶REVERSE
▶D/R ATL
▶FAIL SAFE
▶CH3/CH4
▶MODEL
▶MDL NAME
```

Function

## Model Reset "RESET"

This function resets and initializes the contents of the currently selected model data.

However, the adjuster function (ADJUSTER), system setting (SYSTEM), and type of receiver mode (TYPE) are not initialized.

### Using the model reset function

- Display the MODEL screen.

- 1** (Selection of model reset)  
Move the cursor to "RESET" using the (JOG) button up or down operation.

```
MODEL [RT]
No. 01
MODEL-0001
ID=130100008

SELECT : 01
COPY: 01 → 01
RESET: EXE
```

Move the cursor to "RESET" with the (JOG) button.

- 2** (Model reset execution)  
Press the (JOG) button for about 1 second. A beeping sound is generated and the model is selected.

-Resetting is complete when "COMPLETE!" is displayed on the screen.

```
MODEL [RT]
No. 01
MODEL-0001
ID=130100008

SELECT : 01
COPY: 01 → 01
RESET: EXE
COMPLETE!
```

"COMPLETE!" is displayed.

- 3** When completed, move the cursor to [RT] by the (JOG) button, and return to the MENU1 screen by pressing the (JOG) button.

```
* MENU 1 *
[RT]
▶EXP
▶SPEED
▶TH A.B.S
▶TH ACCEL
▶END POINT
▶SUBTRIM
▶REVERSE
▶D/R ATL
▶FAIL SAFE
▶CH3/CH4

▶MODEL
▶MDL NAME
```

The set RX type and T-FHSS receiver ID remain even if the model is reset. The same receiver can be used as is without re-linking



# Model Name "MDL NAME"

This function allows you to assign a ten character name to each model memory and user name.

Display to "MDL NAME" screen by the following method:

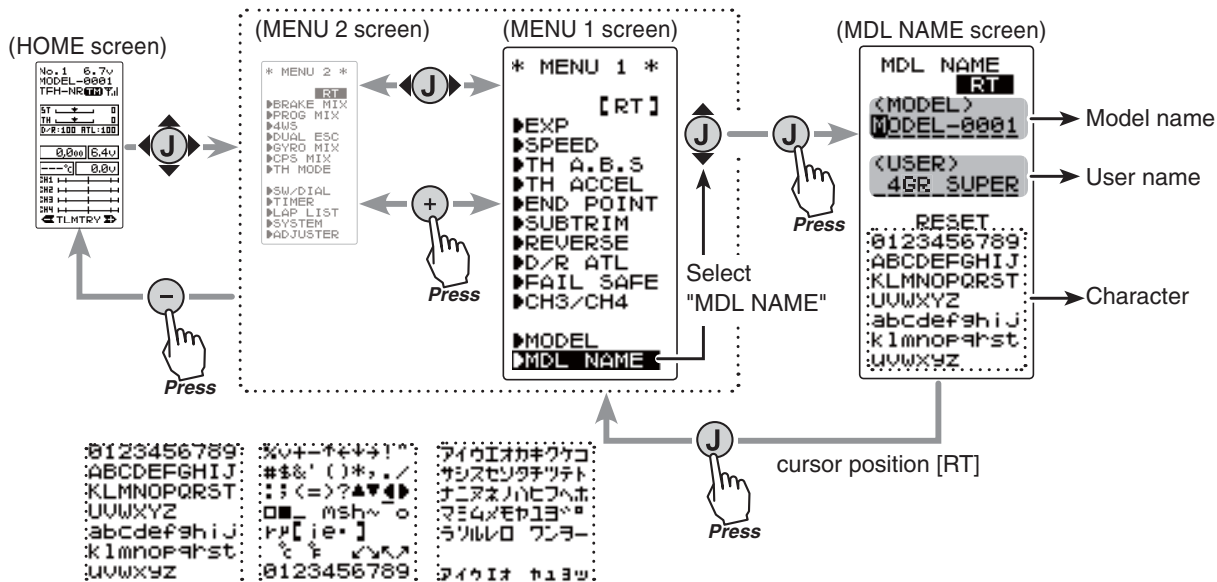

When (JOG) button left or right operation is performed from both the left and right ends of the character list, the page (all 3 pages) is changed and the character set is selected.

(KATAKANA of the 3rd page is displayed when "KANJI" is set by the "SYSTEM" function "MENU".)

## Setting the model name and user name

- 1** (Move the cursor to the character you want to change.)

Select the model name character you want to set or change by moving the cursor using the (+) or (-) button. The selected character blinks.
- 2** (Selecting the character to be used)

Select the character to be used from the character list at the lower section of the screen using the (JOG) button up, down, left, or right operation. The selected character blinks. After selecting the character to be used, press the (JOG) button. The character is entered and the model name or user name character row moves to the right. To clear the model or user name move the cursor to "RESET" using the (JOG) button up, down, left, or right operation, and press the button for about 1 second. A beeping sound is generated and the model name is initialized to the factory setting.
- 3** When completed, move the cursor to [RT] using the (JOG) button, and return to the MENU1 screen by pressing the (JOG) button.

Move the cursor to the character you want to change by (+) or (-) button.

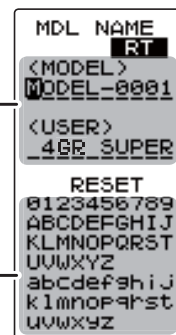

Select the character by (JOG) button.

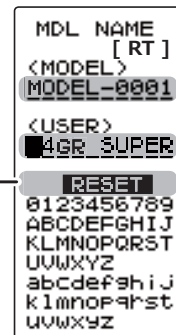

Move the cursor to "RESET" by the (JOG) button up or down operation.

Function

# Servo Reverse "REVERSE"

(All channel)

This function reverses the direction of operation of the servos related to transmitter steering, throttle, and channel 3 /4 operation.

However, when the position set by trim or subtrim shifts from the center, the center becomes the opposite side.

Display to "REVERSE" screen by the following method:

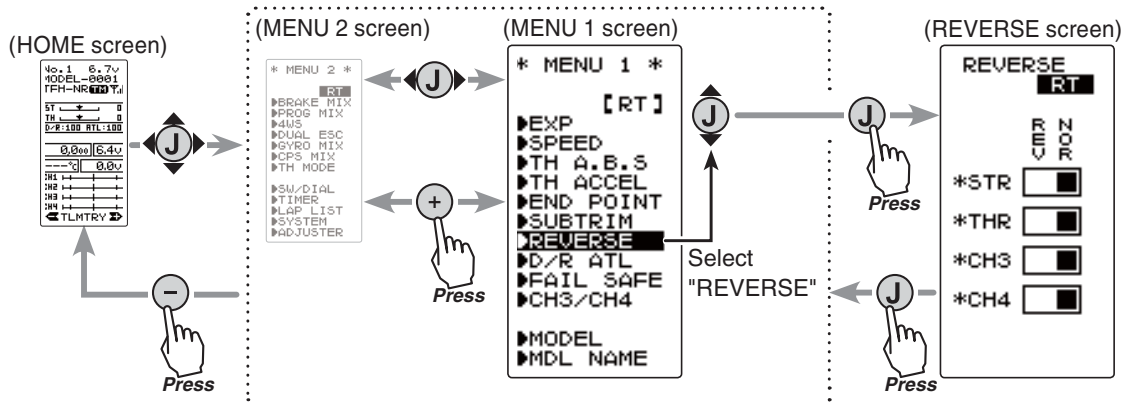

### Setting item

- STR :Steering (1st channel)
- THR :Throttle (2nd channel)
- CH3 :3rd channel
- CH4 :4th channel

## Servo Reverse Function Setting

(Preparation)

- Select the channel to be set using the (JOG) button up or down operation.

### 1 (Servo reverse setting)

Use the (+) or (-) button to reverse the servo operation direction.

NOR/REV can also be set using (JOG) button left or right operation

(Each channel can be set similarly.)

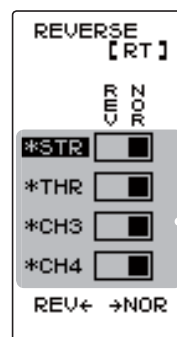

Move the cursor to "STR, THR, CH3 and CH4" with the (JOG) button.

### Select button

- Select with the (+) or (-) buttons.

**2** When completed, move the cursor to [RT] using the (JOG) button, and return to the MENU1 screen by pressing the (JOG) button.

# Subtrim "SUBTRIM"

(All channel)

Use this function to adjust the neutral position of the steering, throttle, channel 3 and channel 4 servos.

\*Subtrim adjusts the entire range of the servo in the set direction.

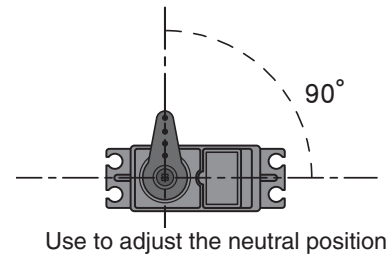
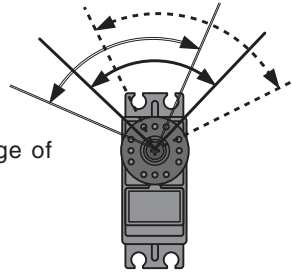

Use to adjust the neutral position

Display to "REVERSE" screen by the following method:

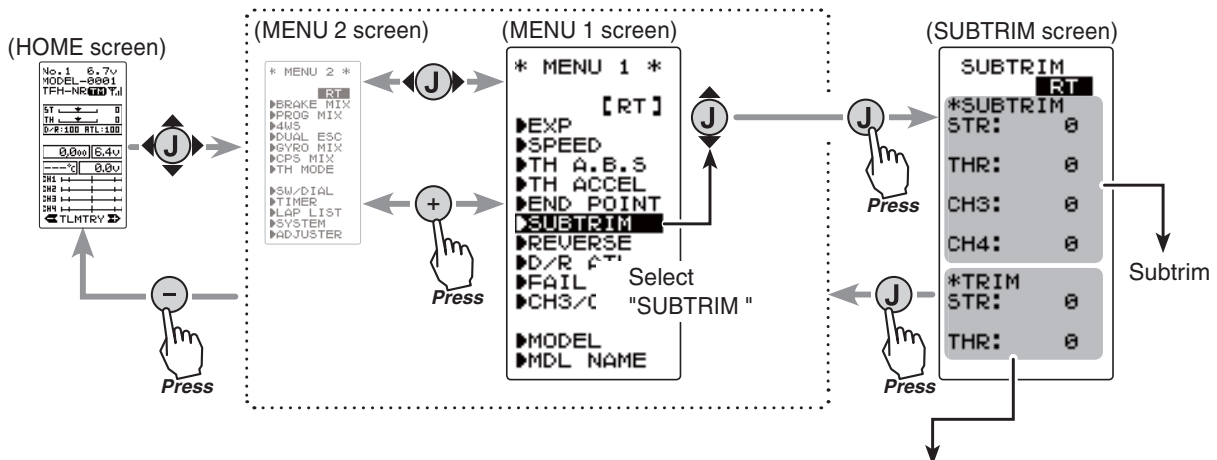

**Steering and throttle center trim**  
When assigning DT1, DT2, or other digital trimming to another function, make adjustments at this screen.

## Subtrim adjustment

(Preparation)

- Set the steering and throttle digital trims to the neutral "0" position. Set CH3 and CH4 to the center "0" position.

### Setting item

- STR :Steering (1st channel)
- THR :Throttle (2nd channel)
- CH3 :3rd channel
- CH4 :4th channel

### 1 (Subtrim adjustment)

Use the (+) or (-) button to adjust the center.  
(Each channel can be set similarly.)

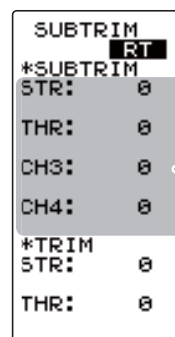

Move the cursor to "STR, THR, CH3 and CH4" with the (JOG) button.

### Adjust button

- Adjust with the (+) and (-) buttons.
- Return to the initial value "0" by pressing the (+) and (-) buttons simultaneously for about 1 second.

### Subtrim

- ST :L100~R100
- TH :B100~F100
- CH3 :-100~+100
- CH4 :-100~+100
- Initial value : 0

### 2

When completed, move the cursor to [RT] by the (JOG) button, and return to the MENU1 screen by pressing the (JOG) button.

Function

# End Point Adjuster "END POINT" (EPA)

(All channel)

Use this when performing left and right end point adjustments, throttle high side/brake side operation amount adjustment, channel 3 and channel 4 servo up side/down side operation amount adjustment during linkage.

- Correct the maximum steering angle for left and right steering angles when there is a difference in the turning radius due to the characteristics, etc. of the vehicle.

## Maximum steering angle

The EPA function basically determines the maximum steering angle of each channel. The functions shown below may have been adjusted or the operating range set by EPA function may be exceeded. Check the linkage each time the following functions are adjusted.

- Sub trim (all channels) ..... P53
- Program mixing slave side (all channels) ..... P78
- Idle up (throttle) ..... P89
- Throttle off, Engine cut (throttle)..... P91
- Throttle acceration (throttle) ..... P65

## ATL trim

ATL trim allows adjustment of the brake side operation amount during operation. Therefore, when the operating angle is adjusted with throttle EPA, ATL trim must also be taken into account.

### Warning

- ❗ Operate each servo over its full stroke and be sure the linkage does not bind or is not loose.  
The continuous application of excessive force to a servo may cause damage and excessive battery drain.



Decide the EPA value at the contact point.

Adjust the steering servo so that excessive force is not applied to the servo by the chassis at maximum servo travel.

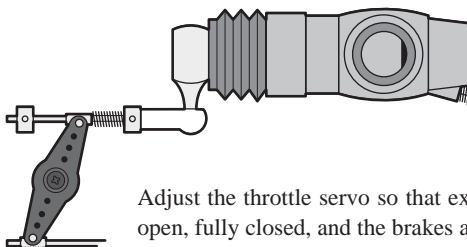

Adjust the throttle servo so that excessive force is not applied when the engine carburetor is fully open, fully closed, and the brakes are applied fully.

If the brakes overheat while running, their ability to function properly decreases. Before running, adjust the suitable maximum servo travel so that excessive force is not applied even when the servo travel is increased while running.

Function

Display to "END POINT" screen by the following method:

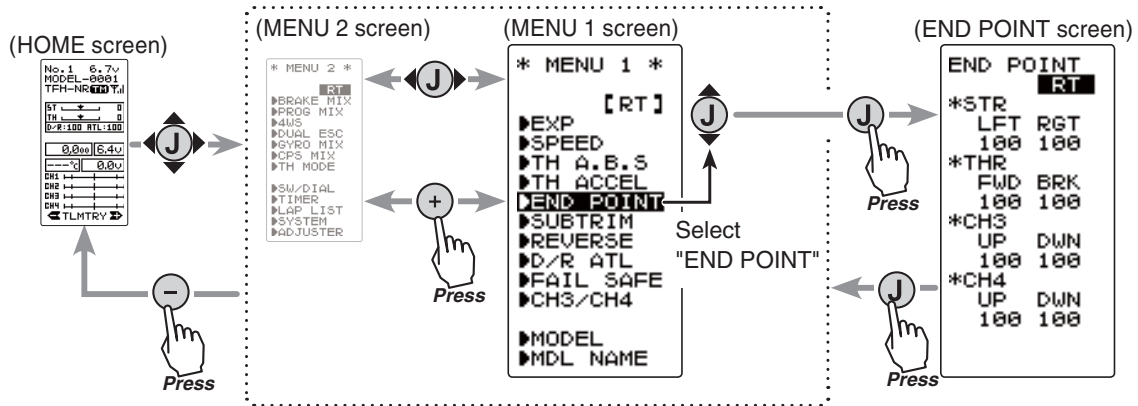

**Setting item selection**

**(Steering and Throttle direction)**

- The direction (STR LFT and STR RGT) linked with the steering stick is switched.
- The direction (THR FWD and THR BRK) linked with the throttle stick is switched.

**Setting item (channel and direction)**

- STR LFT :Steering (left side)
- STR RGT :Steering (right side)
- THR FWD :Throttle (forward side)
- THR BRK :Throttle (brake side)
- CH3/CH4 UP :3rd or 4th channel (up side)
- CH3/CH4 DWN :3rd or 4th channel (down side)

**Steering (END POINT) adjustment**

**(Preparation)**

- Before setup of the steering end point adjustment (END POINT), set the steering D/R lever (initial setup: DT3) to the maximum steering angle position 100%.
- Select the setting item "RGT" using the (JOG) button up, down, left, or right operation and make the following adjustments:

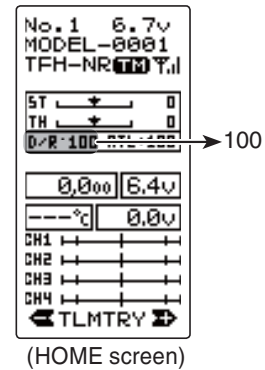

**1 Steering (left side) adjustment**

Move the steering stick fully to the left and use the (+) or (-) buttons to adjust the steering angle.

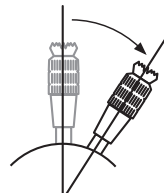

**2 Steering (right side) adjustment**

Move the steering stick fully to the right and use the (+) or (-) buttons to adjust the steering angle.

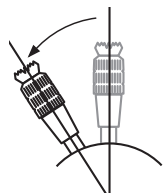

**3** When complete, return to the MENU1 screen by pressing the (JOG) button.

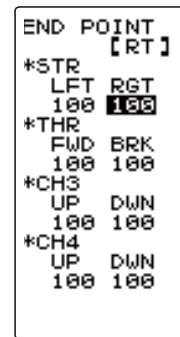

**Adjust button**

- Adjust with the (+) and (-) buttons.
- Return to the initial value "100" by pressing the (+) and (-) buttons simultaneously for about 1 second.

**Steering EPA**

- STR LFT :0~120
- STR RGT :0~120
- Initial value :100

**Function**

## Throttle (END POINT) adjustment

(Preparation)

- Before setting the throttle end point adjustment (END POINT), set the throttle ATL (initial setup: DT4) to the maximum throttle angle position 100%.
- Select the setting item "FWD" by the (JOG) button up or down operation and make the following adjustments:

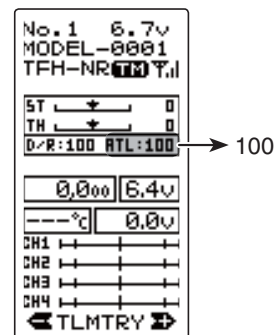

(HOME screen)

### 1 Throttle (full power) adjustment

Push the throttle stick forward to the full power position and use the (+) or (-) buttons to adjust the throttle angle. However, when using an FET amp, set to 100%.

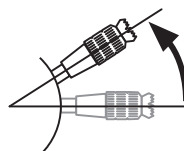

### 2 Throttle (brake side/reverse side) adjustment

Pull the throttle stick full back to brake/reverse and use the (+) or (-) buttons to adjust the throttle angle. However, when using an ESC, set to 100%.

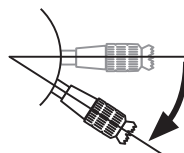

\*This function cannot be used with "TH-STK : F10".

### 3 When completed, return to the MENU1 screen by pressing the (JOG) button.

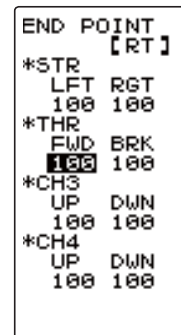

#### Adjust button

- Use the (+) and (-) buttons to make adjustments.
- Return to the initial value "100" by pressing the (+) and (-) buttons simultaneously for about 1 second.

#### Throttle EPA

THR FWD :0~120  
 THR BRK :0~120  
 Initial value :100

## 3rd & 4th channel servo (END POINT) adjustment

### 1 3rd/4th channel servo (up position) adjustment

Select the setting item "CH3 or CH4 UP" using the (JOG) button up or down operation, and set the 3rd or 4th channel dial fully to the up using (+ side) and use the (+) or (-) buttons to adjust the servo angle.

### 2 3rd/4th channel servo (down position) adjustment

Select the setting item "CH3 or CH4 DWN" using the (JOG) button up or down operation, and set the 3rd or 4th channel dial fully to the up position (- side) and use the (+) or (-) buttons to adjust the servo angle.

### 3 When completed, return to the MENU1 screen by pressing the (JOG) button.

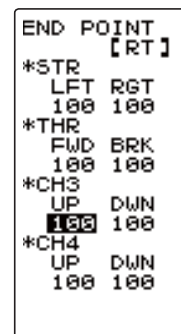

#### Adjust button

- Adjust with the (+) and (-) buttons.
- Return to the initial value "100" by pressing the (+) and (-) buttons simultaneously for about 1 second.

#### 3rd & 4th channel EPA

CH3/CH4 UP :0~120  
 CH3/CH4 DWN :0~120  
 Initial value :100

# Fail Safe Function "FAIL SAFE"

(All channel)

## Fail Safe Mode (F/S)

This function moves each servo to a preset position when the receiver does not receive a clear signal from the transmitter.

-When the condition set at "FHSS" is Rx type, fail safe (F/S) can be set only for throttle (TH). Other channels are set to the normal mode.

-The fail safe data is transferred from the transmitter to the receiver 10 seconds after the transmitter power is turned on. The data is transferred every 5 seconds after that. Be careful because normally the transmitter power is turned on first and the receiver power is turned on next and the data is transferred for approximately 10 seconds after the receiver power is turned on.

-For gasoline engine cars, for safety we recommend that this fail safe function be used to set the throttle channel in the direction in which the brakes are applied.

## Hold mode (HOLD)

This function holds the servo/s at the position they were in immediately before reception was lost. This applies to the T-FHSS type (R304SB...,etc.) and the S-FHSS type (R2104GF...,etc.) receivers only. When the receiver used is an R603GF/2004GF or other FHSS type, this function is not available.

## Off mode (OFF)

In this model the receiver stops outputting a signal to the servos if the transmitter signal is lost. The servos become effectively unpowered.

The F/S, HOLD, and OFF modes are automatically reset when signals from the transmitter can be received again.

## Battery fail safe function (BFS)

If the receiver battery voltage drops below a certain value when this function is enabled, the throttle servo moves to the position set by fail safe function. When the battery voltage recovers, the battery fail safe function is automatically reset.

-This function cannot be used when the throttle (TH) is not set to fail safe (F/S).

-This function is for the T-FHSS type (R304SB...,etc.) and the S-FHSS type (R2104GF...,etc.) receiver only. It cannot be used with the R603GF and R2004FG and other FHSS type.

Display to "FAIL SAFE" screen by the following method:

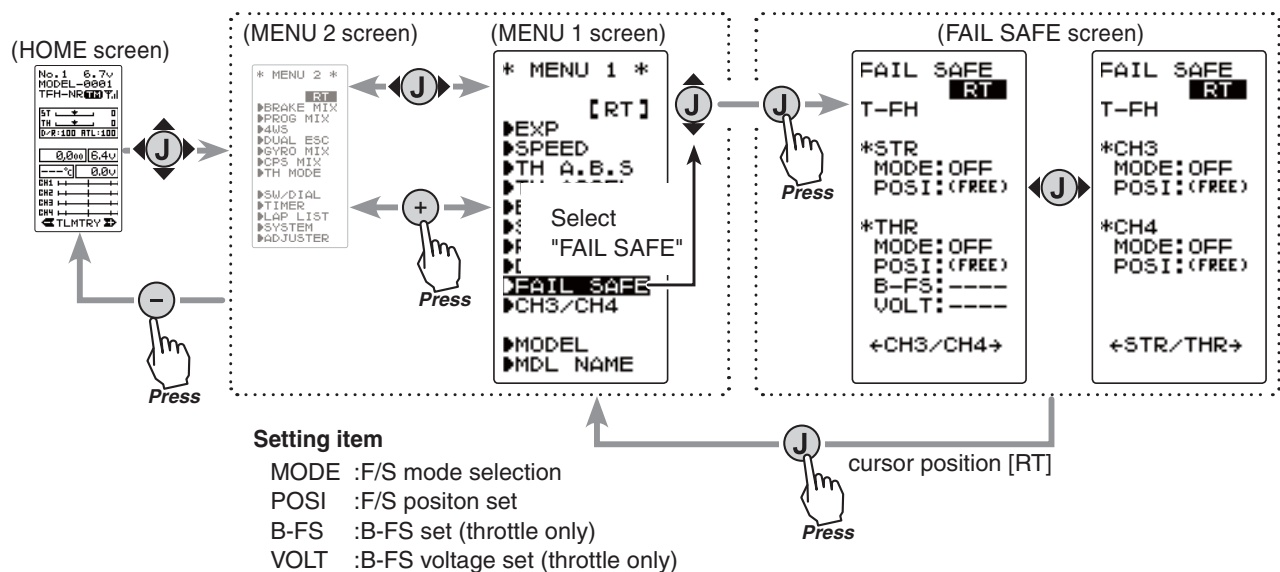

## Fail safe mode selection

(Preparation)

- Select the channels "MODE" to be set using the (JOG) button up, down, left, or right operation.

### 1 (Mode selection)

Select the mode by (+) or (-) button.

(Each channel can be individually set.)

### 2

When completed, move the cursor to [RT] using the (JOG) button, and return to the MENU1 screen by pressing the (JOG) button. When setting fail safe,

set the servo position by the following method.

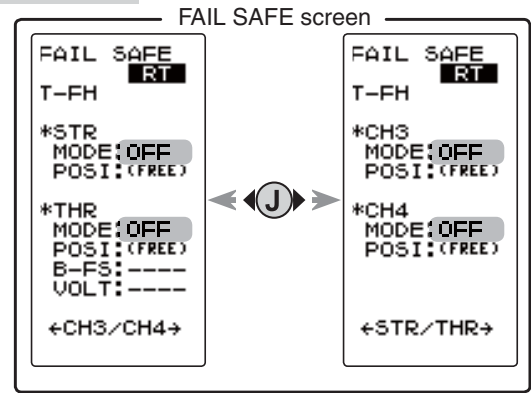

#### F/S mode

OFF, HOLD, F/S

#### F/S mode selection

- Select with the (+) or (-) buttons.

#### F/S position setup button

- The (JOG) buttons is pressed for about 1 second.

## Fail safe function setup

### 1 (Servo position setup)

When the fail safe function operates, select the setting item "POSI" using the (JOG) button. The steering stick, the throttle stick or 3rd, 4th channel dial should be positioned as required in the event that the failsafe activates. When the (JOG) button is pressed for about 1 second, the servo position is displayed and you can confirm that the function was set.

(Each channel can be set similarly.)

### 2

When completed, move the cursor to [RT] using the (JOG) button, and return to the MENU1 screen by pressing the (JOG) button.

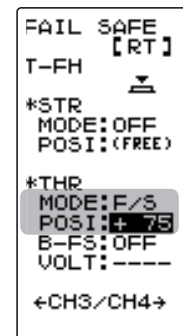

## Battery fail safe function ON/OFF (T-FHSS/ S-FHSS)

(Preparation)

- Select the setting item using the (JOG) button. For Battery F/S function ON/OFF, select "OFF" or "ACT" of "B-FS".

For voltage setting, select RX\*\*v. (The T-FHSS system only.)

The S-FHSS system is fixed at 3.8v.

### 1 (Battery fail safe function ACT/OFF)

BATT-F/S function ACT/OFF and voltage setting which activates the B-F/S function can be switched by (+) or (-) button.

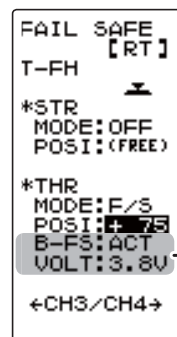

#### Battery fail safe function

OFF, ACT

Initial value: OFF

#### B-F/S Voltage

3.8, 4.0, 4.2, 4.4, 4.6, 4.8, 5.0, 5.3, 5.6, 5.9, 6.2, 6.5, 6.8, 7.1, 7.4(V)

Initial value 3.8v

Example:

NiMH /NiCd 4cell---3.8V

NiMH /NiCd 6cell---4.4V

LiFe 2cell---4.8V

LiPo 2cell---5.6V

### 2

When completed, move the cursor to [RT] using the (JOG) button, and return to the MENU1 screen by pressing the (JOG) button.



# Exponential Adjustment "EXP" (Steering/Throttle system)

This function is used to change the sensitivity of the servo around the neutral position. Display to "EXP" screen by the following method:

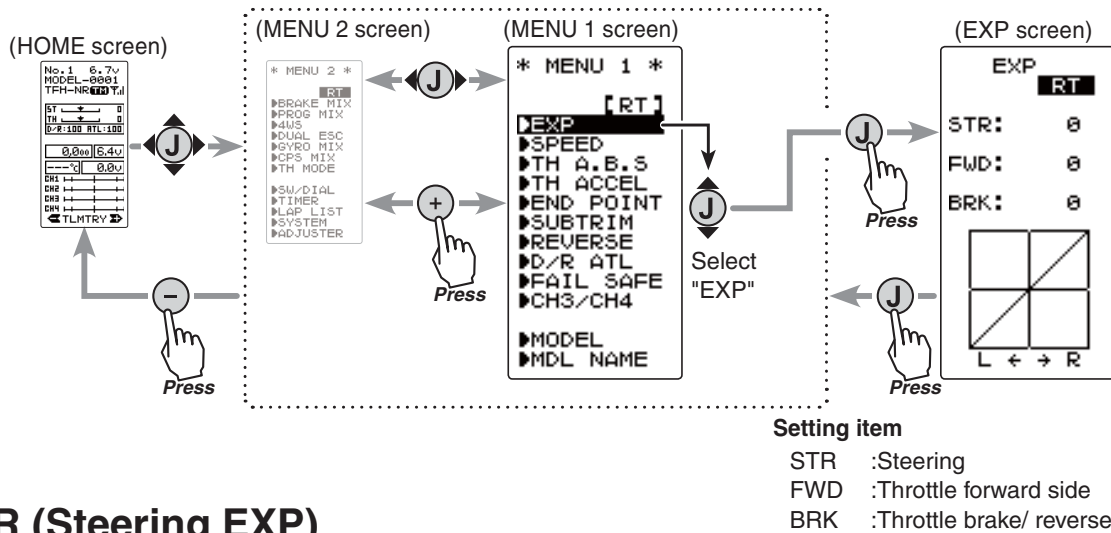

## STR (Steering EXP)

This function is used to change the sensitivity of the steering servo around the neutral position. It has no effect on the maximum servo travel.

### Racers Tip

When the setting is not determined, or the characteristics of the model are unknown, start with 0%. (When EXP is set to 0%, servo movement is linear.)

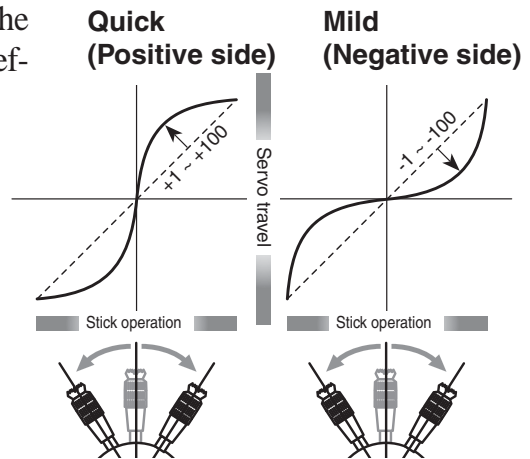

### Steering EXP adjustment

(Preparation)

- On the EXP screen, Select the setting item "STR" using the (JOG) button.

- 1 When you want to speed up initial steering operation, use the (+) button to adjust the + side. When you want to make steering operation gentler initially, use the (-) button to adjust the - side.

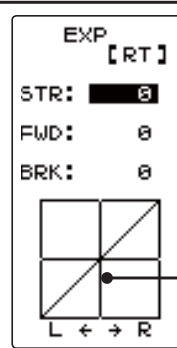

**Adjustment range**  
-100~0~+100

#### Adjust button

- Adjust with the (+) and (-) buttons.
- Return to the initial value "0" by pressing the (+) and (-) buttons simultaneously for about 1 second.

Vertical cursor moves in step with steering stick operation.

- 2 When completed, return to the MENU1 screen by pressing the (JOG) button.



Function

# FWD (Throttle Forward Side EXP) BRK (Throttle Brake Side EXP)

This function is used to change the sensitivity of the throttle/brake servo/ESC around the neutral position. It has no effect on the servo maximum operation amount.

## Advice

When the course conditions are good and the surface has good grip, set each curve to the + side (faster initial response). When the road surface is slippery and the tyres do not have good grip, set each curve to the - side (gentler initial response).

## Full throttle EXP adjustment

(Preparation)

- On the EXP screen make the following adjustments:

**1** Select the setting item "FWD" using the (JOG) button up or down operation.

Use the (+) button to adjust for a faster initial throttle response or use the (-) button for a gentler throttle response.

**Adjustment range**  
-100 ~ 0 ~ +100%

### Adjust button

Adjust with the (+) and (-) buttons.  
- Return to the initial value "0" by pressing the (+) and (-) buttons simultaneously for about 1 second.

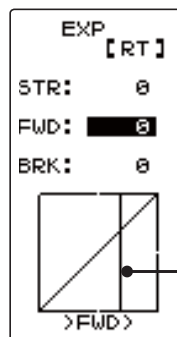
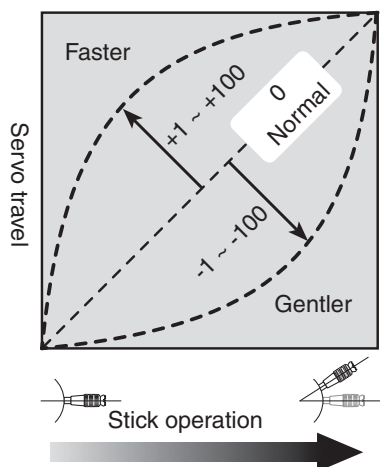

Vertical cursor moves in step with throttle stick operation.

**2** When completed, return to the MENU1 screen by pressing the (JOG) button.

## Throttle brake side EXP adjustment

(Preparation)

\*This function is not available in "TH-STK : F10 mode"

- On the EXP screen make the following adjustments:

**1** Select the setting item "BRK" using the (JOG) button up or down operation.

Use the (+) button to adjust for a faster initial throttle response or use the (-) button for a gentler throttle response.

### Adjustment range

-100 ~ 0 ~ +100%

### Adjust button

Adjust with the (+) and (-) buttons.

- Return to the initial value "0" by pressing the (+) and (-) buttons simultaneously for about 1 second.

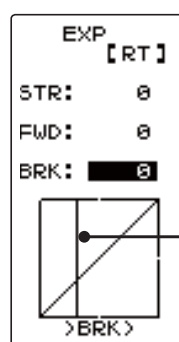
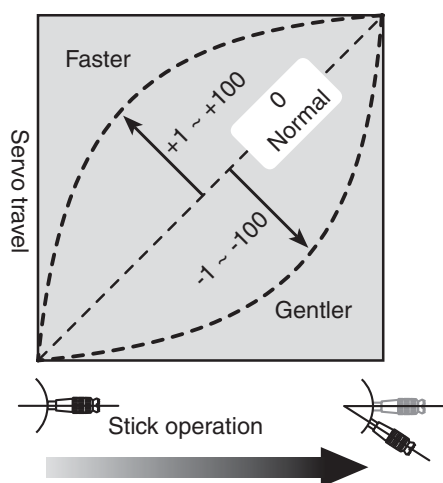

Vertical cursor moves in step with throttle stick operation.

**2** When completed, return to the MENU1 screen by pressing the (JOG) button.

## Dial / Trim Setting

The steering and throttle EXP adjustment (RATE) can be controlled with digital dial or digital trim with the function select switch dial function.

# Servo Speed "SPEED"

(Steering system)

This function is used to change the servo speed.

Display to "SPEED" screen by the following method:

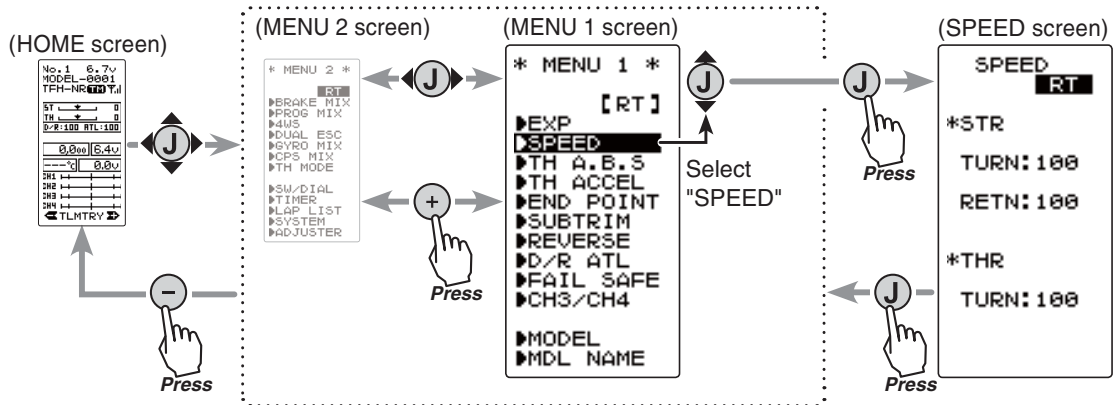

**Setting item**

- STR TURN :Steering application
- STR RETN :Steering return to neutral
- THR TURN :Throttle application

## STR (Steering Speed)

Over quick steering may cause momentary understeer, loss of speed or even a spin - the steering speed function can be effective in these cases.

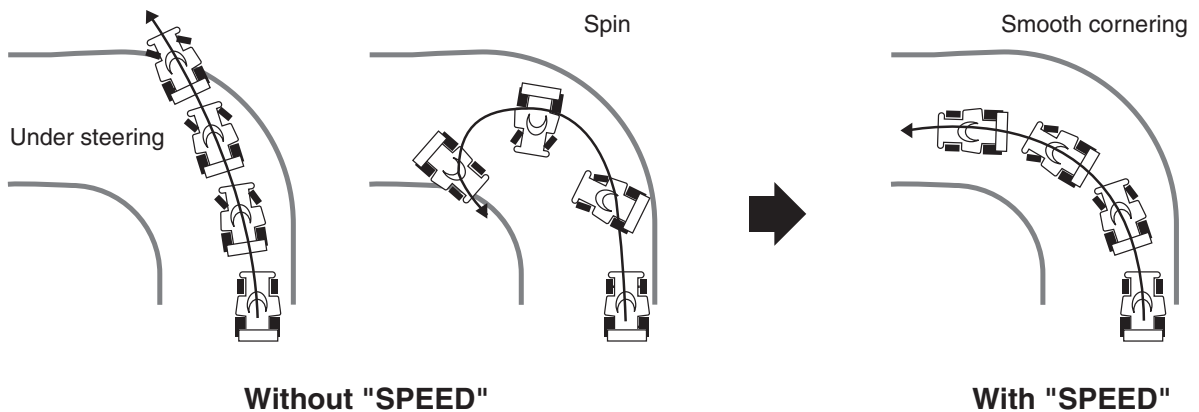

Function

### Operation

- This function limits the maximum speed of the steering servo. (Delay function)
- The steering speed when the steering stick is operated (TURN direction) and returned (RETN direction) can be independently set.
- If the steering stick is moved more slowly than the set speed, the steering servo is not affected.

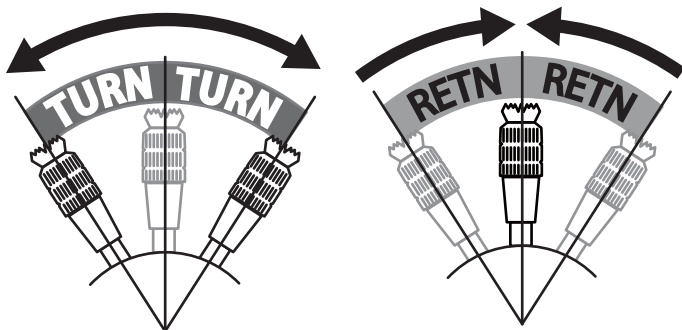

## Steering Speed adjustment

(Preparation)

- On the SPEED screen make the following adjustments:

### 1 "TURN" direction adjustment

On the SPEED screen, Select the setting item STR "TURN" using the (JOG) button up or down operation and use the (+) or (-) buttons to adjust the delay amount.

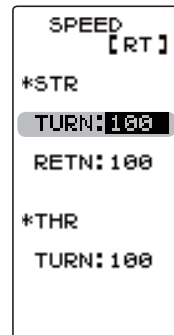
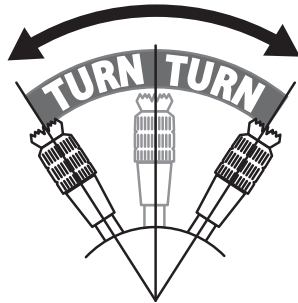

#### Adjustment range

1~100% (each direction)  
At 100%, there is no delay.

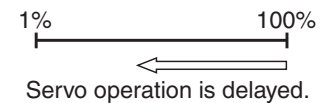

#### Adjust button

- Adjust with the (+) and (-) buttons.
- Return to the initial value "100" by pressing the (+) and (-) buttons simultaneously for about 1 second.

### 2 "RETN" direction adjustment

Select the setting item STR "RETN" using the (JOG) button up or down operation and use the (+) or (-) buttons to adjust the delay amount.

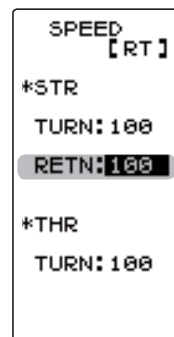
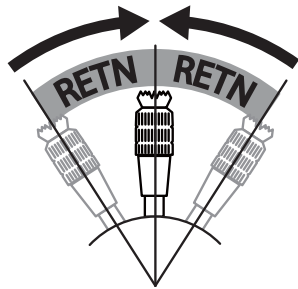

#### Adjustment range

1~100% (each direction)  
At 100%, there is no delay.

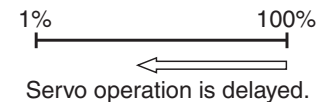

#### Adjust button

- Adjust with the (+) and (-) buttons.
- Return to the initial value "100" by pressing the (+) and (-) buttons simultaneously for about 1 second.

3 When completed, return to the MENU1 screen by pressing the (JOG) button.

### Setting example (Steering servo: BLS471SV / BLS371SV) ... (Setting criteria)

- Onroad TURN side: Approx. 50~80% RETURN side: Approx. 60~100%
- Offroad TURN side: Approx. 70~100% RETURN side: Approx. 80~100%

### Dial / Trim Setting

The steering speed adjustment "TURN" and "RETN" can be controlled with digital dial or digital trim with the function select switch dial function.

## THR (Throttle Speed)

Sudden throttle stick operation on a slippery surface will cause the wheels to spin, resulting in poor acceleration. Setting the throttle speed function reduces wasteful battery consumption while at the same time enabling smooth, enjoyable operation.



With "SPEED": Quick start without skidding



Without "SPEED": Slow start due to skidding

### Operation

-Throttle servo (ESC) operation is slowed when the throttle stick is pushed forward so that the wheels will not spin even if the throttle is opened faster than required.

This function is not active when the stick is pulled back for brake/reverse.

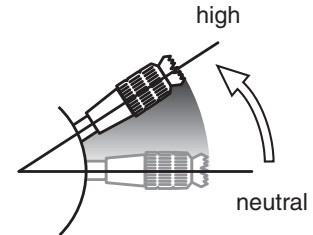

### Throttle Speed adjustment

(Preparation)

- On the SPEED screen make the following adjustments:

#### 1 (Delay adjustment)

On the SPEED screen, Select the setting item THR "TURN" using the (JOG) button up or down operation and use the (+) or (-) buttons to adjust the delay amount.

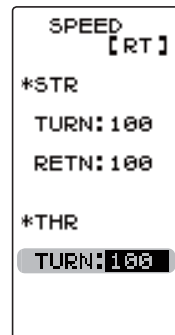

#### Adjustment range

1~100%

At 100%, there is no delay.

1% 100%

←  
Servo operation is delayed.

#### Adjust button

- Adjust with the (+) and (-) buttons.
- Return to the initial value "100" by pressing the (+) and (-) buttons simultaneously for about 1 second.

#### 2

When completed, return to the MENU1 screen by pressing the (JOG) button.

### Dial / Trim Setting

The throttle speed adjustment can be controlled with digital dial or digital trim with the function select switch dial function.

# Throttle Acceleration "TH ACCEL"

(Throttle system)

The throttle servo will "jump" to a preset position at its maximum possible speed. Unlike exponential, which adjusts the whole throttle movement into a curve, throttle acceleration simply "jumps" away from neutral and then leaves the remaining response linear.

## Operation

- Operation near the throttle trigger neutral position becomes an abrupt rise.
- The forward and brake sides can be set separately.
- When the brake mixing function is set, the CH3/CH4 brake can also be set.

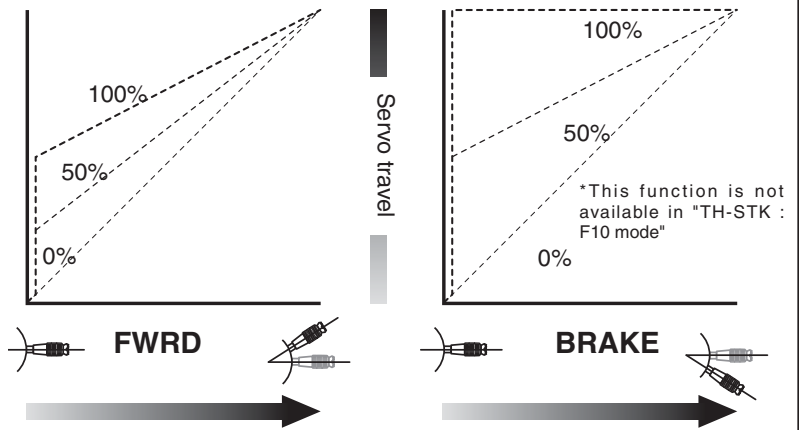

## Set value

The standard value (100% point) of this setup affects the operation amount set by throttle EPA function.

## Convenient usage method

For GP cars, the linkage must have a clearance because one servo controls the engine carburetor and brake. Thus, there is a noticeable time delay at both the forward and brake sides. Sharp response comparable to that of electric motor cars is obtained by reducing this clearance at the transmitter side.

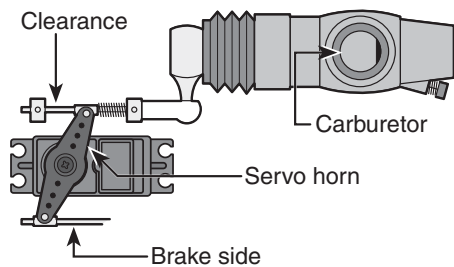

Display to "TH ACCEL" screen by the following method:

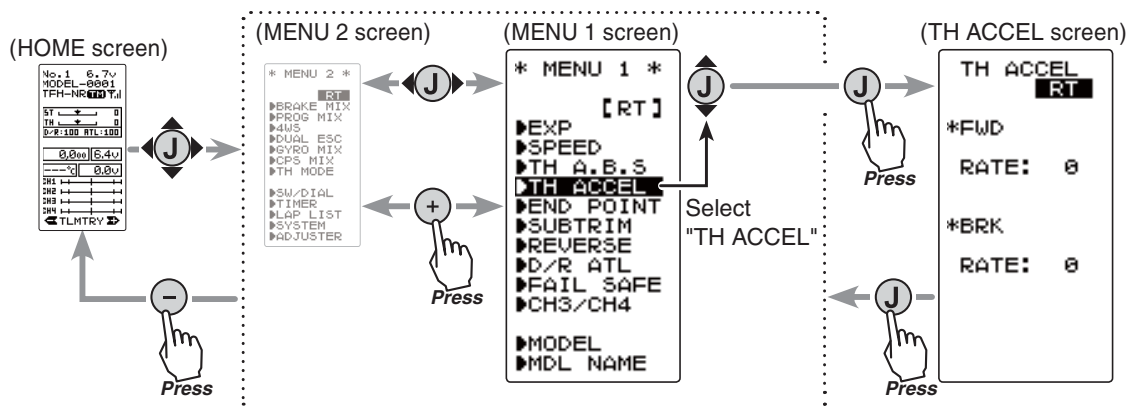

### Setup item

- FWR RATE :Forward side acceleration
- BRA RATE :Brake side acceleration

Function

## Throttle acceleration adjustment

(Preparation)

- On the TH ACCEL screen make the following adjustments:

### 1 (Forward acceleration amount adjustment)

Select the setting item FWD "RATE" using the (JOG) button up or down operation and use the (+) and (-) buttons to adjust the acceleration amount.

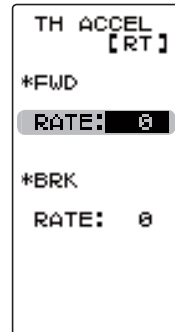

"0" :No acceleration

"100" :Maximum acceleration (Approximately 1/2 of the forward side throttle angle)

### Forward acceleration amount (FWD)

0~100

Initial value: 0

### Adjust button

Adjust with the (+) and (-) buttons.

- Return to the initial value "0" by pressing the (+) and (-) buttons simultaneously for about 1 second.

### 2 (Brake side acceleration amount adjustment)

Select the setting item BRK "RATE" using the (JOG) button up or down operation and use the (+) and (-) buttons to adjust the acceleration amount.

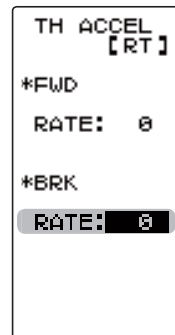

"0" :No acceleration

"100" :Maximum acceleration (Brake side maximum throttle angle)

### Brake side acceleration amount (BRK)

0~100

Initial value: 0

### Adjust button

Adjust with the (+) and (-) buttons.

- Return to the initial value "0" by pressing the (+) and (-) buttons simultaneously for about 1 second.

4 When completed, return to the MENU1 screen by pressing the (JOG) button.

## Dial / Trim Setting

The throttle acceleration adjustment amount (FWD), (BRK) can be controlled with digital dial or digital trim with the function select switch dial function.



# A.B.S. Function "TH A.B.S"

(Throttle system)

When the brakes are applied while cornering with a 4 Wheel Drive or other type of vehicle, understeer may occur. This understeer can be eliminated and cornering improved using this function.

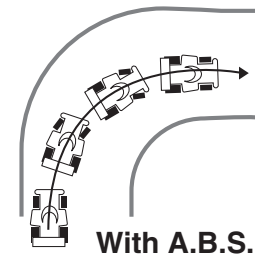
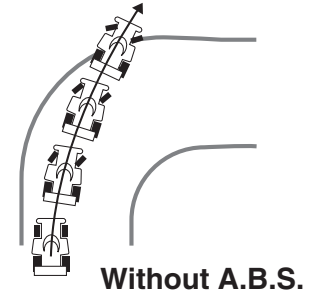

## Operation

- When the brakes are applied, the throttle servo will pulse intermittently. This will have the same effect as pumping the brakes in a full size car.
- The brake return amount, delay amount, pulse cycle, and brake duty can be adjusted.

## Operation display

During ABS operation, the LED blinks.

Display "TH A.B.S" screen by the following method:

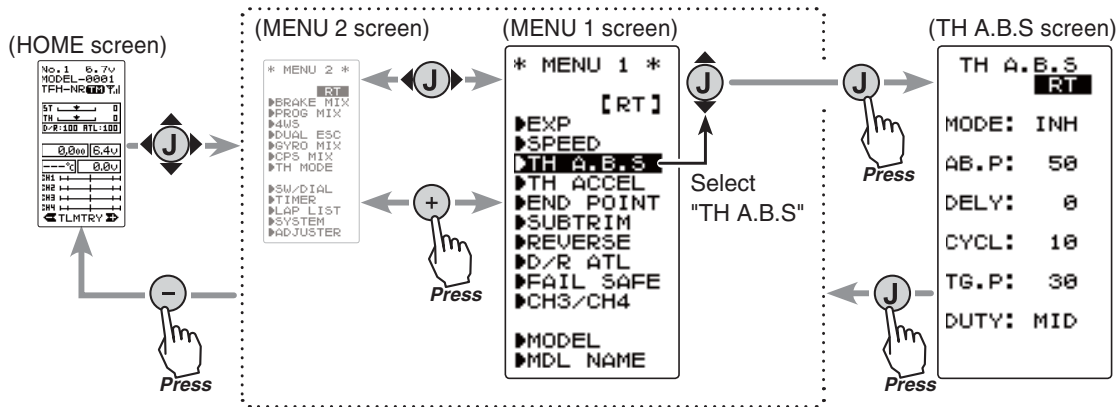

### Setup items

- |      |                       |      |                    |
|------|-----------------------|------|--------------------|
| MODE | : Function ON/Off     | CYCL | : Cycle speed      |
| AB.P | : Brake return amount | TG.P | : Starting point   |
| DELY | : Delay amount        | DUTY | : Cycle duty ratio |

### - AB.P : Amount of brake return

Sets the rate at which the servo returns versus stick operation for brake release. When set to 0%, the ABS function is not performed. When set to 50%, the servo returns 50% (1/2) of the stick operation amount and when set to 100%, the servo returns to the neutral position.

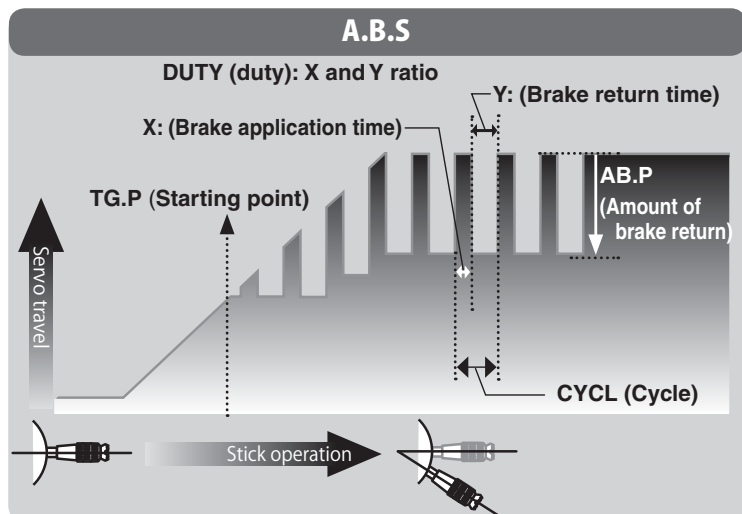

Function

**- DELY : Delay**

Sets the delay from brake operation to ABS operation. When set to 0%, the ABS function is activated without any delay. At 50%, the ABS function is activated after a delay of approximately 1 second and at 100%, the ABS function is activated after a delay of approximately 2 seconds.

**- CYCL : Cycle speed**

Sets the pulse speed (cycle). The smaller the set value, the faster the pulse cycle.

**- TG.P : Starting point**

Sets the starting point at which the ABS function begins to operate at brake operation.

**- DUTY : Cycle duty ratio**

Sets the proportion of the time the brakes are applied and the time the brakes are released by pulse operation. The ratio can be set to HIGH, MID or LOW.

**- MODE : Function ON/OFF**

ABS function ON/OFF setting. When using the ABS function, set to "ACT(ON)".

**A.B.S function adjustment**

**1** (Function ON/OFF)

Select the setting item "MODE" using the (JOG) button up or down operation. Set the function to the active state by pressing the (+) or (-) button.

- "INH(OFF)" :Function OFF
- "ACT(ON)" :Function ON
- "ACT(OFF)" :Switch OFF when setting switches

**Select button**

- Select with the (+) or (-) buttons.

**Function ON/OFF (MODE)**

INH(OFF), ACT(ON,OFF)

**2** (Brake return amount adjustment)

Select the setting item "AB.P" using the (JOG) button up or down operation. Use the (+) or (-) button to adjust the return amount.

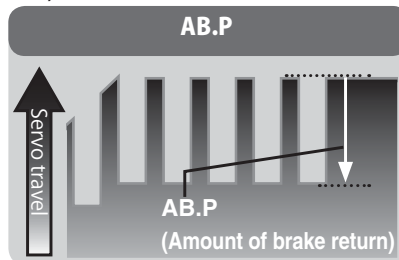

- "0" :No return
- "50" :Return to the 50% position of the brake operation amount
- "100" :Return to the neutral position.

**Brake return amount (AB.P)**

0 ~ 50 ~ 100  
Initial value: 50

- Brake return amount (AB.P) is influenced by the "EXP" rate on the brake side.

**Adjustment buttons**

- Use the (+) and (-) buttons to make adjustments.  
- Return to the initial value by pressing the (+) and (-) buttons simultaneously (approx. 1 sec).

**3** (Delay amount setup)

Select the setting item "DELY" using the (JOG) button up or down operation. Use the (+) or (-) button to adjust the delay amount.

- "0" :A.B.S. function performed without any delay
- "50" :A.B.S function performed after an approximate 1 sec delay.
- "100" :A.B.S. function performed after an approximate 2 secs delay.

**Delay amount (DELY)**

0 ~ 100  
Initial value: 0

**Adjustment buttons**

- Use the (+) and (-) buttons to make adjustments.  
- Return to the initial value by pressing the (+) and (-) buttons simultaneously (approx. 1 sec).

- 4** (Cycle speed adjustment)  
Select setting item "CYCL" using the (JOG) button up or down operation. Use the (+) or (-) button to adjust the pulse speed (cycle).

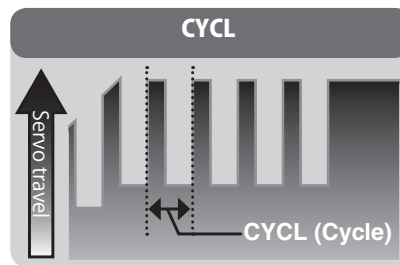

**Cycle speed (CYCL)**

1 ~ 30  
Initial value: 10

**Adjustment buttons**

- Use the (+) and (-) buttons to make adjustments.
- Return to the initial value by pressing the (+) and (-) buttons simultaneously (approx. 1 sec).

- The smaller the set value, the faster the pulse speed.

- 5** (Starting point setup)  
Select setting item "TG.P" using the (JOG) button up or down operation. Use the (+) or (-) button to adjust the operation point.

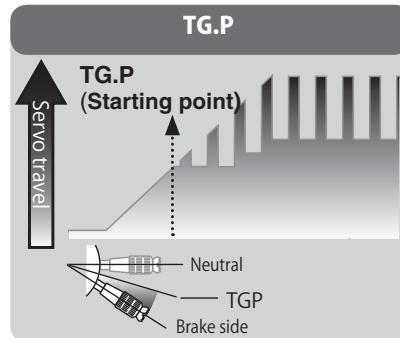

**Starting point (TG.P)**

10 ~ 100  
Initial value: 30

**Adjustment buttons**

- Use the (+) and (-) buttons to make adjustments.
- Return to the initial value by pressing the (+) and (-) buttons simultaneously (approx. 1 sec).

- Sets the throttle stick position at which the A.B.S. function is performed. The number is the % display with the full brake position being 100.

- 6** (Cycle duty ratio setup)  
Select setting item "DUTY" using the (JOG) button up or down operation. Use the (+) or (-) button to adjust the duty ratio.

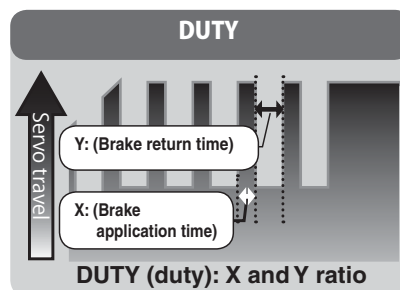

**Duty ratio (DUTY)**

LOW - MID - HIGH  
Initial value: MID

**Adjustment buttons**

- Use the (+) and (-) buttons to make adjustments.
- Return to the initial value by pressing the (+) and (-) buttons simultaneously (approx. 1 sec).

"LOW" :Brake application time reduced to minimum.(Brakes lock with difficulty)

"HIGH" :Brake application time increased to maximum. (Brakes lock easily)

(Remark) For low grip, set at the LOW side and for high grip, set at the HIGH side.

- 7** When completed, return to the MENU1 screen by pressing the (JOG) button.

**Dial / Trim Setting**

The brake return amount (AB.P), delay amount (DELY) and cycle (CYCL) can be controlled with digital dial or digital trim with the function switch dial function.

**Switch setting**

Use SW1 or SW2 to switch the A.B.S. function ON/OFF.

See the function select switch dial function.

## Fail Safe Unit

When the T4GRS is used with the Futaba fail safe unit (FSU), it will operate as described below. However, FSU-1 cannot be used in the high speed mode.

- When the FSU is connected to the throttle channel, and the A.B.S. function has been activated, the FSU LED will flash each time the servo operates. The reason for this is that the FSU responds to sudden data changes caused by A.B.S. function pumping operation. It does not mean that the fail safe function is activated. The servo will not be affected.

## Example of A.B.S. function setting when BLS371SV used (There will be a slight difference decompleted on the state of the linkage.)

- Basic setting

AB.P: Approx. 30% (If this value is too high, the braking distance will increase.)

CYCL: 5~7

DUTY: (When grip is low: LOW side, when grip is high: HIGH side)

DELY: 10~15%

TG.P: Approx. 70%

- When the wheels lock or the car spins, when the brakes are applied fully

AB.P: Increase from 30%

DUTY: Shift to "LOW" side

DELY: Reduce the delay

- When the braking is poor and thus the braking distance extended when the brakes are applied fully

AB.P: Decrease from 30%

DUTY: Shift to "HIGH" side

DELY: Increase the delay

## 1/5 scale car and others with independent brakes and ABS

ABS can be independently set for the brakes which are controlled by the 3rd CH and 4th CH by using the brake mixing (BRAKE MIX) function described. For more information, read the brake mixing (BRAKE MIX) item.

The channel 3/4 servo position can be set from the transmitter. When CH3 is assigned to a dial by the switch dial function, this setting is linked to that dial.

When CH3/4 is not assigned to a dial, it can be set with this screen.

When CH3/4 is assigned to a switch by the switch dial function, you cannot adjust the CH3/4 via the screen.

Display "CH3/CH4" screen by the following method:

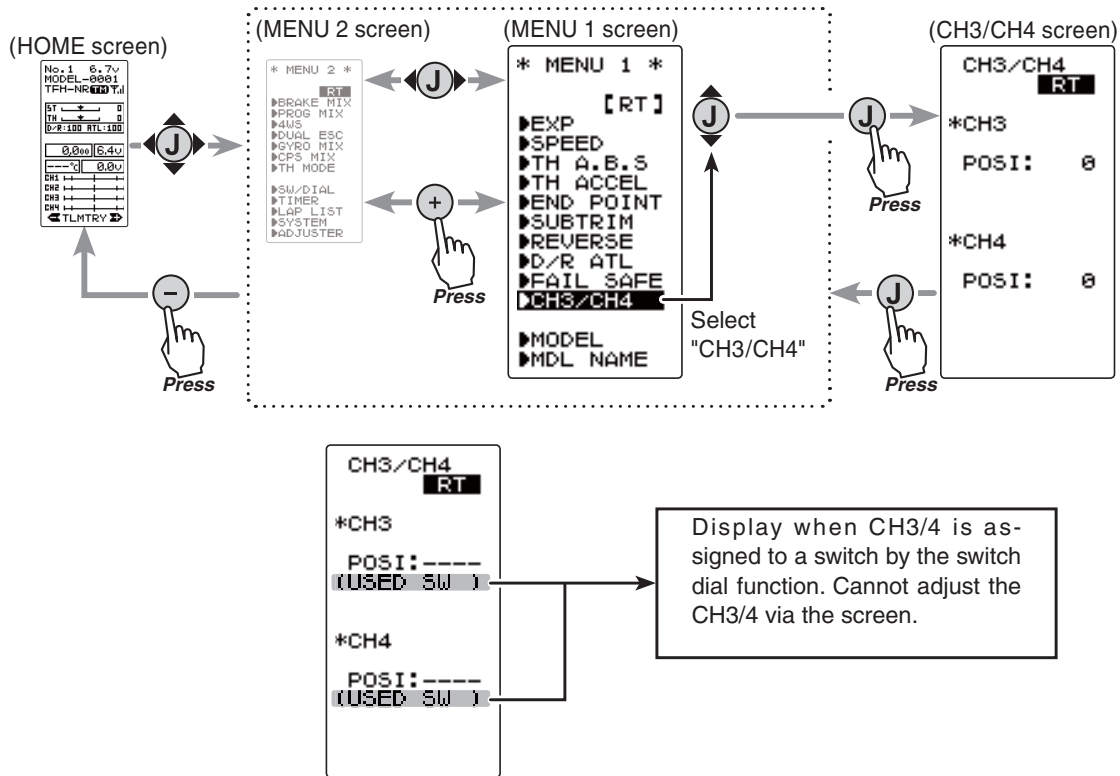

## Rate / position adjustment on channel menu screen

- 1** (Function selection)  
On each CH3/CH4 screen select CH3 "POSI" or CH4 "POSI" using the (JOG) button up or down operation.

---

- 2** (Position setting/rate adjustment)  
Use the (+) and (-) buttons to adjust the channel 3 or channel 4 position.

---

- 3** When completed, return to the MENU1 screen by pressing the (JOG) button.

**Channel 3 position (POSI)**  
**Channel 4 position (POSI)**  
0~100%  
Initial value: 0

**Adjust button**  
- Adjust with the (+) and (-) buttons.  
- Return to the initial value "100" by pressing the (+) and (-) buttons simultaneously for about 1 second.

# Steering Dual Rate/ Throttle ATL "D/R ATL"

## D/R (Steering dual rate)

The steering left and right servo travels are adjusted simultaneously. This setting is linked to transmitter DT3. When DT3 is assigned another function, dual rate can be adjusted with this screen.

## ATL (Throttle ATL)

This function decreases the set value when the braking effect is strong and increases the set value when the braking effect is weak. This function is linked to transmitter DT4. When DT4 is assigned another function, this function can be set with this screen.

Display "D/R ATL" screen by the following method:

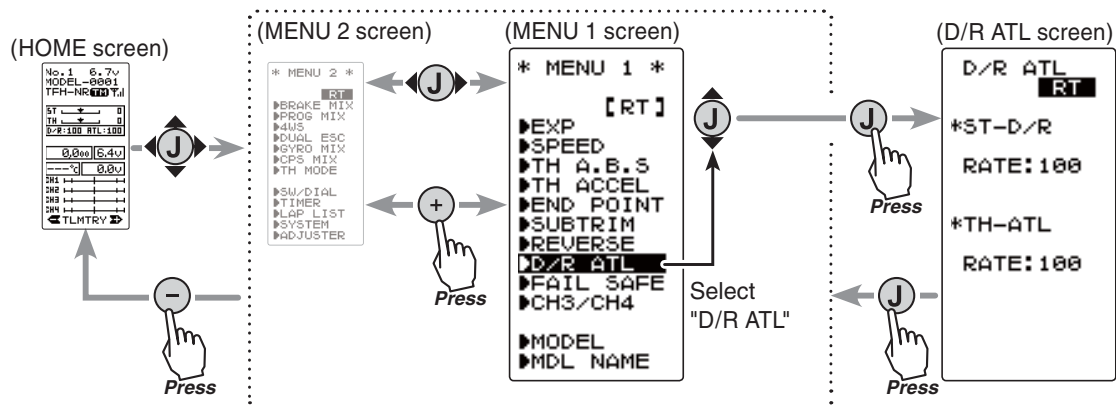

## Dual rate adjustment

### 1 (Dual rate adjustment)

Select the setting item ST-D/R "RATE" using (JOG) button up or down operation. Adjust the servo travel with the (+) and (-) buttons.

### 2 When completed, return to the MENU1 screen by pressing the (JOG) button.

### D/R rate (RATE)

0~100%  
Initial value: 100

### Adjust button

- Adjust with the (+) and (-) buttons.
- Return to the initial value "100" by pressing the (+) and (-) buttons simultaneously for about 1 second.

## ATL function adjustment \*This function is not available in "TH-STK : F10 mode".

### 1 (Brake amount adjustment)

Select the setting item TH-ATL "RATE" using (JOG) button up or down operation. Adjust the servo travel with the (+) and (-) buttons.

### 2 When completed, return to the MENU1 screen by pressing the (JOG) button.

### ATL rate (RATE)

0~100%  
Initial value: 100

### Adjust button

- Adjust with the (+) and (-) buttons.
- Return to the initial value "100" by pressing the (+) and (-) buttons simultaneously for about 1 second.

# Select Switch Dial Function "SW/ DIAL"

Selection of the function to be performed by digital trim (DT1, DT2, DT3, DT4) dial (DL1) and switch (SW1, SW2).

- The functions that can be assigned to dial, digital trim and switch are listed on the next page.
- The dial and digital trim step amount can be adjusted. (The relationship between set value and step amount is shown in the table on the next page.)
- The direction of operation of the servos can be reversed. (NOR/REV)
- SW1 alternate operation (operation which switches between ON and OFF each time the switch is pressed) is possible.

NOR (Normal) -ON only while pressed, OFF when released.

ALT (Alternate) -Switched between ON and OFF each time pressed.

Display "SW/DIAL" screen by the following method:

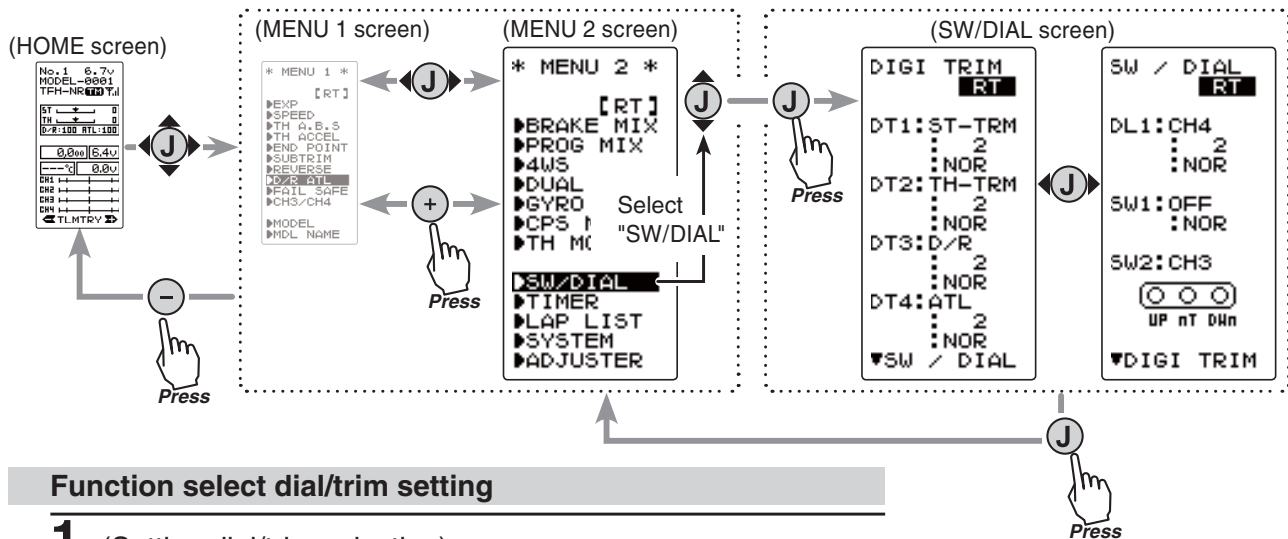

## Function select dial/trim setting

### 1 (Setting dial/trim selection)

Select the dial or trim you want to set using the (JOG) button up or down operation.

### 2 (Function setting)

Select the function with the (+) or (-) button.

- Refer to the list on the next page for the abbreviations of the functions.

(Step amount setting)

Select the step amount you want to set using the (JOG) button up or down operation. Use the (+) or (-) button to set the step amount.

- Refer to the next page for the relationship between set value and step amount.

(Changing the direction of operation)

Select the Direction of operation you want to set using the (JOG) button up or down operation. Use the (+) or (-) button to trim/dial the direction.

### 3 When completed, return to the MENU1 screen by pressing the (JOG) button.

\*Function selection  
\*Step amount setting  
\*Direction of operation setting

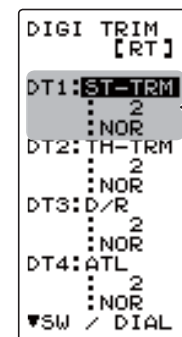

#### Adjust button

Adjust with the (+) and (-) buttons.

- Return to the initial value "2" by pressing the (+) and (-) buttons simultaneously for about 1 second.

Function

## Function select switch setting

### 1 (Setting SW selection)

Select the SW you want to set using the (JOG) button up or down operation.

### 2 (Function setting)

Select the function with the (+) or (-) button.

-Refer to the list for the abbreviations of the functions.

(Changing the SW1 operation system)

Select DIR of <SW1> using the (JOG) button up or down operation. Select ALT or NOR with the (+) or (-) button.

### 3 When completed, return to the MENU2 screen by pressing the (JOG) button.

Set table functions (DL1, DT1/DT2/DT3)	
Abbreviation used on setup screen	Function name, etc.
D/R	Dual rate function
ATL	ATL function
EXP-ST	Steering EXP
EXP-FW	Throttle EXP (Forward side)
EXP-BK	Throttle EXP (Brake side)
SPD-TN	Steering speed (Turn side)
SPD-RN	Steering speed (Return side)
ABS.PS	A.B.S. function (Return amount)
ABS.DL	A.B.S. function (Delay)
CYCLE	A.B.S. function (cycle speed)
ACC-FW	Throttle acceleration (Forward side)
ACC-BK	Throttle acceleration (Brake side)
TH-SPD	Throttle speed
ST-TRM	Steering trim
TH-TRM	Throttle trim
CH3	Channel 3
CH4	Channel 4
SUBTR1	Sub trim (CH1)
SUBTR2	Sub trim (CH2)
SUBTR3	Sub trim (CH3)
SUBTR4	Sub trim (CH4)
IDLE	Idle up function
ESC-RT	Dual ESC mixing (4ch ESC rate)
TH-OFF	Throttle off (engine cut)
PMX-A	Program mixing (RGHT/BRAK/DOWN sides)
PMX-B	Program mixing (LEFT/FWRD/UP sides)
BK3-RT	Brake mixing (3ch brake rate)
BK4-RT	Brake mixing (4th brake rate)
4WS-RT	4WS mixing (3ch steering rate)
ESC-MD	Dual ESC mixing (Drive mode select)
GYRO	Gyro mixing (Gain rate)
OFF	Not used

## Adjust button

Adjust with the (+) and (-) buttons.

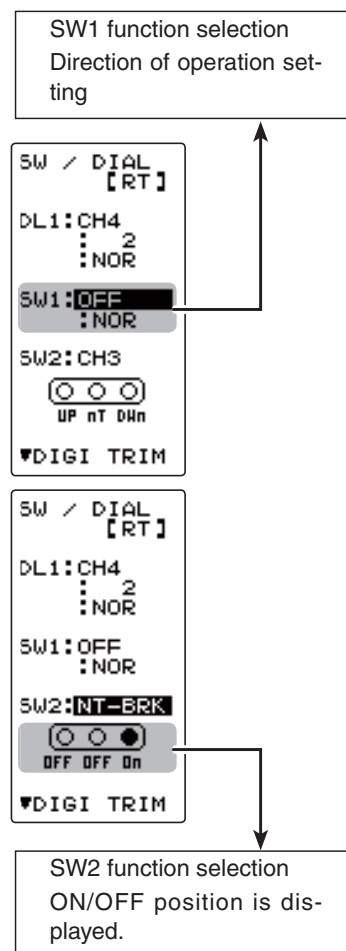

## Relationship between set value and step amount

(Setting range: 1~10, 20, 30, 40, 50, 100, 2P)

-Steering trim/throttle trim

When set to the minimum "1", the total trim operating width is 200 clicks. For "100", the total operating width is 2 clicks and for 2P, the total operating width is 1 click.

-Rate, etc. setting

This is the % value which is operated by 1 click relative to the set value of each rate. Since the total operating width of functions having a rate of -100~0~+100 is 200%, when set to "100", the total operating width is 2 clicks. Since the total operating width of functions with a 0~100 rate is 100%, "100" and 2P are operated by 1 click.

-Channel 3/4

When set to the minimum "1", the total operating width of channel 3 is 200 clicks. For "100", the total operating width is 2 clicks and 2P is operated by 1 click.



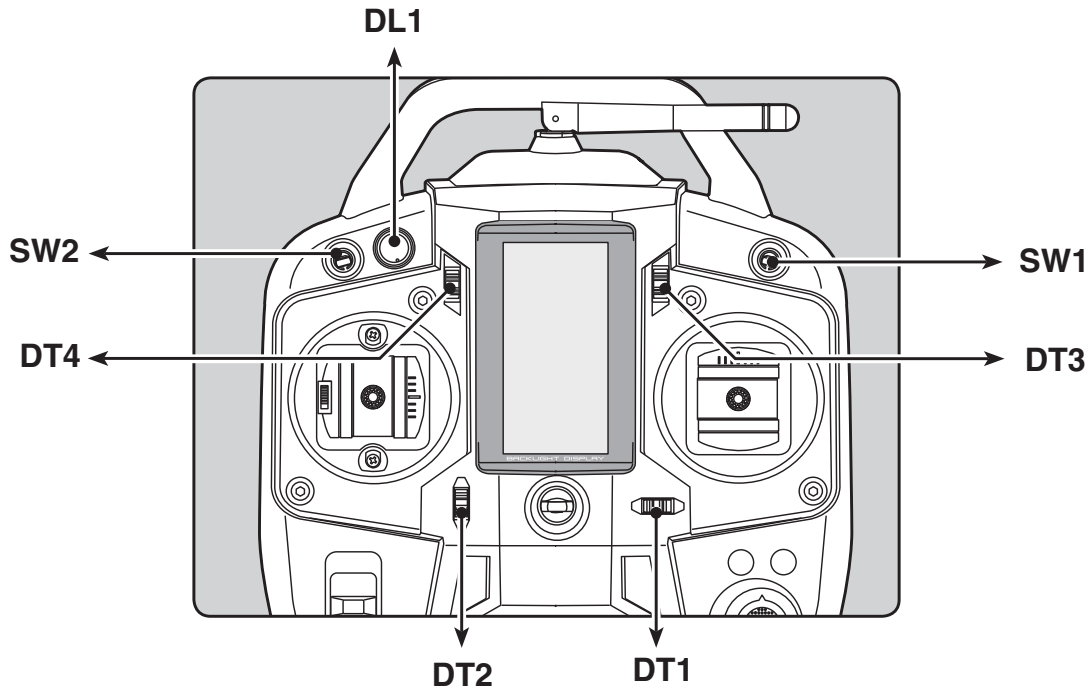

Set table functions (SW1)	
Abbreviation used on setup screen	Function name, etc.
NT-BRK	Neutral brake function ON/OFF
ABS	A.B.S function ON/OFF
IDLE	Idle up function ON/OFF
PRGMIX	Program mixing function ON/OFF
TH-OFF	Throttle off (engine cut) function ON/OFF
CH3	Channel 3
CH4	Channel 4
4WS MIX	4WS mixing type select
TIMER	Timer function start/stop
LOGGER	Telemetry log start/stop
GYRO	Switching GYRO mode
OFF	Not used

Set table functions (SW2)	
Abbreviation used on setup screen	Function name, etc.
NT-BRK	Neutral brake function ON/OFF
ABS	A.B.S function ON/OFF
IDLE	Idle up function ON/OFF
PRGMIX	Program mixing function ON/OFF
TH-OFF	Throttle off (engine cut) function ON/OFF
CH3	Channel 3
CH4	Channel 4
OFF	Not used



Function

## Brake Mixing "BRAKE MIX" (Throttle, 3rd /4th channel system)

This function is used when the front and rear brakes must be adjusted independently such as with a 1/5 scale GP car. This mixing uses the 2nd CH for the rear brakes and the 3rd or 4th CH for the front brakes, or controls the front brakes with the 3rd CH and 4th CH servos, or controls the 2nd CH by independent throttle and controls the rear and front brakes with the 3rd CH and 4th CH.

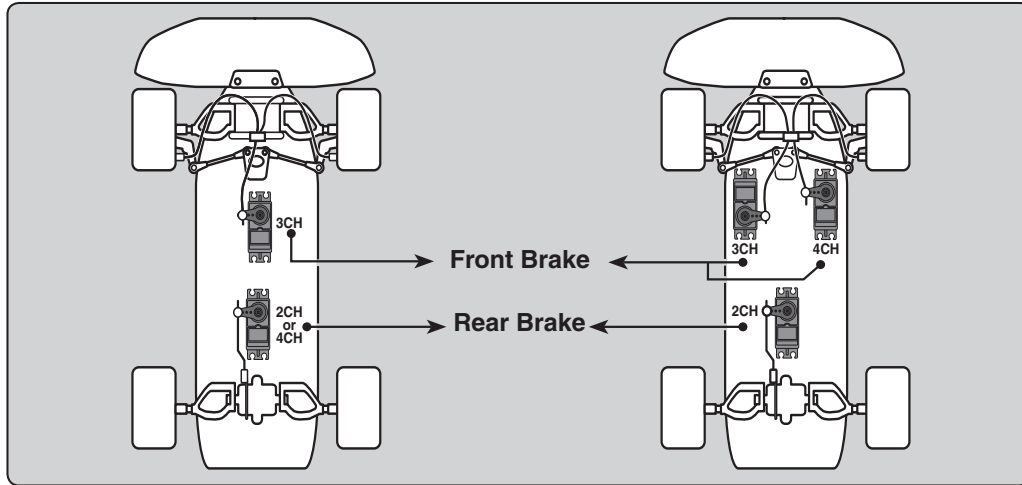

### Operation

- When braking, mixing is applied to 2nd CH→3rd CH, 4th CH.
- 3rd CH and 4th CH brake amount, 2nd CH, 3rd CH, and 4th CH brake delay, and 3rd CH and 4th CH brake ABS can be set.

### CH3/4 brake ABS function

The ABS function can be used independently at the CH3 and CH4 sides even when the CH2 side ABS function is OFF. The amount of pulsing speed (CYCL), operation point (TG.P), and duty ratio (DUTY) can be set in common with the CH2 side ABS function. (CH3 and CH4 brake return (AB.P) is fixed at 50.)

Display "SW/DIAL" screen by the following method:

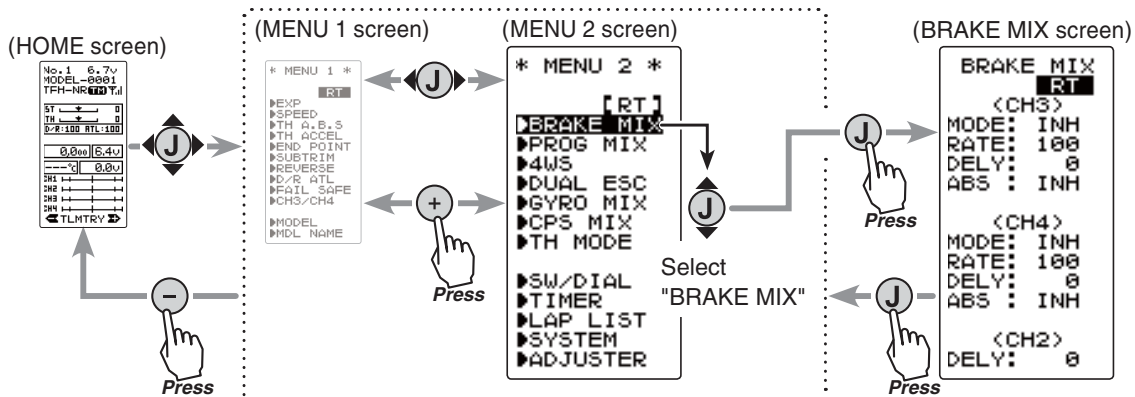

#### Setup item

<CH3>	<CH4>	<CH2>
MODE : Brake function ON/OFF	MODE : Brake function ON/OFF	DELY : Delay amount
RATE : Brake rate	RATE : Brake rate	
DELY : Delay amount	DELY : Delay amount	
ABS : ABS. function ON/OFF	ABS : ABS. function ON/OFF	

## Brake mixing adjustment

### 1 (Brake mixing function ON/OFF)

Using the (JOG) button, select "MODE" of <CH3> for CH3 brake and "MODE" of <CH4> for CH 4 brake.

Use the (+) or (-) button and set the function to the "ACT" state.

"INH" : Function OFF

"ACT" : Function ON

- When "(4WS>OFF)" is displayed below <CH3> ABS, the CH3 brake cannot be used if the 4WS function is not set to "ACT".

- When "(ESC>INH)" is displayed under <CH4> ABS, the CH4 brake cannot be used if the dual ESC function is not set to "INH".

#### Function ON/OFF (MODE)

INH, ACT

#### Select button

- Select with the (+) or (-) buttons.

### 2 (Brake rate)

Using the (JOG) button, select "RATE" of <CH3> for CH3 brake and "RATE" of <CH4> for CH 4 brake, and use the (+) and (-) buttons to adjust the Brake rate amount.

#### Brake rate (RATE)

0 ~ 100

Initial value:100

#### Adjustment buttons

- Use the (+) and (-) buttons to make adjustments.  
- Return to the initial value by pressing the (+) and (-) buttons simultaneously for about 1 second.

### 3 (Delay amount setup)

Using the (JOG) button, select "DELY" of <CH3> for CH3 brake, "DELY" of <CH4> for CH 4 brake and "DELY" of <CH2> for CH 2 brake. Use the (+) and (-) buttons to adjust the delay amount.

"0" : No delay

"100" : Maximum delay amount

#### Delay amount (DELY)

(CH3) 0 ~ 100

(CH4) 0 ~ 100

(CH2) 0 ~ 100

Initial value:0

### 4 (3rd & 4th channels brake-A.B.S ON/OFF)

Using the (JOG) button, select "ABS" of <CH3> for CH3 brake and "ABS" of <CH4> for CH 4 brake. Use the (+) or (-) button and set the function to the "ACT" state.

#### Function ON/OFF (ABS)

INH, ACT

#### Select button

- Select with the (+) or (-) buttons.

5 When completed, return to the MENU2 screen by pressing the (JOG) button.

#### Setting the 4WS mixing / dual ESC function

To use CH3 of the brake mixing function, 4WS mixing must be set to "INH".

To use CH4 of the dual ESC function and CPS mixing must be set to "INH".

#### Dial / Trim Setting

The function select switch dial function can control the 3rd/4th channels. Brake rate (RATE) can be controlled with digital dial or digital trim, using the function select dial function.

# Programmable Mix "PROG MIX"

(All channels)

This function allows you to apply mixing between the steering, throttle, channel 3 and channel 4.

## Additional Functions

- When the steering or throttle channel is the master channel (channel that applies mixing), trim data can be added. (Trim mode)
- The mixing mode selection. (Master mixing mode)

Relating function

- steering :EPA, STR EXP, D/R, SPEED, 4WS
- throttle :EPA, THR EXP, ATL, ABS, SPEED, BRAKE MIX, NT-BRK, ESC MIX, TH ACCEL
- CH3 :EPA,BRAKE MIX,4WS
- CH4 :EPA,BRAKE MIX,ESC MIX

## Movement of the slave channel side

The movement of the slave channel will be in proportion to the movement of the master channel.

Display "PROG MIX" screen by the following method:

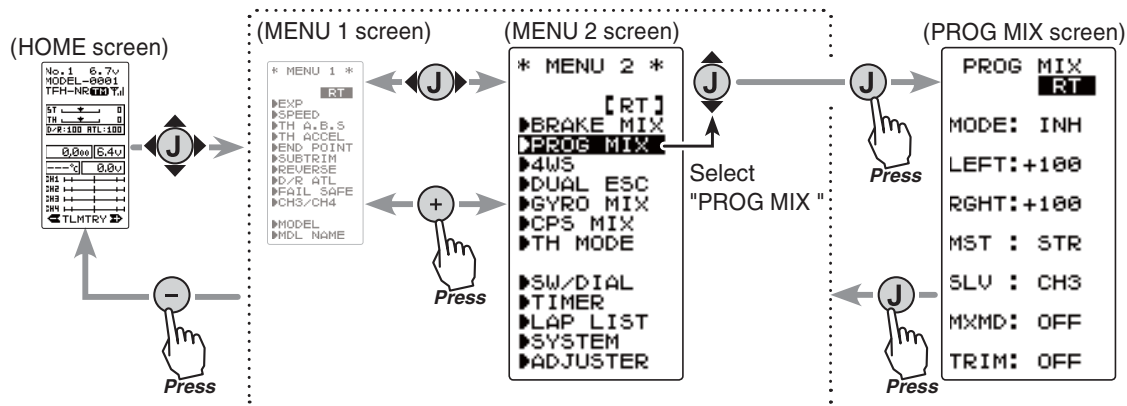

### Setup items

- MODE : Function ON/OFF
- LEFT : Mixing rate (Left side)
- RGHT : Mixing rate (Right side)
- MST : Master channel
- SLV : Slave channel
- MXMD : Mix mode
- TRIM : Trim mode

## Program mixing adjustment

(Preparation)

- When "PROG MIX" is turned ON and OFF by switch, set the switch by select switch dial function.

Function SW  
PROGMIX

### 1 (Mixing function ON/OFF)

Select the setting item "MODE" using the (JOG) button up or down operation. Use the (+) or (-) and set the function to the "ON" or "OFF" state.

- "INH" : Function OFF
- "ON" : Function ON. When the switch is OFF, "OFF" is displayed.

Function ON/OFF (MODE)

INH,ON(OFF)

Select button

- Select with the (+) or (-) buttons.

## 2 (Master channel)

Select setup item "MST" using the (JOG) button up or down operation, and select the master channel by pressing the (+) or (-) button.

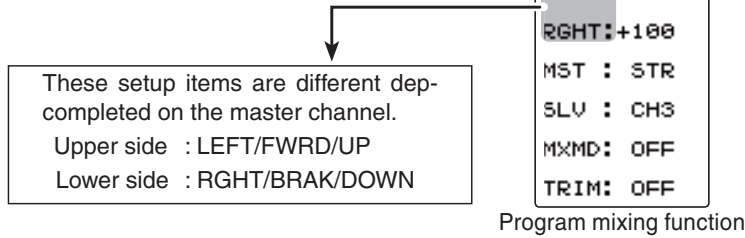

### Channel selection (MST)

STR, THR, CH3, CH4  
Initial value :STR

### Select button

- Select with the (+) or (-) buttons.

## 3 (Slave channel)

Select setup item "SLV" using the (JOG) button up or down operation, and select the slave channel by pressing the (+) or (-) button.

### Channel selection (SLV)

STR, THR, CH3, CH4  
Initial value :CH3

### Select button

- Select with the (+) or (-) buttons.

## 4 (Left, forward or up side mixing amount adjustment)

Select the setting item "LEFT", "FWRD", or "UP" using the (JOG) button up or down operation. Use the (+) or (-) button and adjust the left, forward, or up side mixing amount.

### Mixing amount

-120~0~+120  
Initial value: +100

### Adjust button

- Use the (+) and (-) buttons to make adjustments.  
- Return to the initial value "100" by pressing the (+) and (-) buttons simultaneously for about 1 second.

## 5 (Right, brake or down side mixing amount adjustment)

Select the setting item "RGHT", "BRAK", or "DOWN" using the (JOG) button up or down operation. Use the (+) or (-) button and adjust the right, brake, or down side mixing amount.

\*This function is not available in "TH-STK : F10 mode".

### Mixing amount

-120~0~+120  
Initial value: +100

## 6 (Mixing mode setup)

Select setup item "MXMD" using the (JOG) button up or down operation, and use the (+) or (-) button to select the mixing mode.

"OFF":Mixing proportional to master channel operation.

"MIX" :Mixing by master channel another function considered.

### Mixing mode (MXD)

OFF, ON  
Initial value: OFF

### Select button

- Select with the (+) or (-) buttons.

## 7 (Trim mode setup)

Select setup item "TRIM" using the (JOG) button up or down operation, and use the (+) or (-) button to select the mixing mode.

"OFF":Trim is removed.

"ON" :Trim is added.

### Trim mode (TRIM)

OFF, ON  
Initial value: OFF

### Select button

- Select with the (+) or (-) buttons.

8 When completed, return to the MENU2 screen by pressing the (JOG) button.

### Switch / Dial / Trim Setting

Select the program mixing function ON/OFF switch with the function select switch dial function. Mixing rate (RATE) can be controlled with digital dial or digital trim, using the function select switch dial function.

# 4WS Mixes "4WS"

(Steering, 3rd channel system)

This function can be used with crawlers and other 4WS type vehicles. It is mixing which uses the 1st CH to control the front axle steering and the 3rd CH to control the rear axle steering.

OFF (front axle only), reverse steer, same steer, rear axle only and other 4WS type switching is used by selecting SW1 with the function select switch function. If not selected, <NO SW> is displayed. Therefore, select SW1.

## Setting Special mixings

When the 3rd CH was set to ACT at Brake Mixing or when Gyro Mixing is used, 4WS mixing cannot be used.

Display "4WS" screen by the following method:

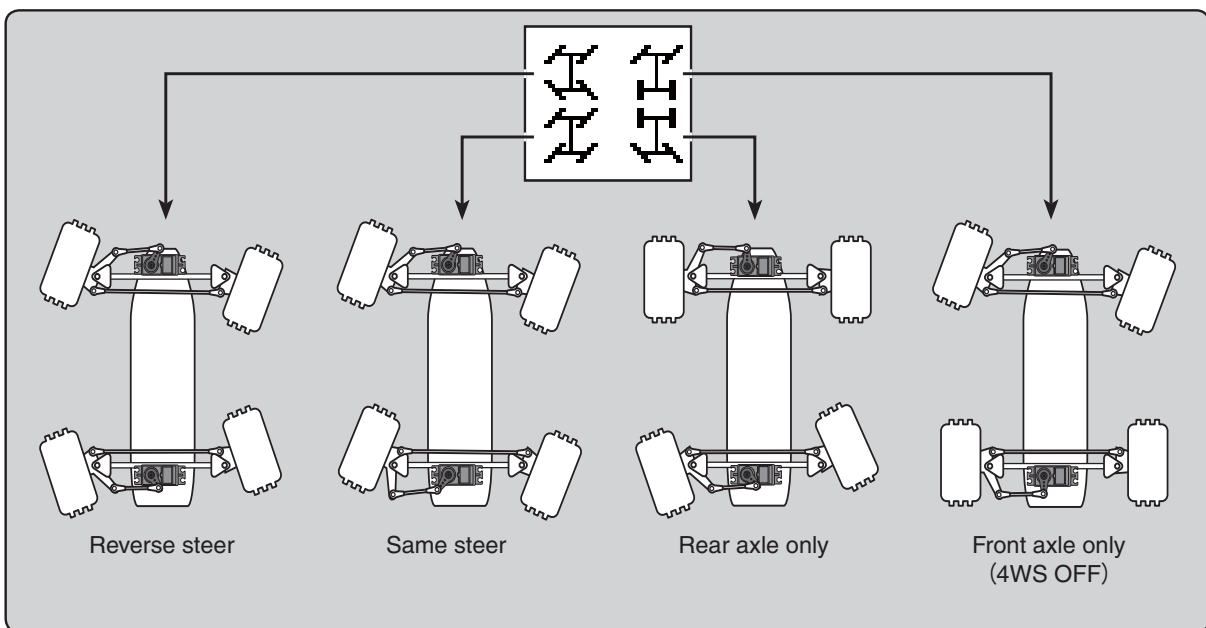
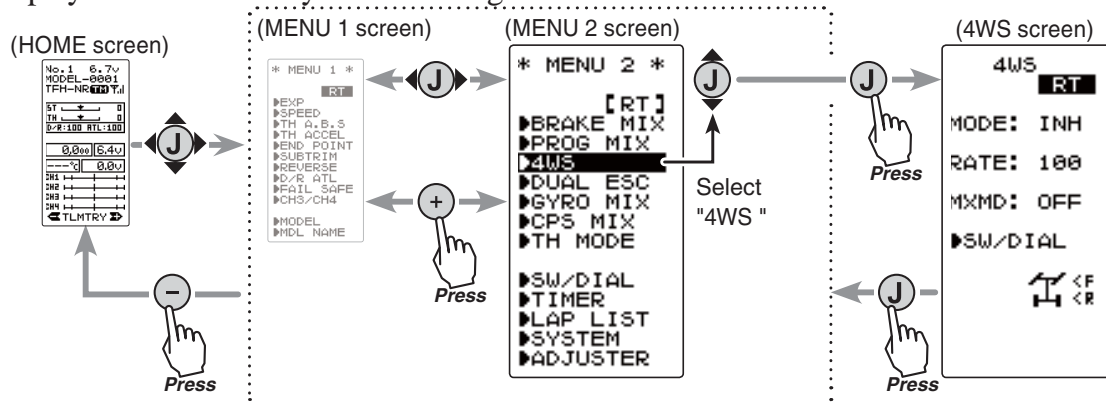

## 4WS mixing adjustment

(Preparation)

Since this function is used by switching the type of 4WS with a switch, the switch used by the function select switch dial function is set.

## Setup items

- MODE : 4WS Type
- RATE : 3ch rate (Rear side)
- MXMD : Mix mode

## Function SW

4WS

Function

# 1 (4WS type selection)

Select the setting item "MODE" using the (JOG) button up or down operation. Use the (+) or (-) and set the function to the "ON" or "OFF" state.

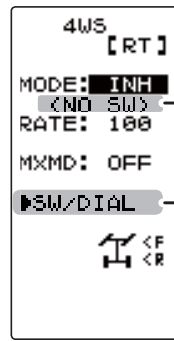

< NO SW >  
If function's ON/OFF switch is not selected, <NO SW> is displayed.

The function select switch screen can be displayed from this screen.

- "INH" :Function OFF (front only)
- "2TYP" :Front axle only, reverse steer switching
- "3TYP" :Front axle only, reverse steer and same steer switching
- "4TYP" :Front axle only, reverse steer, same steer, and rear steer only switching

**Function ON/OFF (MODE)**  
OFF, 2TYP, 3TYP, 4TYP

**Select button**

- Select with the (+) or (-) buttons.

Switched in the order shown in the figure below by set SW

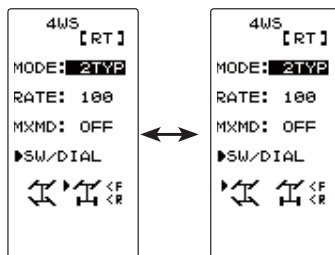

"2TYP" : Front axle only and reverse steer switching

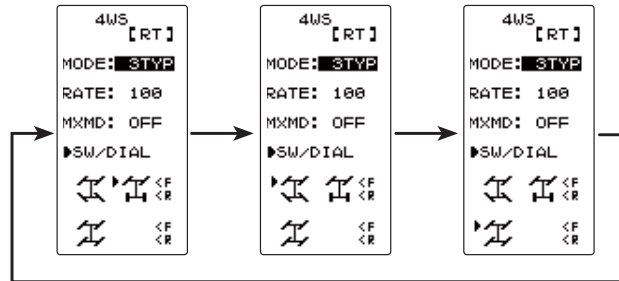

"3TYP" : Front axle only, reverse steer, and same steer switching

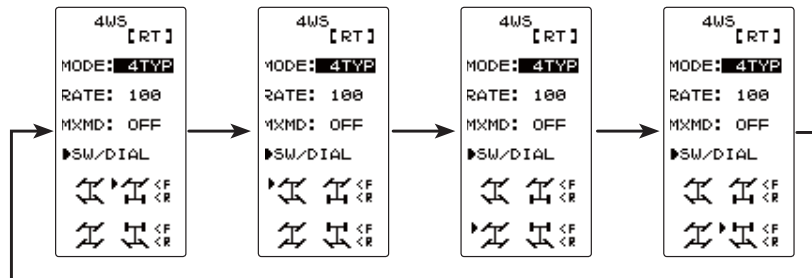

"4TYP" : Front axle only, reverse steer, same steer, and rear axle only switching

# 2 (Rear side travel adjustment)

Select setting item "RATE" using the (JOG) button up or down operation. Adjust the rear axle travel with the (+) or (-) button.

**Rear rate (RATE)**

0 ~ 100  
Initial value:100

**Adjustment buttons**

- Use the (+) and (-) buttons to make adjustments.
- Return to the initial value by pressing the (+) and (-) buttons simultaneously (approx. 1 sec).

# 3 (Mix mode setting)

Select setting item "MXMD" using the (JOG) button up or down operation. Set the mix mode with the (+) or (-) button.

- "OFF" :The EXP function of the 1st CH and other settings are not mixed.
- "ON" :The EXP function of the 1st CH and other settings are mixed.

**Mixing mode (MXMD)**

OFF, ON  
Initial value: OFF

**Select button**

- Select with the (+) or (-) buttons.

# 4

When completed, return to the MENU screen by moving the cursor to the positions other than SW/DIAL and pressing the (JOG) button.



# Dual ESC Mixing "DUAL ESC"

(Throttle system)

This function is mixing used with crawlers and other 4WD type vehicles and uses the 2nd CH to control the front motor controller and the 4th CH to control the rear motor controller.

Front drive only, rear drive only, or both front and rear drive can be selected using any programmed DT (digital trim) button.

## Setting Special mixings

When the 4th CH was set to ACT at Brake Mixing or when CPS Mixing is used, Dual ESC mixing cannot be used.

Display "DUAL ESC" function screen by the following method:

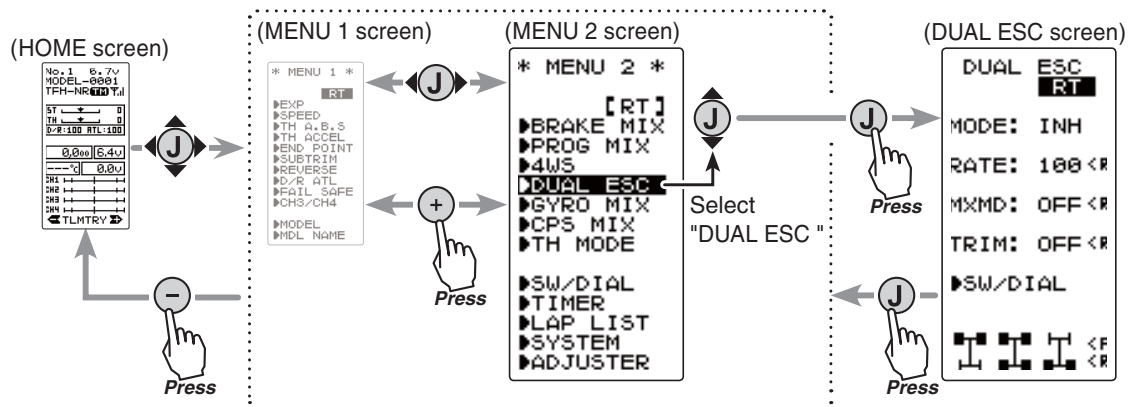

### Setup items

- MODE : Function ON/OFF
- RATE : 4ch rate (Rear side)
- MXMD : Mix mode
- TRIM : Trim mode

## Dual ESC mixing adjustment

(Preparation)

- This function is used to switch between front drive/4WD/rear drive using one of the dials (trim). Set the desired dial (trim) for this function using the SW/DIAL screen.

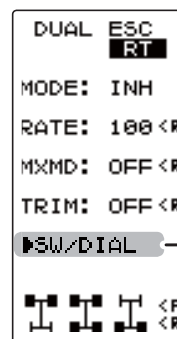

### Function SW

ESC-MD

The function select switch screen can be displayed from this screen.

## 1 (Dual ESC setting)

Select the setting item "MODE" using the (JOG) button up or down operation. Set the function by pressing the (+) or (-) button.

### Function ON/OFF (MODE)

INH, ACT

### Select button

- Select with the (+) or (-) buttons.

"INH" : Function OFF

"ACT" : Function ON



The programmed DT button is used to select the drive type as shown in the figure below.

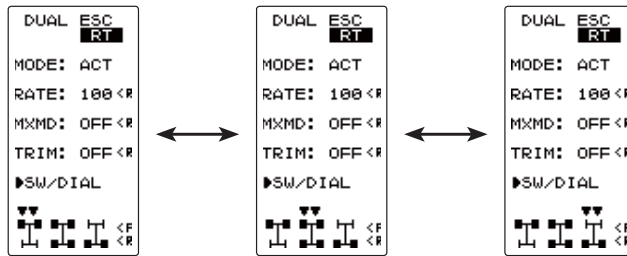

## 2 (Rear drive travel adjustment)

Select the setting item "RATE" by the (JOG) button up or down operation. Use when applying a rotation difference to the front and rear wheels by adjusting the rear (CH4) motor controller travel with the (+) or (-) button.

## 3 (Mix mode setting)

Select the setting item "MXMD" by the (JOG) button up or down operation. Set the mix mode with the (+) or (-) button.

"OFF" : CH2 EXP function and other settings are not mixed.  
 "ON" : CH2 EXP function and other settings are mixed.

## 4 (Trim mode setting)

Select the setting item "TRIM" by the (JOG) button up or down operation. Set the trim mode with the (+) or (-) button.

"OFF" : Front drive (CH2) trim data is not included.  
 "ON" : Front drive (CH2) trim data is included.

**5** When completed, return to the MENU screen by moving the cursor to the positions other than SW/DIAL and pressing the (JOG) button.

### Dial / Trim Setting

The function select dial function can control the 4th channel's ESC (Rear drive) rate (RATE) with digital dial or digital trim, using the function select switch dial function.

#### Note:

As this function drives 2 separate motor controllers simultaneously, a mutual load is applied. Use this function carefully so that the motor controllers are not damaged. Futaba will not be responsible for motor controller, motor, and other vehicle trouble due to use of this function.

#### Rear rate (RATE)

0 ~ 120  
 Initial value: 100

#### Adjustment buttons

- Use the (+) and (-) buttons to make adjustments.
- Return to the initial value by pressing the (+) and (-) buttons simultaneously (approx. 1 sec).

#### Mixing mode (MXMD)

OFF, ON  
 Initial value: OFF

#### Select button

- Select with the (+) or (-) buttons.

#### Trim mode (TRIM)

OFF, ON  
 Initial value: OFF

#### Select button

- Select with the (+) or (-) buttons.

# Gyro Mixing "GYRO MIX"

(Steering system)

This function is a remote gain function which adjusts the sensitivity of the Futaba car rate gyro at the T4GRS side, and is mixing that uses the 3rd CH to adjust the gyro sensitivity.

When using the T4GRS and switching between AVCS and NORMAL modes use SW1 with the function select switch function.

For a description of the car rate gyro mounting method and handling, refer to the rate gyro instruction manual.

## Setting Special mixings

When the 3rd CH was set to ACT at Brake Mixing or when 4WS Mixing is used, Gyro mixing cannot be used.

## Dial / Trim Setting

The gain amount can be adjusted by using the function switch dial function.

Display "GYRO MIX" screen by the following method:

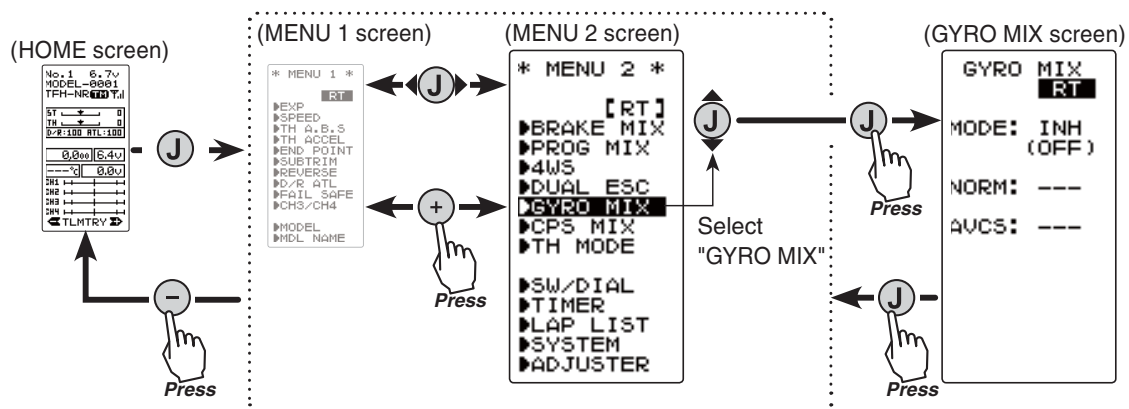

## AVCS / NORMAL Modes

The gyro has 2 operating modes: NORMAL mode and AVCS mode. In the AVCS mode, the angle is controlled simultaneously with NORMAL mode rate control (swing speed). The AVCS mode increases straight running stability more than that of the NORMAL mode. Because the feel of operation is different, choose your favorite mode.

### NORMAL

Countersteers against outside force, but cannot correct the skid direction.

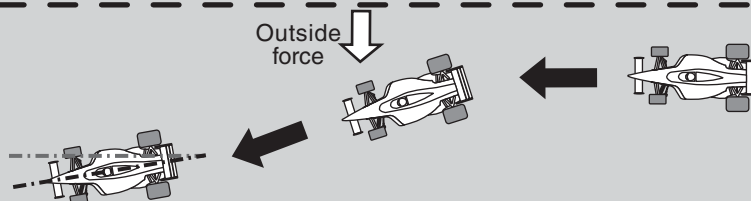

### AVCS

Corrects the skidding direction and forcefully maintains the heading.

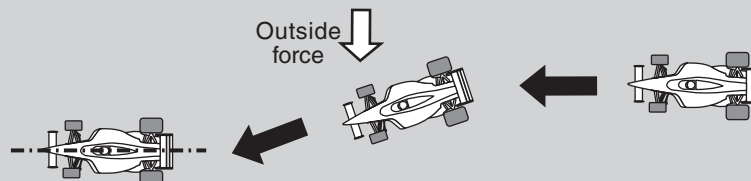

Function

## Gyro mixing adjustment

(Preparation)

- Refer to the gyro instruction manual and connect the gyro to the receiver. When using remote gain, connect gyro sensitivity adjustment to the 3rd CH of the receiver.
- When using gyro mixing by switching between the NORM (normal) and AVCS modes, use the function select switch dial function to set the switch to be used.

### Setup items

MODE : Gyro mode  
 NORM : Normal mode gain  
 AVCS : AVCS mode gain

### Function SW

GYRO  
 SW type  
 ALT

### Function selection (MODE)

INH, NORM, AVCS, SEL

### Select button

- Select with the (+) or (-) buttons.

## 1 (Gyro mixing setting)

Select the setting item "MODE" using the (JOG) button up or down operation. Set the function by pressing the (+) or (-) button.

"INH" : Function OFF  
 "NORM" : NORMAL mode gain  
 "AVCS" : AVCS mode gain  
 "SEL" : Switching Normal mode and AVCS mode  
 (Displayed <NO SW> when the Gyro Mode SW is not used.)

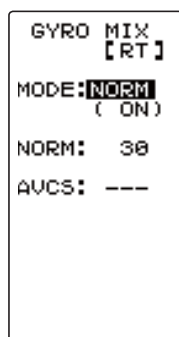

"NORM" mode

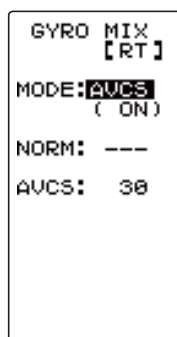

"AVCS" mode

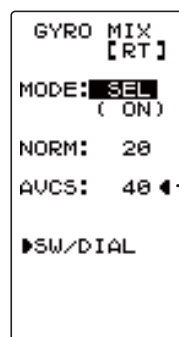

"SELE" mode

Shows the gyro mode select switch mode.

Displayed when the Gyro Mode SW is not used.

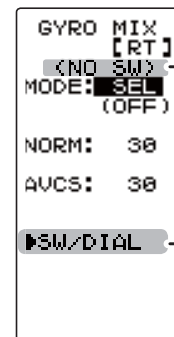

The function select switch screen can be displayed from this screen.

## 2 (NORMAL gain adjustment)

Select the setting item "NORM" using the (JOG) button up or down operation. Adjust the NORMAL gain with the (+) or (-) button.

(AVCS gain adjustment)

Select the setting item "AVCS" using the (JOG) button up or down operation. Adjust the AVCS gain with the (+) or (-) button.

## 3 When completed, return to the MENU screen by moving the cursor to the positions other than SW/DIAL and pressing the (JOG) button.

### NORMAL / AVCS gain (NORM / AVCS)

0 ~ 120  
 Initial value:30

### Adjustment buttons

- Use the (+) and (-) buttons to make adjustments.
- Return to the initial value by pressing the (+) and (-) buttons simultaneously for about 1 second.

Function

# CPS Mixing "CPS MIX"

This function controls the Futaba CPS-1 channel power switch.

Normally, when using the CPS-1 unit to power the vehicle lights etc (LED) the CPS-1 unit with LED connected is connected to a vacant switch channel and the LEDs are turned on and off by the switch while the vehicle is running. However, when the CPS-1 mixing (CPS MIX) function is used, the LED can be turned on and off and flashed in step with steering and throttle operation, as well as being turned on and off by switch. The flashing speed (cycle) can also be set.

For instance, the LED can be flashed as a brake light when the brakes are operated.

## Setting Special mixings

When the 4th CH was set to ACT at Brake Mixing or when Dual ESC Mixing is used, CPS mixing cannot be used.

Display "CPS MIX" screen by the following method:

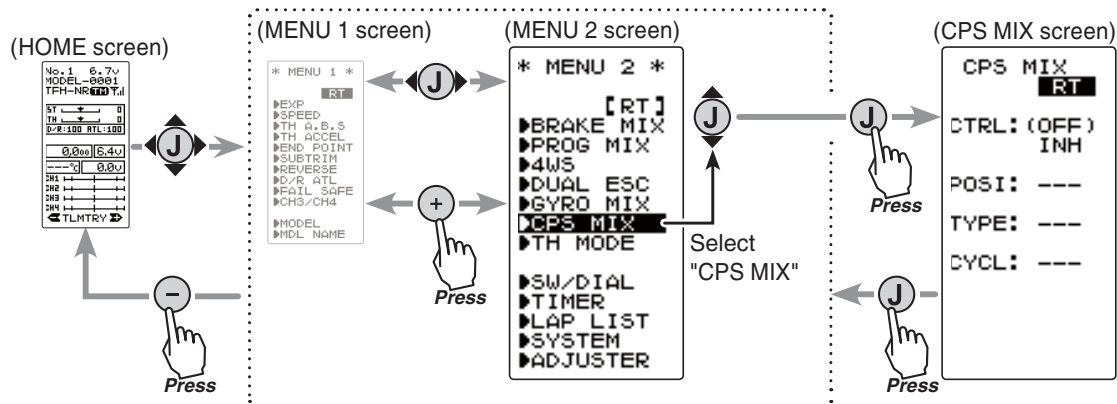

### Setup items

- MODE : Function ON/OFF, control mode
- POSI : ON/OFF position
- TYPE : ON/OFF type
- TCYCL: Flashing speed

## CPS mixing adjustment

(Preparation)

- Connect the CPS-1 to the 4th CH of the receiver.
- When the LEDs are turned on and off by switch, use the function select switch dial function to set the switch to be used.

**Function SW**  
CH4

## 1 (Control system setup)

Operate the (JOG) button up and down and select the setting item "CTRL". Use the (+) or (-) button and select the function.

"INH" : Function OFF  
"CH4 FUNC" : ON/OFF by switch set at the 4th CH  
"STR NT" : ON at steering neutral  
"STR END" : ON at both sides of steering  
"THR NT" : ON at throttle neutral  
"THR FWD" : ON at throttle forward side  
"THR BRK" : ON at throttle back (brake) side  
"TH NT+BK" : ON at throttle neutral and back (brake) sides

### Function selection (MODE)

INH, CH4 FUNC, STR NTR, STR END, THR NT, THR FWD, THR BRK, TH NT+BK

### Select button

- Select with the (+) or (-) buttons.

## 2 (ON/OFF switching position selection)

Select the setting item "POSI" using the (JOG) button up or down operation. Use the (+) or (-) button and select the ON/OFF position. Since the ON/OFF state is displayed at the right side of the setting item "CTRL", setting can be confirmed while operating the function to be controlled (for example, throttle).

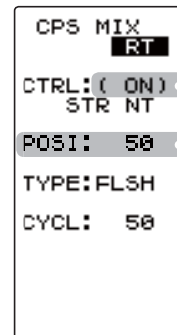

Shows the ON/OFF state

ON/OFF Position (POSI)

5 ~ 95  
Initial value: 50

## 3 (ON/OFF type setup)

Select the setting item "TYPE" using the (JOG) button up or down operation. Use the (+) or (-) button and select the type of LED lighting. Normal ON/Off type or flashing can be selected.

"NORMAL" : Normal ON/OFF type  
"FLASH" : Flashing display

### Function selection (TYPE)

NORMAL, FLASH

### Select button

- Select with the (+) or (-) buttons.

## 4 (Flashing cycle setting)

When flashing type "FLASH" was selected at the setting item "TYPE" the flashing speed (cycle) can be set.

Select the setting item "CYCL" using the (JOG) button up or down operation. Use the (+) or (-) button and select the flashing speed (cycle).

### Flashing cycle (CYCL)

1 ~ 100  
Initial value:50

### Adjust button

- Use the (+) and (-) buttons to make adjustments.  
- Return to the initial value by pressing the (+) and (-) buttons simultaneously for about 1 second.

5 When completed, return to the MENU2 screen by pressing the (JOG) button.



Function

This menu has the following 4 functions:

- Servo neutral mode, which sets the throttle neutral ratio to 7:3 or 5:5
- Idle up, which raises the idling speed when starting the engine to improve engine starting performance of a gasoline car (boat)
- Neutral brake, which applies the brakes at the neutral position of the throttle stick
- Throttle off (engine cut), which stops the engine of a boat, etc. by operating the throttle servo to the low side regardless of the position of the throttle stick.

Display "TH MODE" screen by the following method:

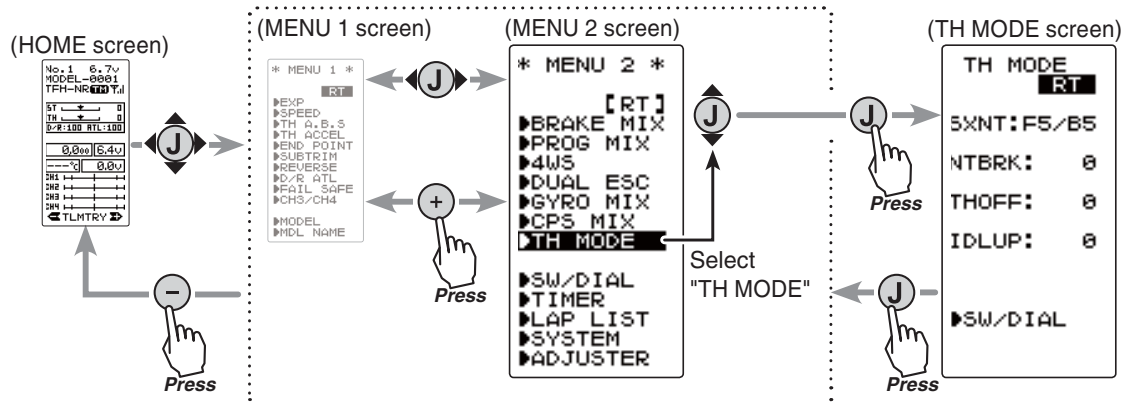

**Setup items**

- SXNT : Throttle servo neutral position
- NTBRK : Neutral brake rate
- IDLUP : Idle-Up rate
- THOFF : Throttle off (engine cut) position

## Throttle servo neutral position "SXNT"

\*This function is not available in "TH-STK : F10 mode".

-This function allows selection of the forward side and brake (reverse) side operation ratio from 7:3 or 5:5 by changing the neutral position of the throttle servo.

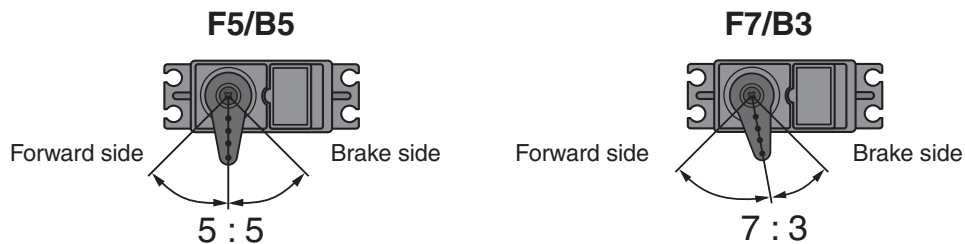

### Selecting the throttle servo neutral position

#### 1 (Mode selection)

Select the setting item "SXNT" by (JOG) button. Select "F5/B5" or "F7/B3" by (+) or (-) button.

- "F5/B5" =Forward 50% : Back50%
- "F7/B3" =Forward 70% : Back30%

**Mode selection (SXNT)**

F5/B5, F7/B3

**Select button**

- Select with the (+) or (-) buttons.

#### 2

When completed, return to the MENU screen by moving the cursor to the positions other than SW/DIAL and pressing the (JOG) button.

Function

## Idle-Up "IDLUP"

This is a function select switch dial function. The idle up switch must be set.

This function is used to improve engine starting performance by raising the idling speed when starting the engine of a gasoline car (boat). It is also effective when you want to eliminate any braking effect when the power is turned off during running, due to the effect of your gear ratio setting and choice of motor when operating an electric car. However, considering safety, and to prevent the motor from rotating instantly when the power was turned on, the MC950CR, MC851C, MC602C, MC402CR, and other Futaba MC (Motor Controllers) will not enter the operation mode if the neutral position is not confirmed. When using the MC950CR, MC851C, MC602C, MC402CR, or other Futaba MC, confirm that the MC is in the neutral position and the set is in the operation mode before setting the idle up function switch to ON.

### Operation

The throttle neutral position is offset to the forward side. There is no linkage locking, etc. because there is no change near the maximum operation angle even when the neutral position is offset by this function.

### Operation Display

While this function is ON, the LED blinks.

< NO SW >  
 If function's ON/OFF switch is not selected, <NO SW> is displayed.

The function select switch dial screen can be displayed from this screen.

```

            TH MODE
            [ RT ]
            SXNT: F5/B5
            NTBRK: 0
            THOFF: 0
            IDLUP: 0
            (NO SW)
            SW/DIAL
        
```

If the power switch is turned on while the idle-up switch is on, an audible alarm will be heard. Immediately set the Idle-Up switch to OFF.

WARNING

MIX WARN

IDLE UP

OF

THOFF

OF

NEUTRAL BRAKE

Warning display

### Idle-Up function adjustment

(Preparation)

- Use the function select switch dial to select the switch.

#### 1 (Idle-Up rate)

Select the setting item "IDLUP" using the (JOG) button. Use the (+) and (-) buttons to set the Idle-Up rate.

**2** When completed, return to the MENU screen by moving the cursor to the positions other than SW/DIAL and pressing the (JOG) button

### Dial / Trim Setting

The function select dial function can control the Idle-up rate with digital dial or digital trim.

#### Adjust button

- Adjust with the (+) and (-) buttons.
- Return to the initial value "0" by pressing the (+) and (-) buttons simultaneously for about 1 second.

#### Idle-Up rate (IDLUP)

D50 ~ D1, 0, U1 ~ U50

Initial value: 0  
 "D": Brake side  
 "U": Forward side

# Neutral Brake "NTBRK"

\*This function is not available in "TH-STK : F10 mode".

This is a function select switch dial function. The neutral brake function ON/OFF switch must be set.

The neutral brake, which applies the brakes at the neutral position of the throttle stick, can be set. However, when using the MC950CR, MC851C, MC602C, MC402CR, or other Futaba MC (Motor Controller), confirm that the MC is in the neutral position and the set is in the operation mode before setting the neutral brake function switch to ON, the same as the idle up function. In addition, when the idle up function or throttle off function is set, these functions have a higher priority than the neutral brake function.

## Reference

The ESC neutral brake function and T4GRS neutral brake function can be used simultaneously. However, when setting is difficult to understand, we recommend that only one neutral brake function be used.

## Dial / Trim Setting

When the neutral brake function is "ON", the neutral brake rate adjustment is automatically assigned to the throttle trim (DT1/2/3/4 or DL1).

## Operation display

An LED blinks while the neutral brake function is active.

The diagram illustrates the function select screen and a warning display. The function select screen shows the following menu items: TH MODE [RT], SXNT: F5/B5, NTBRK: 0, THOFF: 0, IDLUP: 0, <NO SW>, and SW/DIAL. Two text boxes provide instructions: one states that if the function's ON/OFF switch is not selected, <NO SW> is displayed; the other states that the function select switch screen can be displayed from this screen. A warning display shows a 'WARNING' icon, 'MIX WARN', 'IDLE UP', 'THOFF', and 'NEUTRAL BRAKE'. A text box explains that if the power switch is turned on while the neutral brake switch is on, an audible alarm will be heard, and the neutral brake switch should be set to OFF.

## Neutral Brake function adjustment

(Preparation)

- Use the function select switch dial to select the switch.

### 1 (Neutral brake rate)

Select the setting item "NTBRK" using the (JOG) button. Use the (+) and (-) buttons to set the neutral brake rate.

### 2

When completed, return to the MENU screen by moving the cursor to the positions other than SW/DIAL and pressing the (JOG) button

## Adjust button

- Adjust with the (+) and (-) buttons.
- Return to the initial value "0" by pressing the (+) and (-) buttons simultaneously for about 1 second.

## Brake rate (NTBRK)

0 ~ B100  
Initial value: 0

## Effect of set value of other functions on neutral brake

Throttle side EPA function, or ATL function setting, also affects neutral brake side operation.



# Throttle Off (engine cut) "THOFF"

This is a function select switch dial function. The throttle off function ON/OFF switch must be set. The engine cut function stops the engine of a boat, etc. by operating the throttle servo to the slow side by switch regardless of the position of the throttle stick and the setting of other functions (reverse function setting is effective).

## Dial / Trim Setting

The function select dial function can control the throttle-off position can be controlled with digital dial or digital trim.

## Operation display

An LED blinks while the neutral brake function is active.

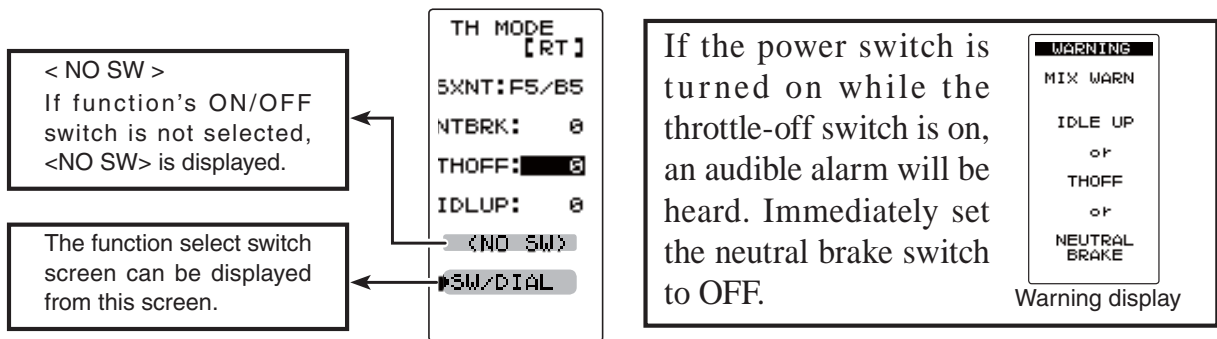

## Engine Cut function adjustment

(Preparation)

- Use the function select switch dial to select the switch.

### 1 (Preset position setup)

- Select the setting item "THOFF" using the (JOG) button. Use the (+) and (-) buttons to set the preset position of the throttle servo.

#### Adjust button

- Adjust with the (+) and (-) buttons.
- Return to the initial value by pressing the (+) and (-) buttons simultaneously (approx. 1 sec).

### 2 When completed, return to the MENU screen by moving the cursor to the positions other than SW/DIAL and pressing the (JOG) button

#### Preset position (THOFF)

0 ~ B100  
Initial value: 0

Function

## ⚠ Caution

### ⓘ Always check carefully before using this function.

While switch with preset function set is in the ON state, the servo (motor controller) is locked in the preset position and does not operate even if the throttle stick is operated. If the servo was operated at the wrong setting, you may lose control of the car (boat).

# ESC Link Function "MC LINK"

This is a special function which lets you set the contents of the Link software in Futaba speed controller (ESC), MC960CR, MC940CR, MC950CR, MC851C, MC602C, MC402CR, etc, with variable frequency and other data changes at the T4GRS transmitter. However, some data changes require a PC and Link software. This function is used by connecting ESC directly to the transmitter. The T4GRS power switch is set to the display side. Use the various optional servo extension cords according to the distance between the transmitter and ESC. The last data read from ESC to T4GRS or the last data written from T4GRS to ESC is saved to the T4GRS. Since the data for each model memory can be saved, the data of up to 40 models can be saved.

-When the T4GRS battery voltage drops, the display switches to low battery display. Therefore, use this function when there is ample battery capacity remaining.

-Also connect the battery at the ESC side.

-**Note:** Do not read to the T4GRS an MC940/960CR whose speed was set to over 99990rpm by Link software side Boost Angle rpm setting.

## Connection diagram

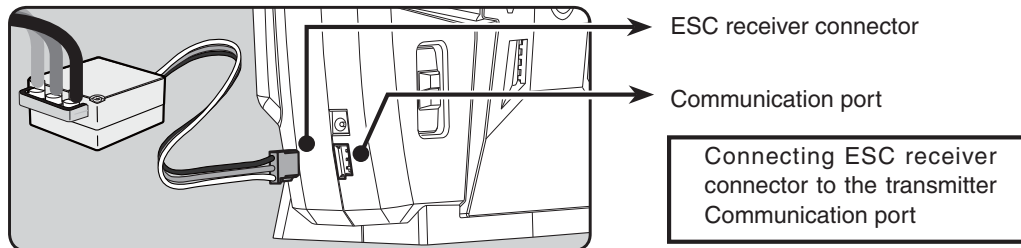

(DISP MENU screen)

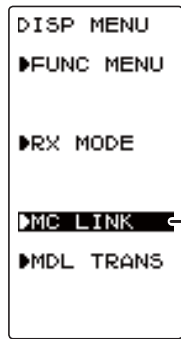

(MC LINK screen)

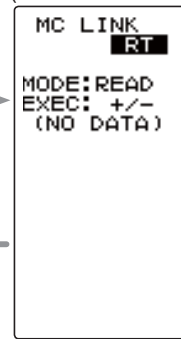

<p>MC LINK [RT]</p> <p>MODE: READ EXEC: +/- (MC402CR)</p> <p>MIN: 3.0   CLH: 300 MAX: 2.5   CTH: 300 BRK: 5PH DLT: 0 DBR: 15 BND: 100 LBP: 3.0 RND: 50 NTB: 0   FNB: 28</p> <p>MC402CR</p>	<p>MC LINK [RT]</p> <p>MODE: READ EXEC: +/- (MC602C)</p> <p>MIN: 3.0   CLH: OFF MAX: 1.5   CTH: 300 BRK: HIG DLT: 0 DBR: 12 BND: 100 LBP: 3.0 NTB: 0   FNB: 3</p> <p>MC602C</p>	<p>MC LINK [RT]</p> <p>MODE: READ EXEC: +/- (MC851C)</p> <p>MIN: 3.0   CLH: 300 MAX: 2.5   CTH: 300 BRK: HIG DLT: 0 DBR: 12 BND: 100 LBP: 3.0 NTB: 0   FNB: 0</p> <p>MC851C</p>	<p>MC LINK [RT]</p> <p>MODE: READ EXEC: +/- (MC950CR)</p> <p>MIN: 5.0   CLH: OFF MAX: 3.0   REV: BRK BRK: 1.5   LA: 0 DBR: 8 BND: 100 LBP: 2.5   RND: 100 NTB: 2   FNB: 6</p> <p>MC950CR</p>
--	---	---	--

<p>MC LINK [RT]</p> <p>MODE: READ EXEC: +/- (MC960CR)</p> <p>MIN: 5.0   CLH: OFF MAX: 3.0   REV: BRK BRK: 1.5   BND: 100 DBR: 8   RND: 100 LBP: 2.8   RLS: 0 NTB: 0   SEC: 6.0 TSH: OFF P2 →</p> <p>MC960CR</p>	<p>MC LINK [RT]</p> <p>MODE: READ EXEC: +/- (MC940CR)</p> <p>MIN: 5.0   CLH: OFF MAX: 3.0   REV: BRK BRK: 1.5   BND: 100 DBR: 8   RND: 100 LBP: 2.8   RLS: 0 NTB: 0   SEC: 6.0 TSH: OFF P2 →</p> <p>MC940CR</p>
---	---

## Using the ESC Link function

(Preparation)

-Connect the T4GRS and ESC in accordance with the connection diagram, and connect the battery to ESC.

**1** Set the transmitter power switch to the display side (DISP).  
Display the MC LINK screen in the above manner.

**2** (ESC read)

Execute this function to read the connected ESC type and the data currently set at the amp. To save the ESC data to the T4GRS, rewrite the read data.

When you want to write the data saved in the T4GRS to an ESC of the same type, execute the following "WRITE"(write) without executing "READ"(read).

**a** -Select the setting item "MODE" using the (JOG) button, and select "READ" by (+) or (-) button.

**b** -Select the setting item "EXEC:+/-" using the (JOG) button, and press the (+) and (-) buttons simultaneously for 1 second or longer.

- "COMPLETE!" blinks on the screen and the ESC type and currently set contents are read.

- If "LINK ERROR" blinks on the screen, communication with the amp is not being performed normally. Check the T4GRS and ESC connection and the battery connection to ESC and the ESC power switch and repeat steps a→b.

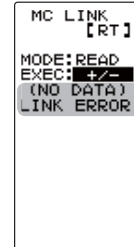
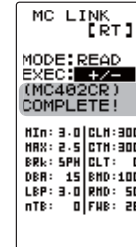
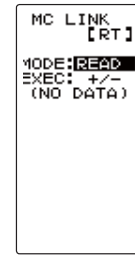

### 3 (Writing to ESC)

Execute this function to write the setting data to ESC.

**a** -Select the setting item "MODE" using the (JOG) button, and select "WRITE" by (+) or (-) button.

**b** -Select the setting item "EXEC:+/-" using the (JOG) button, and press the (+) and (-) buttons simultaneously for 1 second or longer.

- "COMPLETE!" blinks on the screen and the setting data is written to ESC.

If "LINK ERROR" blinks on the screen, communication with the amp is not being performed normally. Check the T4GRS and ESC connection and the battery connection to ESC and the ESC power switch and repeat steps a→b. In addition, if (NO DATA) is displayed on the T4GRS screen, "WRITE" cannot be selected because there is no setting data to be written.

- Different type ESC data cannot be written. If writing is attempted, "TYPE ERROR" will link on the screen to show that the ESC type is wrong.

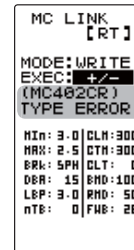
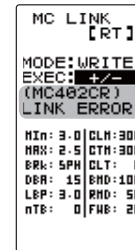
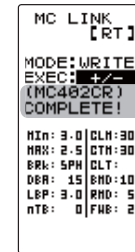

### 4 (Initialization)

This function writes the MC setting data set at the factory to the connected MC and T4GRS. Perform "READ" before performing initialization.

**a** -Select the setting item "MODE" using the (JOG) button, and select "RESET" with the (+) or (-) button.

**b** -Select the setting item "EXEC:+/-" using the (JOG) button, and press the (+) and (-) buttons simultaneously for approximately 1 second

- "COMPLETE!" blinks on the screen and the initial data is written to the ESC.

If "LINK ERROR" blinks, communication with the amp was not performed normally. Check the T4GRS and ESC connection and the battery connection to ESC and the ESC power switch, and repeat steps a→b. In addition, when (NO DATA) is displayed on the T4GRS screen "RESET" cannot be selected because there is no written initial data.

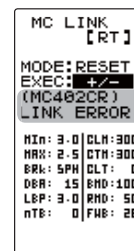

Function

## ESC function setup (MC601/602/850/851C, 401/402/950CR)

- 1 Select the setting item using the (JOG) button.  
Set the value by (+) and (-) button.

### Setup item selection

- Select by the (JOG) button.

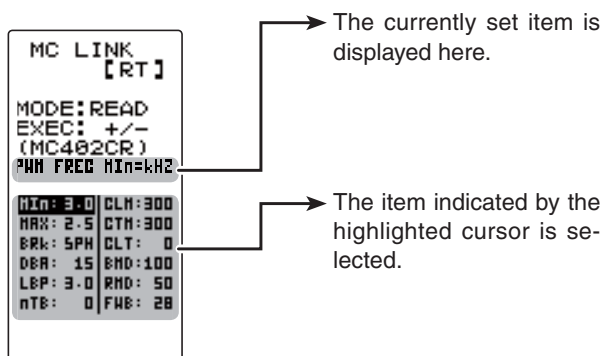

### Adjustment buttons

- Use the (+) and (-) buttons to make adjustments.
- Return to the initial value by pressing the (+) and (-) buttons simultaneously (approx. 1 sec).

### Setup item

#### Min-(PWM FREQ MIN LD) 100Hz~10000Hz (10kHz)

MC950CR:500Hz~30000Hz (30kHz)

Same as Link software PWM frequency (at Min. load),  
Min sets the "0"A PWM frequency at minimum load.

#### MAX-(PWM FREQ MAX LD) 100Hz~10000Hz (10kHz)

MC950CR:500Hz~30000Hz (30kHz)

Same as Link software PWM frequency (at Max. load).  
MAX sets the PWM frequency at maximum load at the output current limit value set by Current Limiter.

#### BRK-(PWM FREQ BRK LD) nOR(2000Hz)/ HIG(1000Hz)/ SPH(500Hz)

MC950CR:500Hz~30000Hz (30kHz)

Same as Link software Brake PWM at frequency.  
This setting can set the brake PWM frequency.

#### nTB-(NEUTRAL BRAKE) 0%(OFF)~100%

Same as Link software Neutral Brake.

Use this setting when you want to use the brakes at the neutral throttle (OFF) position by throttle operation. The larger this value, the greater the braking force. When you want to use the neutral brake, set this value to "0%".

#### CLM-(CURRENT LIMIT) 50A~300A (MC950CR:50A~300A), OFF Same as Link software Current Limiter.

Current Limiter sets the current value at maximum load here.

Since setting of the MAX is based on the output current limit value set by Current Limiter, Current Limiter does not have to be turned OFF except when a current exceeding 300A is generated.

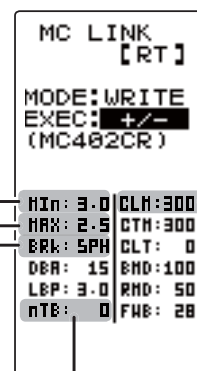

"Min" which sets the frequency when the load is small, is set to the high frequency side (large value) when extension is desired after straight-away and curves.

"MAX" which sets the frequency when the load is large, is set to the high frequency side (large value) when you want to suppress the rise from low speed and when motor heating and commutator roughness are sensed.

When the rise from low speed is poor, and becomes bad even when "MAX" is set to the low frequency side, use the log data to check if there was a momentary voltage drop. When you want to suppress the overall power, lengthen the run time, and otherwise improve efficiency, set both "MAX" and "Min" to the high frequency side. When you want to set a fixed PWM frequency at full range regardless of the load current, set PWM frequency (at Max. load) and PWM frequency (at Min. load) to the same value.

**LBP-(LOW BATTERY VOLT) 2.5V~6V  
2.5V~7.5V for MC950CR**

Same as Link software Low Bat Protection  
This setting cuts off the output to the motor when the main battery voltage drops to the set voltage. This stops the receiver ceasing operation when the power to the receiver becomes insufficient whilst running due to a drop in the power supply voltage. When the power supply voltage recovers, power is supplied to the motor once more.

**DBA-(DEAD BAND) ±2µs~±50µs**

Same as Link software Dead Band.  
This sets the range (neutral point range) over which the ESC does not respond to transmitter throttle operation. The larger the set value, the wider this range.

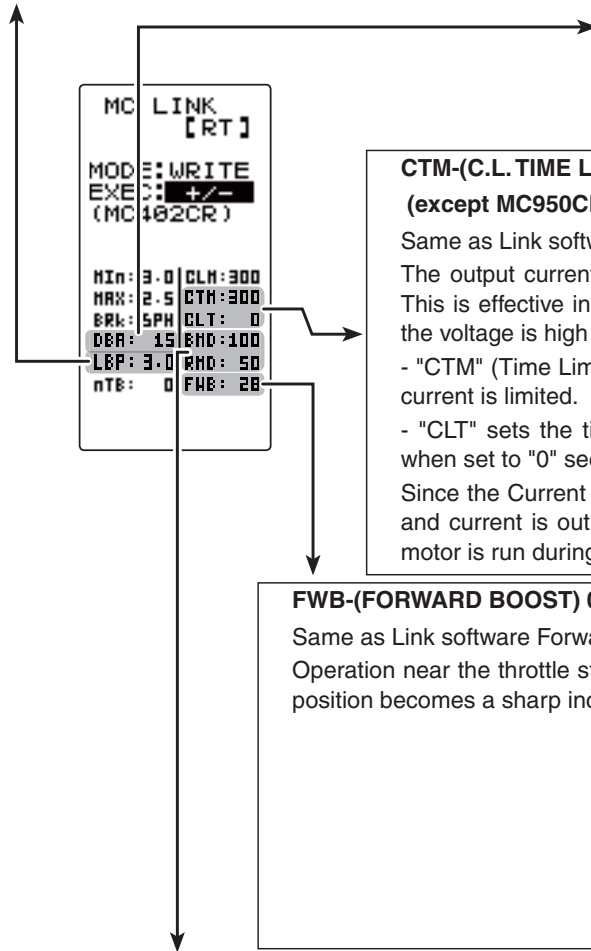
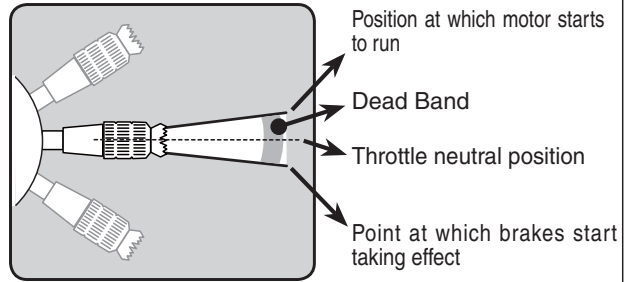

**CTM-(C.L. TIME LIMIT) 50A~300A /CLT-(C.L. TIMER) 0sec(OFF)~240sec  
(except MC950CR)**

Same as Link software Current Limiter (Time Limit)/Current Limit timer.  
The output current can be limited up to a set time from the start of running. This is effective in preventing the motor from outputting wasted energy when the voltage is high immediately after the power battery was recharged.  
- "CTM" (Time Limit) sets the maximum output current for the time the output current is limited.  
- "CLT" sets the time the output current is limited. This function is disabled when set to "0" sec.  
Since the Current Limit Timer starts when the throttle stick is pushed forward and current is output to the motor, this function begins to operate when the motor is run during trim adjustment, etc.

**FWB-(FORWARD BOOST) 0~100 (except MC850C)**

Same as Link software Forward Boost  
Operation near the throttle stick (stick) neutral position becomes a sharp increase.

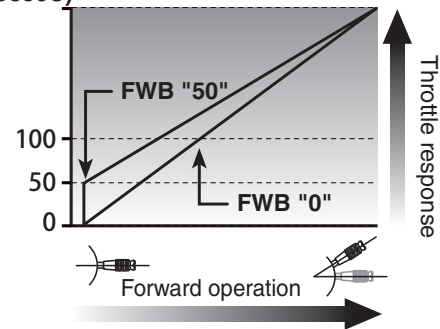

**BMD-(BRAKE MAX DUTY) 0%~100%**

Same as Link software Brake Max. Duty.  
This setting can set the braking force between the neutral point and Max brake point. The larger this value, the greater the braking force. When set to "0%", the brakes are not effective.

**RMD-(REVERSE MAX DUTY) w/back only 0%~100%**

Same as Link software Reverse Max. Duty  
This setting can set the reverse power between the neutral point and Max reverse point. The larger this value, the greater the reverse power. When set to "0%", reverse is not effective.

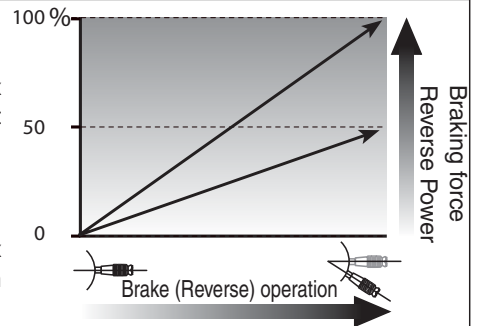

**MC950CR only setup item**

```

MIN: 5.0 | CLH: OFF
MAX: 3.0 | REV: BRK
BRk: 1.5 | LA: 0
DBA: 8 | RMD: 100
LBP: 2.5 | RND: 100
nTB: 2 | FWB: 6
    
```

**REV-(REV CANCEL) BRk /REV** Same as Link software Reverse Cancel.

When set to BRk, reverse operation is disabled.

**LA-(LEAD ANGLE) 0~1500** Same as Link software Lead Angle.

The lead angle of the motor can be set at the MC950CR side. However, we recommend that it is normally "0". Since this setting is based setting by referring to the speed log by the Link software, independent use of the MC LINK function of the T4GRS is recommended.



**Function**

## ESC function setup (MC940CR, MC960CR)

- Select the setting item using the (JOG) button.  
Set the value by (+) and (-) button.  
Operate the following (JOG) button and switch between Page1 and Page2 of the setup screen.

### Setup item selection

- Select by the (JOG) button.

### Adjustment buttons

- Use the (+) and (-) buttons to make adjustments.
- Return to the initial value by pressing the (+) and (-) buttons simultaneously (approx. 1 sec).

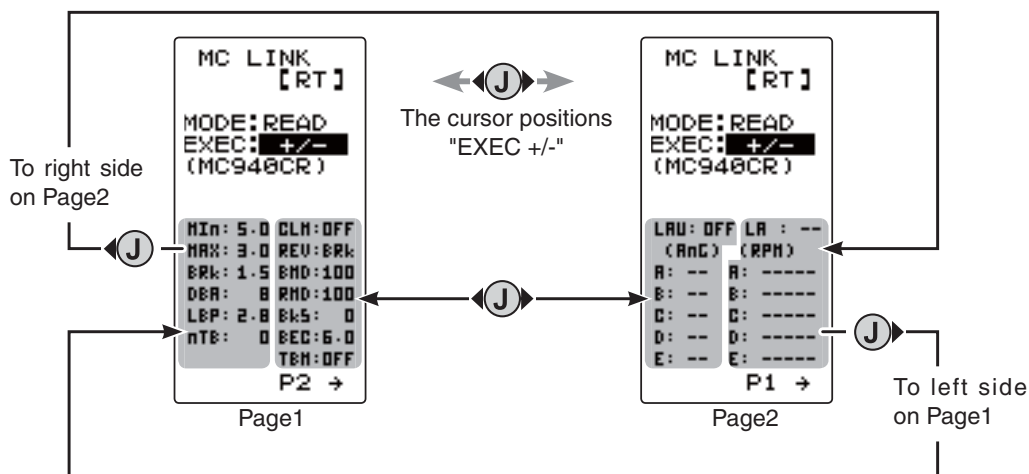

### Setup item

#### Min-(PWM FREQ MIN LD) 1kHz(1000Hz)~30kHz (30000Hz)

Same as Link software PWM frequency (at Min. load), Min sets the "0"A PWM frequency at minimum load.

#### MAX-(PWM FREQ MAX LD) 1kHz(1000Hz)~30kHz (30000Hz)

Same as Link software PWM frequency (at Max. load). MAX sets the PWM frequency at maximum load at the output current limit value set by Current Limiter.

#### BRK-(PWM FREQ BRK LD) 1kHz(1000Hz)~30kHz (30000Hz)

Same as Link software Brake PWM at frequency. This setting can set the brake PWM frequency.

#### nTB-(NEUTRAL BRAKE) 0%(OFF)~100%

Same as Link software Neutral Brake. Use this setting when you want to use the brakes at the neutral throttle (OFF) position by throttle operation. The larger this value, the greater the braking force. When you want to use neutral brake, set this value to "0%".

#### CLM-(CURRENT LIMIT) 50A~500A

Same as Link software Current Limiter. Current Limiter sets the current value at maximum load here. Since setting of the MAX is based on the output current limit value set by Current Limiter, Current Limiter does not have to be turned OFF except when a current exceeding 300A is generated.

### Page1

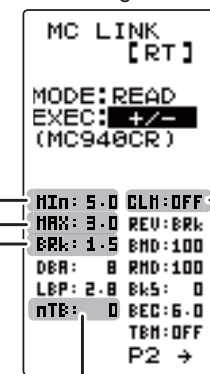

Function

"Min" which sets the frequency when the load is small, is set to the high frequency side (large value) when extension is desired after straight-aways and curves.

"MAX" which sets the frequency when the load is large, is set to the high frequency side (large value) when you want to suppress the rise from low speed and when motor heating and commutator roughness are sensed.

When the rise from low speed is poor, and becomes bad even when "MAX" is set to the low frequency side, use the log data to check if there was a momentary voltage drop. When you want to suppress the overall power, lengthen the run time, and otherwise improve efficiency, set both "MAX" and "Min" to the high frequency side. When you want to set a fixed PWM frequency at full range regardless of the load current, set PWM frequency (at Max. load) and PWM frequency (at Min. load) to the same value.

**LBP-(LOW BATTERY VOLT) 2.5V~7.5V**  
 Same as Link software Low Bat Protection  
 This setting cuts off the output to the motor when the main battery voltage drops to the set voltage. This stops the receiver ceasing operation when the power to the receiver becomes insufficient whilst running due to a drop in the power supply voltage. When the power supply voltage recovers, power is supplied to the motor once more.

```

MC LINK
[RT]

MODE: READ
EXEC: +/-
(MC948CR)

Min: 5.0 CLM: OFF
MAX: 3.0 REV: BRK
BRK: 1.5 BND: 100
DBA: 8 RND: 100
LBP: 2.8 Bk5: 0
nTB: 0 BEC: 6.0
TBM: OFF
P2 →
    
```

Page1

**DBA-(DEAD BAND) ±2µs~±50µs**  
 Same as Link software Dead Band.  
 This sets the range (neutral point range) over which the ESC does not respond to transmitter throttle operation.  
 The larger the set value, the wider this range.

**REV-(REV CANCEL) BRk / REV**  
 Same as Link software Reverse Cancel.  
 When set to BRk, reverse operation is disabled.

**BMD-(BRAKE MAX DUTY) 0%~100%**  
 Same as Link software Brake Max. Duty.  
 This setting can set the braking force between the neutral point and Max brake point. The larger this value, the greater the braking force. When set to "0%", the brakes are disabled.

**RMD-(REVERSE MAX DUTY) w/back only 0%~100%**  
 Same as Link software Reverse Max. Duty  
 This setting can set the reverse power between the neutral point and Max reverse point. The larger this value, the greater the reverse power. When set to "0%", reverse is disabled.

```

MC LINK
[RT]

MODE: READ
EXEC: +/-
(MC948CR)

Min: 5.0 CLM: OFF
MAX: 3.0 REV: BRk
BRk: 1.5 BND: 100
DBA: 8 RND: 100
LBP: 2.8 Bk5: 0
nTB: 0 BEC: 6.0
TBM: OFF
P2 →
    
```

Page1

**BKS-(BRAKE SLOPE) 0~300 (Only when used TBM-LEV2)**  
 Same as Link software Brake Slope.  
 This function adjusts the braking effect when the throttle is returned (throttle off). It eliminates the effect known as "engine braking" in full sized vehicles.

**BEC-(BEC VOLT) 6.0V / 7.4V**  
 Same as Link software BEC Volt.  
 The receiver BEC voltage can be selected from 6.0V and 7.4V. Match the voltage to the rating of the servo connected to the same receiver. This BEC voltage cannot output a voltage higher than the input voltage.

Function

```

MC LINK
[RT]

MODE:READ
EXEC: +/-
(MC940CR)

MIN: 5.0 CLM:OFF
MAX: 3.0 REV:BRK
BRK: 1.5 BMD:100
DBA: 8 RND:100
LEP: 2.8 Bk5: 0
nTB: 0 BEC:6.0
TBM:OFF
P2 →

```

Page1

### TBM-(TURBO MODE) OFF /LV1 /LV2

Same as Link software Turbo Mode

This function sets the turbo mode. More power can be enabled using the turbo mode. Depcompleted on the setting, the motor and ESC may be damaged so use this setting carefully.

(Note) When LAU (LEAD ANGLE USE) is off, lead angle setting will not operate even if set to LEV1 or LEV2. (Turbo mode disabled, TBM=OFF)

#### OFF mode: (No Lead Angle mode) Lead angle - No

When used in races in which the lead angle setting function is inhibited by ESC, set to this mode. The lead angle function is disabled in the same manner as if LAU (LEAD ANGLE USE) was turned off.

When the lead angle function is disabled by the method described above, the MC960CR shows that the lead angle function is off by flashing a blue LED at an ON 0.1 second, OFF 0.9 second cycle at the neutral point.

#### LV1 turbo mode: (Lead Angle mode) Lead angle – Yes

The output can be increased by setting a lead angle.

Depcompleted on the set value, the motor may be damaged so increase the lead angle value in steps from a small value while observing the result.

Turn on LAU (Lead Angle Use) and adjust the lead angle by LA-(LEAD ANGLE) and A, B, C, D, E BA-(A, B, C, D, E BOOST ANGLE) value.

#### LV2 power mode: (Power Mode) Lead angle – Yes

Displays still more power than a turbo.

However, since even a motor applies a large load on the ESC, make the lead angle larger in steps from a small value while observing the result.

Turn on LAU (LEAD ANGLE USE) and adjust the lead angle by LA-(LEAD ANGLE) and A, B, C, D, E BA-(A, B, C, D, E BOOST ANGLE) value.

Function

When "LAU" (LEAD ANGLE USE) is turned on "LA" (LEAD ANGLE) is the lead angle can be set. In addition, the "BOOST ANGLE" and "BOOST ANGLE RPM" can be set.

```

MC LINK
[RT]

MODE:READ
EXEC: +/-
(MC940CR)
LEAD ANGLE USE

LAU: OFF ==
(RnG) (RPM)
A: -- A: -----
B: -- B: -----
C: -- C: -----
D: -- D: -----
E: -- E: -----
P1 →

```

Page2

"LAU" turned on

```

MC LINK
[RT]

MODE:READ
EXEC: +/-
(MC940CR)
LEAD ANGLE USE

LAU: On LA : 0
(RnG) (RPM)
A: 0 A: 0
B: 0 B: 0
C: 0 C: 0
D: 0 D: 0
E: 0 E: 0
P1 →

```

Page2

"LA" (LEAD ANGLE) is displayed and the lead angle can be set.

The BOOST ANGLE and BOOST ANGLE RPM which can set the lead angle of 5 points relative to the speed.



```

MC LINK
[RT]

MODE: READ
EXE: +/-
(MC940CR)
LEAD ANGLE USE

LAU: On LA: 0
(RnC) (RPM)
A: 0 A: 0
B: 0 B: 0
C: 0 C: 0
D: 0 D: 0
E: 0 E: 0
P1 →

```

Page2

**LAU-(LEAD ANGLE USE) ON/OFF**  
Same as Link software Lead Angle Use

This function is effective when TBM (Turbo Mode) is LEV1 or LEV2 and sets whether or not lead angle is used. This setting has priority over the TURBO MODE setting. When using in races in which the lead angle function is inhibited by the ESC set this function to OFF.

OFF : Lead angle function not used.  
ON : Lead angle used

**LA-(LEAD ANGLE) 0~59 deg**  
Same as Link software Lead Angle

When LAU (LEAD ANGLE USE) is turned on the motor lead angle can be set at the MC960CR. The lead angle can be set up to 59 degrees in 1 degree increments.

**A,B,C,D,E BA-(A,B,C,D,E BOOST ANGLE) 0~59 deg**  
Same as Link software Boost Angle

**A,B,C,D,E RPM-(A,B,C,D,E BOOST ANGLE RPM) 0~99990 rpm**  
Same as Link software Boost Angle rpm

When LAU (LEAD ANGLE USE) is turned on the lead angle versus motor speed of the 5 points A to E can be set. The lead angle can be set up to 59 degrees in 1 degree increments.

**Note:** Do not read to the T4GRS an MC940/960CR whose speed was set to over 99990rpm by Link software side Boost Angle rpm setting.

The LA-(LEAD ANGLE) and A, B, C, D, E BA- (A, B, C, D, E BOOST ANGLE) relationship is shown on the graphs below. Graph [A] shows the relationship when the same value is set at points A, B, C, D, E BA- (A, B, C, D, E BOOST ANGLE) of [A] and [B] and the LA-(LEAD ANGLE) was set to "0" and graph [B] shows the relationship when a value other than "0" was set at LA-(LEAD ANGLE).

As shown in the graphs, [B] is added to the A, B, C, D, E BA-(A, B, C, D, E BOOST ANGLE) set lead angle and [A] is added to the LA-(LEAD ANGLE) set lead angle. For example, if "3" is set at ABA and LA of [B] is set to "2", the actual ABA becomes 3+2=5 (deg). Since LA of [A] is "0", the actual ABA also becomes 3+0=3 (deg).

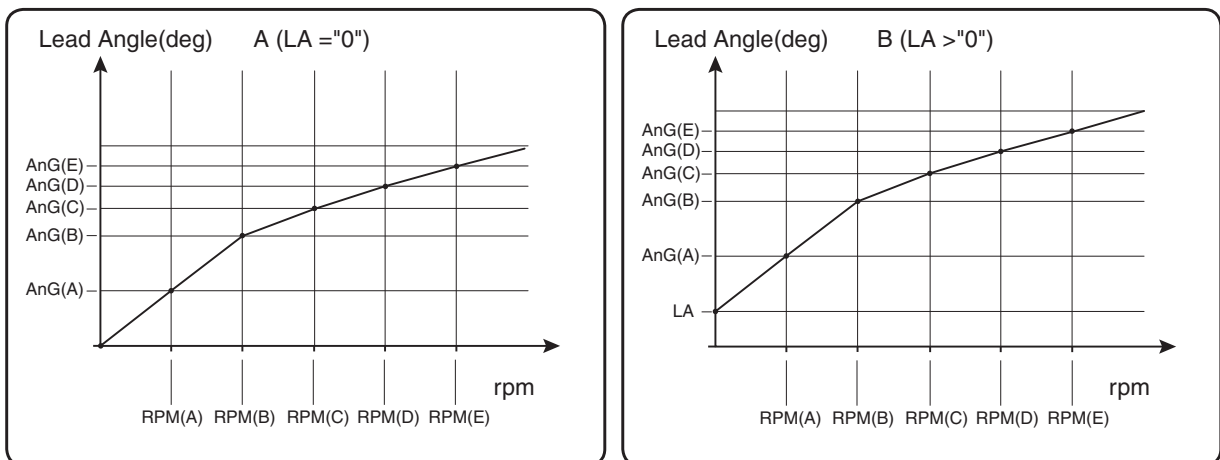

When using in races in which the lead angle setting function is inhibited by the ESC, set LAU (LEAD ANGLE USE) to OFF. The LAU setting has priority over TBM-(TURBO MODE). If LAU is set to "OFF", the lead angle setting function can be turned off even if TBM is set to "LV1" or "LV2".

The MC940,960CR shows that the lead angle setting function is OFF ("0" timing) by flashing an LED.

Function

## Data Transfer "MDL TRANS"

This function copies the model memory data of one T4GRS to another T4GRS. Connect the communication port of both T4GRS together with the optional DSC cord for T4PK. Use this function with the T4GRS power switch set to the display side.

**Note:** If the T4GRS battery voltage drops, the display switches to low battery display. Therefore, use this function when there is ample battery capacity remaining.

Note: Since the receiving side writes the new contents of the currently selected model memory, always check the model number before executing this function.

Data is not interchangeable with another type of transmitter.

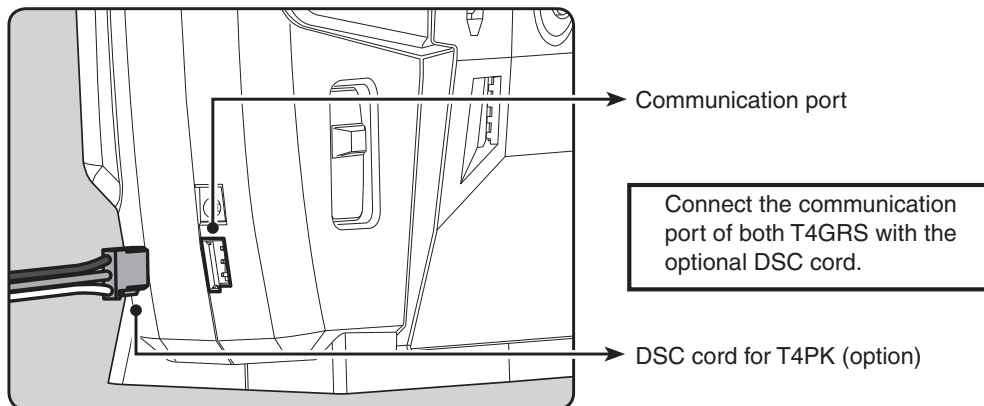

Display "MDL TRANS" screen by with the T4GRS power switch at the display setting using following method:

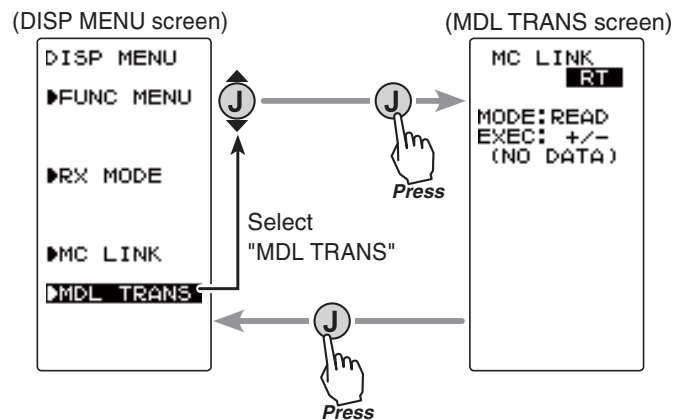

Function

### Using the Data Transfer function

(Preparation)

- Connect the communication port of both transmitters together with the optional DSC cord for T4PK.

- 1 Set the power switch of both transmitters to the display (DISP) setting.  
Use the (JOG) button and (+) button to display the "MDL-TRN" at both transmitter.

## 2 (Select the setting item )

"MODE" by the (JOG) button up or down operation, and select the transfer side and receive side by (+) or (-) button.

"TRAN":Data transfer side  
"RECV":Data receive side

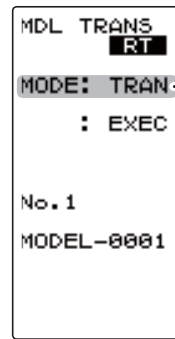

**Mode selection**  
"TRANSFER" "RECEIVE"  
**Setup item selection**  
- Select by (JOG) button up or down operation.  
**Mode change button**  
- Use the (+) and (-) buttons to make adjustments.

## 3 (Data transfer execution)

Select the setting item "EXEC" using (JOG) button up or down operation of both transmitter.

First, press the receive side "RECV" transmitter (+) and (-) buttons simultaneously. The message "RCV WAIT.." appears and count down begins.

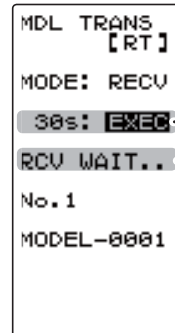

**Transfer execution button**  
- (+) and (-) buttons pressed simultaneously for about 1 second.  
30 seconds wait is displayed on the receive side screen.

Within 30 seconds, press the transfer side "TRANS" transmitter (+) and (-) buttons simultaneously. (If data transfer is not executed within 30 seconds, an error will be displayed at the receive side "RECV" transmitter.)

- "COMPLETE!" is displayed on the screen of the receive side "RECV" transmitter and data transfer is ended.

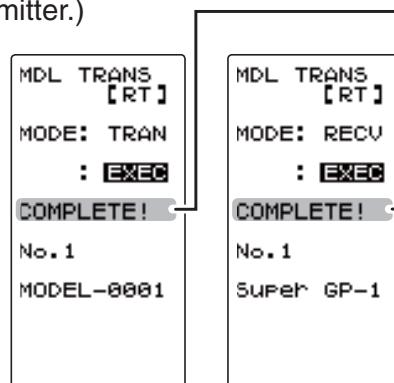

"COMPLETE!" is displayed.

-If "RCV ERROR!" is displayed on the screen of the receive side "RECEIVE" transmitter, data transfer was not performed normally. Check the connection and repeat steps 1→3. Since the transfer side "TRANS" transmitter only sends, "COMPLETE!" is displayed even when data transfer was not performed normally.

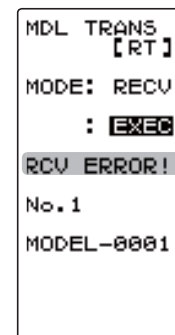

"RCV ERROR!" is displayed.

Data transfer can also be canceled before the end of transfer by operating the (JOG) button at a T4GRS that is waiting to receive data.

When completed, return to the DISP MENU screen by pressing the (JOG) button.

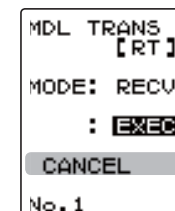

"CANCEL" is displayed.

# Timer Function "TIMER"

Use the timer by selecting one of the three timers UP TIMER, DOWN TIMER, and LAP TIMER.

Display "TIMER" screen by the following method:

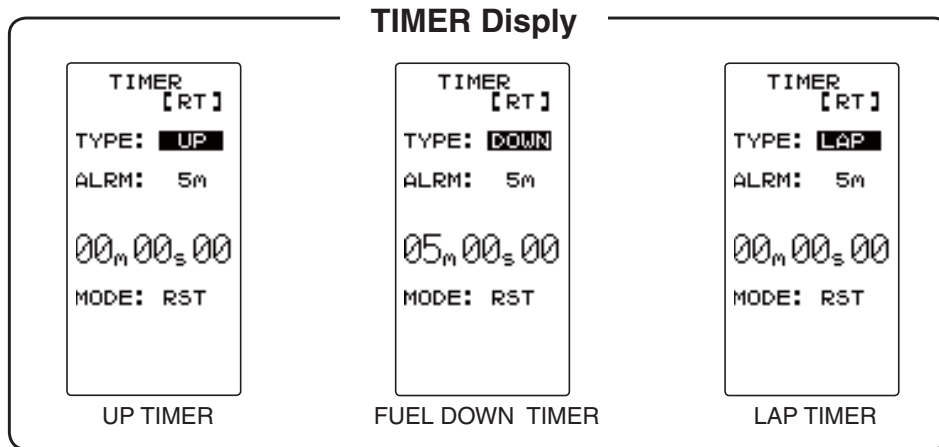
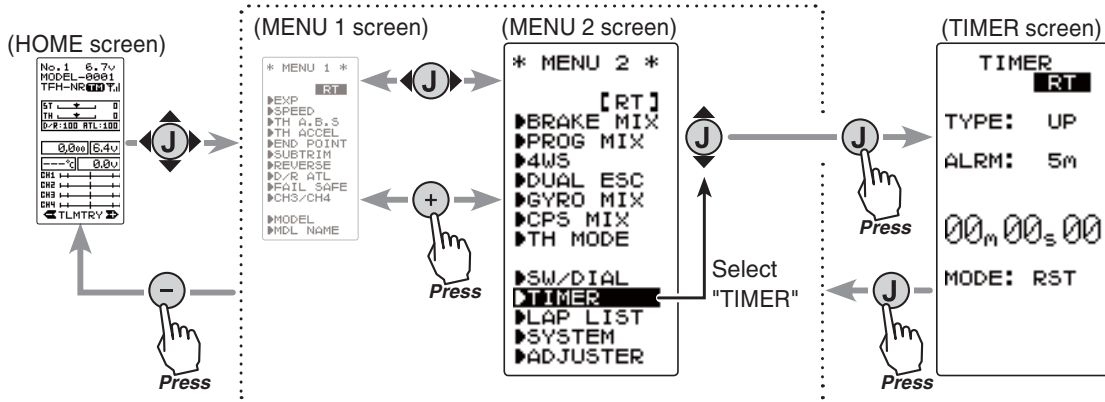

## UP TIMER function

### Up timer function

- This function can be used to count the time between start and stop, etc.
- The timer repeatedly starts and stops each time the switch is pressed and accumulates the time between each start and stop. When the count reaches 99 minutes 99 seconds, the count returns to 00 minutes 00 seconds and is repeated.
- The first start operation can be linked to the throttle stick.
- The passage of time is announced by sounding of a buzzer (beep) each minute after starting.

- Alarm :Beep sounds at the set time (minute).
- Prealarm :Alarm advance announcement sound. Beeping begins 5 seconds before the alarm.(beeps)

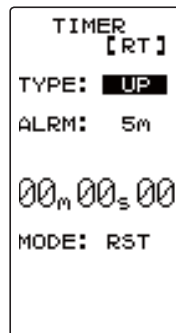

- After starting, the timer continues to count and can be stopped by switch even when the LCD switches to another screen.

## FUEL DOWN TIMER function

### Fuel down timer function

- This function is primarily used to check the refueling time of a gasoline car. (The remaining time is displayed.)
- Each time the switch is pressed, the timer is restarted and the set time is reset. The start time becomes the alarm set time. (When counted down to 00 minute 00 second, the down timer becomes an up timer.)
- The down timer can be initially started by throttle stick.
- The passing of time is indicated by sounding of a buzzer (beep) each minute after starting.

- Alarm :A beep sounds at the set time (minute).
- Prealarm :Alarm advance announcement sound. Beeping begins 5 seconds before the alarm.(beeps)

- After starting, the timer continues to count even if the LCD switches to another screen.

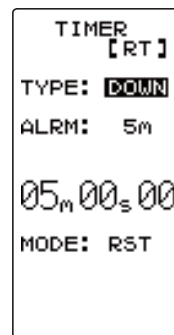

## LAP TIMER

### Lap timer function

- Each lap time can be memorized by switch operation. (100 laps)
- The race time can be set. Switch operation after the time set by alarm has elapsed automatically stops the timer. The passing of time is indicated by sounding of a buzzer (beep) each minute after starting.

- Alarm :Beep sounds at the set time.
- Prealarm :Alarm advance announcement sound. Sounding begins 5 seconds before the alarm. (beeps)

- The lap timer can be initially started by throttle stick.

### (LAP TIMER operation)

- The lap timer is started by switch or throttle stick.
  - Number of laps (LAP): After starting, the timer is counted up and the lap time blinks for 3 seconds each time the switch is pressed. To prevent erroneous counting, switch operation is not accepted during this period. When 1 lap exceeds 10 minutes, counting is repeated from 0.
  - Lap list: Up to 100 lap times are memorized beginning from lap list 1. After lap memory "No.100", operation returns to lap memory "No.1" and the lap memories are overwritten.
  - The lap time data memorized in the lap memories can be checked with the lap list screen. The entire lap list data is cleared the next time the lap timer is started.
  - TIME: For the first 3 seconds, the preceding lap time is displayed. After that the current lap time is displayed.

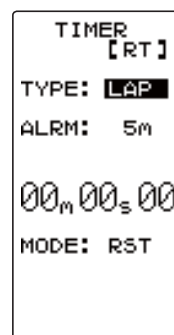

## Timer screen

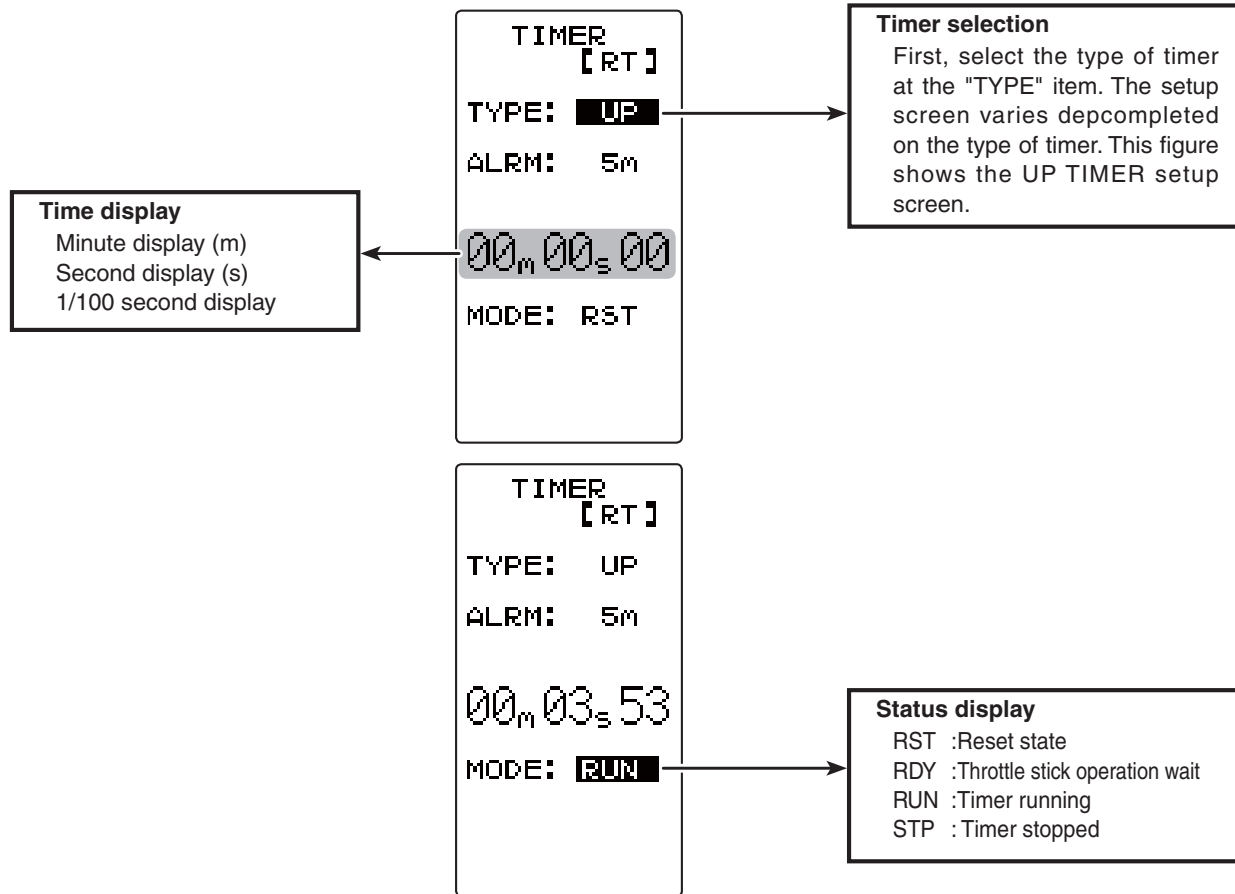

### Racing timer type selection

(Preparation)

Assign the "TIMER" switch using the function select switch .

#### 1 (Racing timer type selection)

Select the setting item "TYPE" using the (JOG) button. Use the (+) or (-) button and set the racing timer type.

#### Setup item selection

- Select by the (JOG) button.

Timer selection (TYPE)

UP : Up timer

DOWN : Down timer

LAP : Lap timer

#### Adjustment buttons

- Use the (+) and (-) buttons to make adjustments.

#### 2 When completed, return to the MENU2 screen by pressing the (JOG) button.

## Using the up timer

(Preparation)

Select the setting item "TYPE" using the (JOG) button.

Press the (+) or (-) button and select "UP".

### Adjustment buttons

- Use the (+) and (-) buttons to make adjustments.
- Press the (+) and (-) buttons simultaneously (approx. 1 sec) to return to the HOME screen.

### 1 (Alarm time setting)

Select the setting item "ALRM" using the (JOG) button and set the alarm time with the (+) or (-) button.

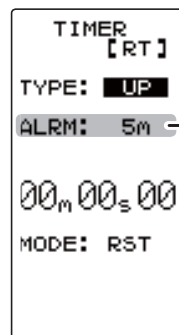

### Alarm time (ALRM)

OFF, 1 ~ 99 m  
Initial value: 5 m

### 2 (Timer start/stop operation)

Start the timer by pressing the switch ("TIMER") set by function select switch function.

Stop the timer with the same switch ("TIMER") as start.

- Linking start only to the throttle stick

Select the setting item "RST" using the (JOG) button and press the (+) and (-) buttons simultaneously for approximately 1 second. When the set beeps and the status display switches from "RST" to blinking "RDY", the system enters the stick operation ready state. When the stick is operated in the forward direction, the timer starts. (Status display "RUN")

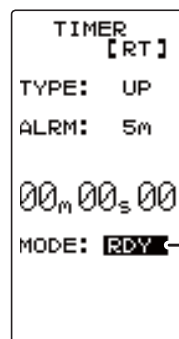

### Switches

Time start / stop

### Status display

RST :Reset state  
RDY :Throttle stick operation wait  
RUN :Timer running  
STP :Timer stopped

If the (JOG) button is pressed while the timer is operating, the LCD returns to MENU2 screen.

### 3 (Timer reset operation)

Select a status display ("RUN", "STP", or "RDY") direction the (JOG) button and press the (+) and (-) buttons simultaneously for approximately 1 second. A beep is generated and "RST" appears on the status display and the timer resets.

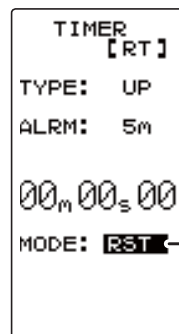

### Status display

RST :Reset state  
RDY :Throttle stick operation wait  
RUN :Timer running  
STP :Timer stopped

## Using the fuel down timer

(Preparation)

Select the setting item "TYPE" using the (JOG) button.

Press the (+) or (-) button and select "DOWN".

### Adjustment buttons

- Use the (+) and (-) buttons to make adjustments.
- Press the (+) and (-) buttons simultaneously (approx. 1 sec) to return to the HOME screen.

### 1 (Alarm time setting)

Select the setting item "ALRM" using the (JOG) button and set the alarm time with the (+) or (-) button.

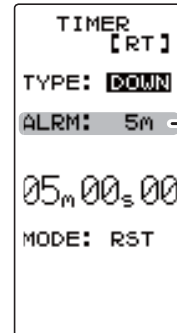

#### Alarm time (ALRM)

OFF, 1 ~ 99 m  
Initial value: 5 m

### 2 (Alarm start/restart operation)

When the switch ("TIMER") set by function select switch function is pressed, the timer starts. When the same switch ("TIMER") is pressed while the timer is operating, the timer is reset and simultaneously restarted. (Restart)

- Linking start only to the throttle stick

Select the setting item "RST" using the (JOG) button and press the (+) and (-) buttons simultaneously for about 1 second. When the set beeps and the status display switches from "RST" to blinking "RDY", the system enters the stick operation ready state.

When the stick is operated in the forward direction, the timer starts. (Status display "RUN")

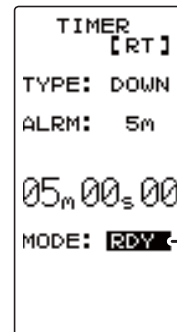

#### Switches

Timer start / restart

#### Status display

RST :Reset state  
RDY :Throttle stick operation wait  
RUN :Timer running  
STP :Timer stopped

If the (JOG) button is pressed while the timer is operating, the LCD returns to MENU2 screen.

### 3 (Timer reset operation)

Select a status display ("RUN") using the (JOG) button and press the (+) and (-) buttons simultaneously for approximately 1 second. A beeping sound is generated and "RST" appears on the status display and the timer resets.

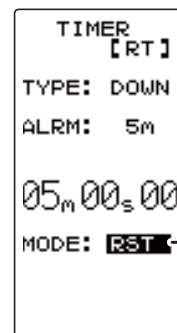

#### Status display

RST :Reset state  
RDY :Throttle stick operation wait  
RUN :Timer running  
STP :Timer stopped



## Using the Lap timer

(Preparation)

Select the setting item "TYPE" using the (JOG) button.

Press the (+) or (-) button and select "LAP".

### Adjustment buttons

- Use the (+) and (-) buttons to make adjustments.
- Press the (+) and (-) buttons simultaneously (approx. 1 sec) to return to the HOME screen.

### 1 (Alarm time setting)

Select the setting item "ALRM" using the (JOG) button and set the alarm time with the (+) and (-) buttons.

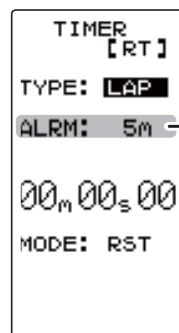

#### Alarm time (ALRM)

OFF, 1 ~ 99 m  
Initial value: 5 m

### 2 (Timer start/ lap count/ stop operation)

When the Timer switch (set in the Function select menu) is pressed, the timer starts. During operation, the same switch becomes the lap switch and when the set time elapses, the timer is stopped by the same switch (TIMER)

- Linking start only to the throttle stick

Select the setting item "RST" by the (JOG) button and press the (+) and (-) buttons simultaneously for about 1 second. When the set beeps and the status display switches from "RST" to blinking "RDY", the system enters the stick operation ready state. When the stick is operated in the forward direction, the timer starts. (Status display "RUN")



#### Switches

Timer start / Lap count

#### Status display

RST :Reset state  
RDY :Throttle stick operation wait  
RUN :Timer running  
GOAL: Timer stopped

When the switch (TIMER) is pressed after the time set by alarm has elapsed, the timer stops and the lap time and total time are memorized. The status display becomes "GOAL".

If the (JOG) button is pressed while the timer is operating, the LCD returns to MENU2 screen.

### 3 (Timer reset operation)

Select a status display ("GOAL") using the (JOG) button and press the (+) and (-) buttons simultaneously for approximately 1 second. A beeping sound is generated and "RST" appears on the status display and the timer resets.

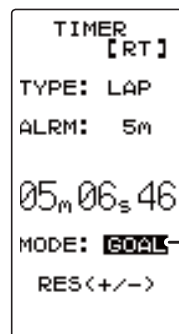

#### Status display

RST :Reset state  
RDY :Throttle stick operation wait  
RUN :Timer running  
GOAL: Timer stopped

- If the reset operation was performed before the "ALRM" set time had elapsed, the total time is not memorized.
- The lap memory data can be checked with the lap list screen.

# Lap List "LAP LIST"

The lap list is displayed when checking the lap memory data (lap times) memorized by lap timer operation.

- After the lap timer starts, the lap times are memorized sequentially each time the switch is operated.

- If the timer is stopped after the set ALRM time has elapsed, the final lap time is memorized and the total time after the last lap is automatically written.

- When the timer was stopped before the set ALRM time has elapsed, the total time is not memorized.

Display "LAP LIST" screen by the following method:

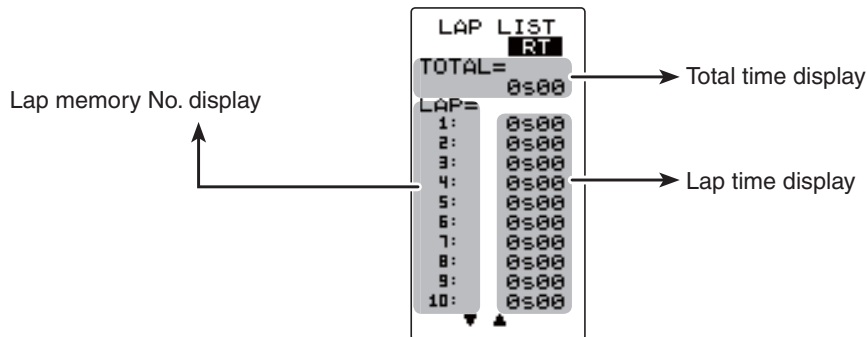
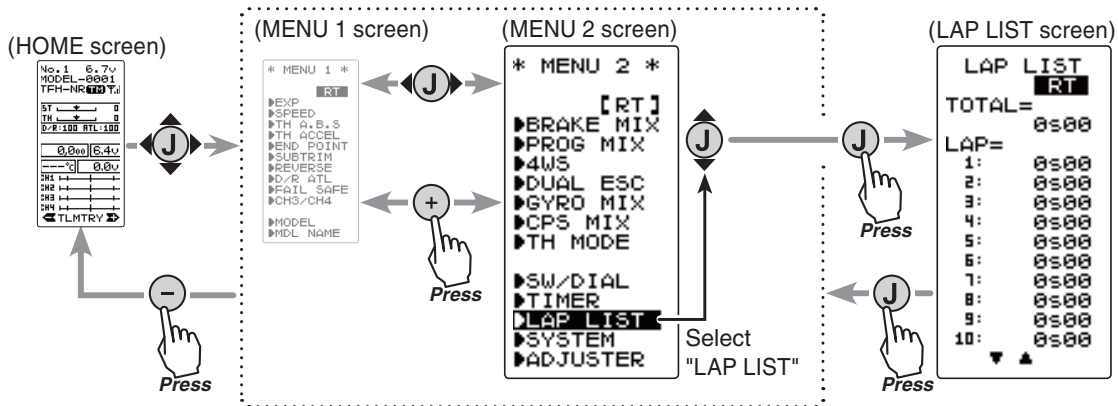

## Using the lap memory

### 1 (Lap memory check)

When the (JOG) button is pressed, the list is scrolled every 10 laps and each lap time can be checked.

### 2 (Lap memory total data reset)

Press the (+) and (-) buttons simultaneously for approximately 1 second. A beeping sound is generated and all the data is reset.

#### Reset button

- Reset by pressing the (+) and (-) buttons simultaneously for about 1 second.

### 3 When completed, return to the MENU2 screen by pressing the (JOG) button.

# System Functions "SYSTEM"

The graphic liquid crystal screen display mode, buzzer sound and menu character mode, etc. can be set.

- "CONTRA"---Liquid crystal screen contrast adjustment (20 steps)
- "BK-LHT"---Liquid crystal screen backlighting display mode setup (OFF, ON at button operation, normally ON)
- "LHT-TM"---Setting of ON time (1~30 secs) when [ON at button operation] was selected above.
- "LHT-PW"---Liquid crystal screen backlighting brightness adjustment (30 steps)
- "BATT"---Battery type setting (LiFe2/NiMH5/DRY4)  
The T4GRS can use an optional rechargeable battery. However, the battery alarm setting is different from that of the dry cell battery (alkaline battery recommended). Therefore, always set the battery type to match the power source used.  
If used with the incorrect setting, the normal low battery alarm function will not work and the system may stop before a battery alarm is generated. The usage time may also become extremely short.
- "BUZZER"---Buzzer sound tone adjustment (OFF, 100 steps)
- "OPE-TM"---Alarm Setting if Tx is left switched ON (OFF, 10 m)
- "MENU"---Item which displays the basic menu screen in katakana characters for Japanese use.
- "TH-STK"---This is used, when the neutral adjuster of throttle stick is changed, or when it is changed into ratchet.(5:5, 7:3, F10)
- "DISP"---HOME screen display mode setting (Telemetry data, Timer, Users name)

Display "SYSTEM" screen by the following method:

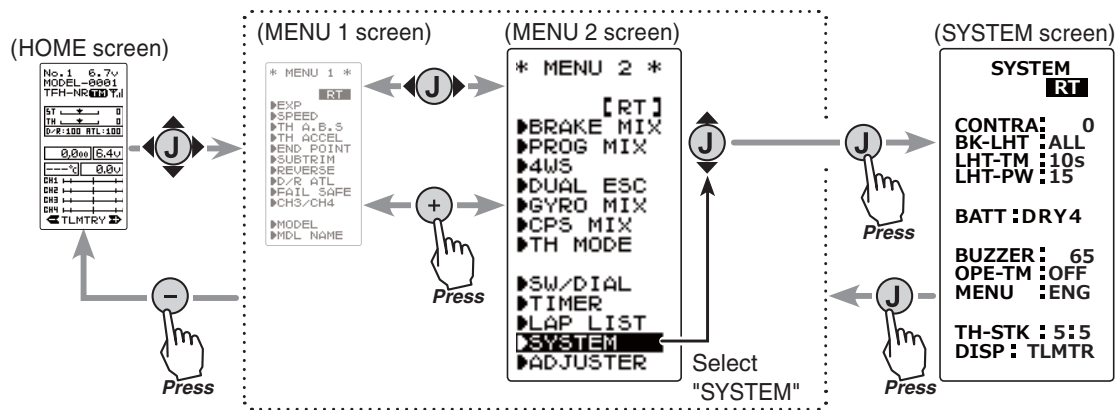

## System function setup

### 1 (Setting of each item)

#### (Adjusting the liquid crystal contrast)

Select the setting item "CONTRA" using the (JOG) button, and use the (+) and (-) buttons to adjust the screen contrast.

- Adjust to an easy-to-see contrast.

When completed, return to the MENU2 screen by pressing the (JOG) button.

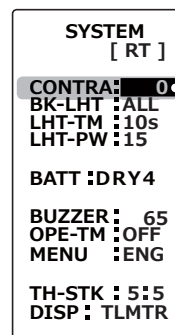

#### Adjustment buttons

- Use the (+) and (-) buttons to make adjustments.
- Press the (+) and (-) buttons simultaneously (approx. 1 sec) to return to the initial value.

#### Contrast (CONTRA)

-10~0~+10  
Initial value: 0

Function

## System function setup (Setting the liquid crystal backlighting mode)

Select the setting item "BK-LHT" using the (JOG) button, and select the mode by pressing the (+) or (-) button.

"KEY" :Fixed time backlighting ON after button operated.  
 "ALL" :Backlighting always ON  
 "OFF" :Backlighting OFF

When completed, return to the MENU2 screen by pressing the (JOG) button.

## (Setting liquid crystal backlighting time)

Select the setting item "LHT-TM" using the (JOG) button, and use the (+) and (-) buttons to set the ON time.

- When "KEY" is set at the preceding item, this ON time becomes effective.

When completed, return to the MENU2 screen by pressing the (JOG) button.

## (Setting liquid crystal backlighting brightness)

Select the setting item "LHT-PW" using the (JOG) button, and use the (+) and (-) buttons to set the ON time.

-If too set too bright, the battery will quickly be flattened.

When completed, return to the MENU2 screen by pressing the (JOG) button.

## (Setting the battery type)

Select the setting item "BATT" using the (JOG) button, and select the mode by pressing the (+) or (-) button. When changing the battery type, press the (JOG) button after thoroughly checking that the correct battery type has been entered. An electronic beeping sound is generated and the setting is changed.

**Note:** If the battery type is changed to the wrong setting, the low battery alarm will be generated immediately after the change and operation will become impossible.

When the low battery alarm was generated, turn off the power and replace the battery with a fully charged battery or a new dry cell battery and then reset the battery type.

```

SYSTEM
[ RT ]
CONTRA: 0
BK-LHT: ALL
LHT-TM: 10s
LHT-PW: 15
BATT: DRY4
BUZZER: 65
OPE-TM: OFF
MENU: ENG
TH-STK: 5:5
DISP: TLMTR
  
```

→ Backlight mode (BK-LHT)  
KEY, ALL, OFF

```

SYSTEM
[ RT ]
CONTRA: 0
BK-LHT: ALL
LHT-TM: 10s
LHT-PW: 15
BATT: DRY4
BUZZER: 65
OPE-TM: OFF
MENU: ENG
TH-STK: 5:5
DISP: TLMTR
  
```

→ Backlighting time (LHT-TM)  
1~30  
Initial value: 10

```

SYSTEM
[ RT ]
CONTRA: 0
BK-LHT: ALL
LHT-TM: 10s
LHT-PW: 15
BATT: DRY4
BUZZER: 65
OPE-TM: OFF
MENU: ENG
TH-STK: 5:5
DISP: TLMTR
  
```

→ Backlighting brightness (LHT-PW)  
1~30  
Initial value: 15

```

SYSTEM
[ RT ]
CONTRA: 0
BK-LHT: ALL
LHT-TM: 10s
LHT-PW: 15
BATT: DRY4
BUZZER: 65
OPE-TM: OFF
MENU: ENG
TH-STK: 5:5
DISP: TLMTR
  
```

→ Battery Type (BATT)  
LiFe2, DRY4, NiMH5

**Note:** If used with the incorrect setting, a normal low battery alarm will not be generated and the system may stop before the battery alarm is generated. The usage time may also become extremely short.

- "LiFe2" :Futaba LiFe type battery (FT2F1700BV2 / 2100BV2)
- "NiMH5" :Futaba NiMH type battery (HT5F1800B)
- "DRY4" :Dry cell battery (alkaline battery recommended) 4 batteries

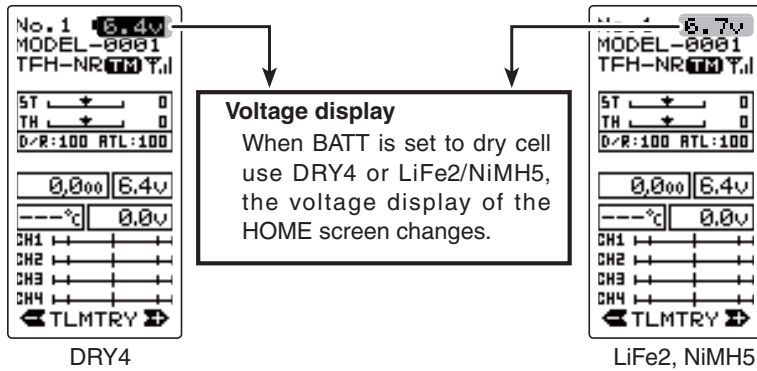

When completed, return to the menu screen by pressing the (JOG) button.

### (Adjusting the buzzer tone)

Select the setting item "BUZZER" using the (JOG) button, and use the (+) and (-) buttons to adjust the tone.

- Decide by referring to the tone at adjustment.

When completed, return to the menu screen by pressing the (JOG) button.

```

SYSTEM
[ RT ]
CONTRA: 0
BK-LHT : ALL
LHT-TM : 10s
LHT-PW : 15
BATT : DRY4
BUZZER : 65
OPE-TM : OFF
MENU : ENG
TH-STK : 5:5
DISP : TLMTR
  
```

**Buzzer tone (BUZZER)**  
OFF, 1~100  
Initial value: 85

### (Changing the Alarm Setting if Tx is left switched ON)

Select the setting item "OPE-TM" using the (JOG) button, and use the (+) and (-) buttons to select the alarm setting if Tx is left switched ON mode.

- "10m" :If an operation is not performed within 10 minutes while the power is on, an audible alarm sounds.
- "OFF" :Alarm setting if Tx is left switched ON is OFF

```

SYSTEM
[ RT ]
CONTRA: 0
BK-LHT : ALL
LHT-TM : 10s
LHT-PW : 15
BATT : DRY4
BUZZER : 65
OPE-TM : OFF
MENU : ENG
TH-STK : 5:5
DISP : TLMTR
  
```

**The power off forgotten alarm (OPE-TM)**  
10m, OFF

When completed, return to the menu screen by pressing the (JOG) button.

Function

### (Changing the menu character display)

Select the setting item "MENU" using the (JOG) button, and set the basic menu character display with the (+) or (-) button.

"ENG" : Basic menu displayed in Alphabetic character.  
 "カナ" : Basic menu displayed in katakana character.

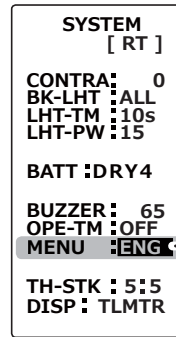

Menu character (MENU)  
 ENG, カナ

When completed, return to the menu screen by pressing the (JOG) button.

### (When the neutral adjuster of throttle stick is changed )

Select the setting item "TH-STK" using the (JOG) button, and set the neutral adjuster position mode with the (+) or (-) button.

"5:5" :Normal  
 "7:3" :Forward stick travel is increased  
 "F10" :When ratchet is being used (for GP boat)

Press the (JOG) button after thoroughly checking whether or not the mistake was made again. An electronic beeping sound is generated and the setting is changed.

When completed, return to the menu screen by pressing the (JOG) button.

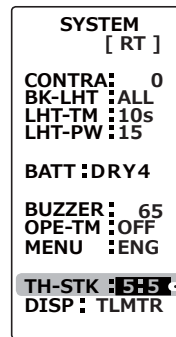

Throttle stick (TH-STK)  
 5:5, 7:3, F10 (forward only)

When changed into **F10** (forward only), brake set-up cannot be activated. The display of "**NO BRAKE**" or " — — — " comes out on each screen, and a setup is impossible.

### (Changing the HOME screen display mode)

Select the setting item "DISP" using the (JOG) button, and set the HOME screen display mode with the (+) or (-) button.

"TLMTR" :Telemetry data is displayed  
 "TIMER" :Timer is displayed  
 "USER" :User name is displayed

Only the T-FHSS system can display telemetry data. Nothing is displayed with an S-FHSS/FHSS system.

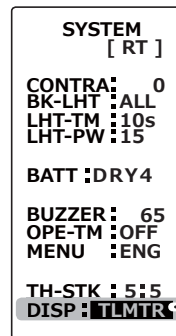

HOME screen mode (DISP)  
 TLMTR, TIMER, USER

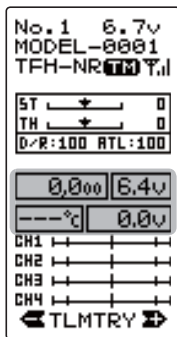

TLMTR

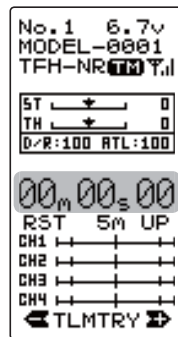

TIMER



USER

# Adjuster "ADJUSTER"

Steering stick and throttle stick neutral position and servo operating angle correction can be applied. This is used when a mechanical offset has occurred for some reason.

\*However, when correction is made, the set value of all the setting functions must be rechecked.

Display the adjuster screen from the system menu.

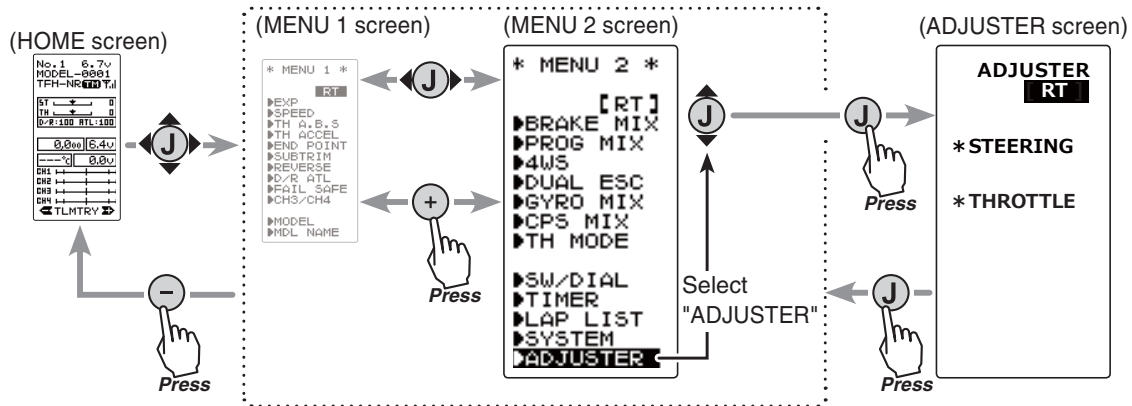

## Steering adjustment

(Preparation)

On the ADJUSTER screen, select the setting item "Steering" using the (JOG) button, and pressing the (JOG) button.

### 1 (Steering neutral adjustment)

In the neutral setup screen (fig-1) state, pull the stick back slightly then allow to return to neutral and press the (JOG) button whilst ensuring the stick is not touched.

### 2 (Steering throw adjustment)

In the throw setup screen state (fig-2), lightly turn the stick fully to the left or right and when button mark (fig-3) is displayed, pressing the (JOG) button.

Internal check is performed automatically. When each adjustment point is within a fixed range, correction is performed and "COMPLETE" (fig-4) is displayed.

If an adjustment point is not within a fixed range, correction is not performed and the correction data is not updated.

When button mark is not displayed even though correction was performed again, please contact a Futaba Radio Control Customer Center.

### 3 When completed, return to the MENU2 screen by pressing the (JOG) button.

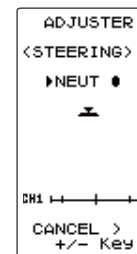

fig-1

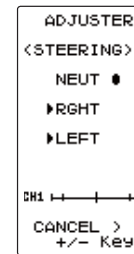

fig-2

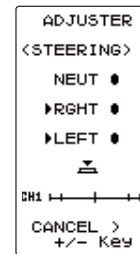

fig-3

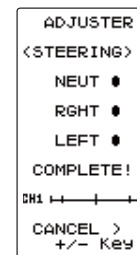

fig-4

Function

## Throttle adjustment

(Preparation)

On the ADJUSTER screen, select the setting item "THROTTLE" using the (JOG) button, and press the (JOG) button.

Throttle adjustment will not be made if it has been converted to ratchet operation. It is necessary to return to a self neutral.

### 1 (Throttle 5:5 neutral adjustment )

Neutral adjuster is set to 5:5 by the Neutral Adjuster switch. In the 5:5 neutral setup screen (fig-1) state, pull the stick back slightly then allow to return to neutral and press the (JOG) button whilst ensuring the stick is not touched.

### 2 (Throttle 7:3 neutral adjustment )

Neutral adjuster is set to 7:3 by the Neutral Adjuster switch. In the 7:3 neutral setup screen (fig-2) state, pull the stick back slightly then allow to return to neutral and press the (JOG) button whilst ensuring the stick is not touched.

Note that both the 5:5 and 7:3 neutral adjustment procedures have to be completed as part of the set-up process. Once complete the required option should be selected.

### 3 (Throttle throw adjustment)

In the throw setup screen state (fig-3), gently move the stick fully to the brake side and the forward side and when button mark (fig-4) is displayed, pressing the (JOG) button.

Internal check is performed automatically. When each adjustment point is within a fixed range, correction is performed and "COMPLETE!" (fig-5) is displayed.

If an adjustment point is not within a fixed range, correction is not performed and the correction data is not updated.

When button mark is not displayed even though correction was performed again, please contact a Futaba Radio Control Customer Center.

4 When completed, return to the ADJUSTER screen by pressing the (JOG) button.

5 Next, move the cursor to [RT] using the (JOG) button, and press the (JOG) button.

(Throttle stick)

### Neutral Adjuster

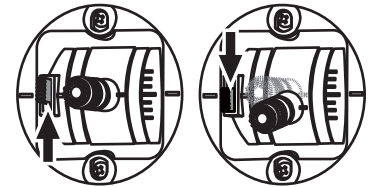

5 : 5

7 : 3

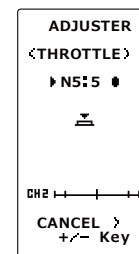

fig-1

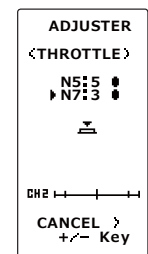

fig-2

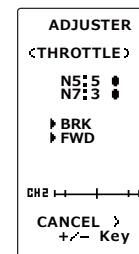

fig-3

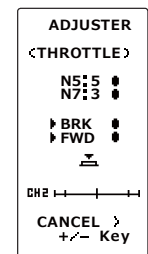

fig-4

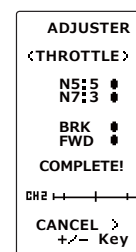

fig-5



# Telemetry "TELEMETRY"

With the telemetry system, the running status can be displayed at the transmitter and also recorded as a data log by mounting various sensor units to the chassis.

The telemetry related screens are only displayed when the T4GRS power switch is in the PWR ON position. When the power switch is in the DISP position, the telemetry related screens are not displayed.

The T4GRS displays four kinds of information on the HOME screen; receiver power source (battery) voltage, external power supply (drive battery) voltage, speed, and temperature.

- \*The telemetry function is compatible with only the T-FHSS system.
- \*The telemetry function requires a corresponding receiver (R304SB,R304SB-E).
- \*Only T4GRS with R304SB(-E) ID registered have a telemetry display.
- \*Multiple sensors of the same type cannot be used.

The sensor data can be checked at the transmitter by connecting the telemetry sensor sold separately to the S.BUS2 connector of the R304SB(-E) receiver.

The figure is an example of connection of a telemetry sensor. The data of up to the following 3 types of sensors and the receiver power supply voltage can be transmitted by using the 3-way extension cord or double extension cord sold separately.

The receiver power supply can also be connected to the S-BUS2 connector or each of CH1-4. A receiver power supply voltage sensor is unnecessary.

\*The S-BUS2 system exerts control by connecting multiple gyros, servos and other devices corresponding to one S-BUS2 connector. Each device is separately controlled by setting the channel No. or slot No. individually for each device. A slot No. is also set for telemetry sensors. With the T4GRS system, each slot No. of a telemetry sensor must be set to its initial value. Since the slot No. can be changed for other aircraft type transmitters (T18MZ, etc.), sensors with changed slot No. will not operate if not returned to their initial slot No. When using a sensor that is used with transmitters other than a T4GRS, whether or not the slot No. is set to the initial value given in the sensor instruction manual must be checked at the changed transmitter (T18MZ, etc.). With the T4GRS, the set slot No. cannot be checked or changed. So, essentially, if a sensor has been used in an 18MZ, and you want to use the same sensor with your T4GRS, you must first change the slot number through the 18MZ or it will not work in your T4GRS.

(HOME screen)

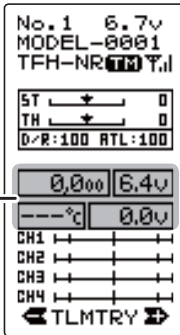

Telemetry info

## Connection diagram

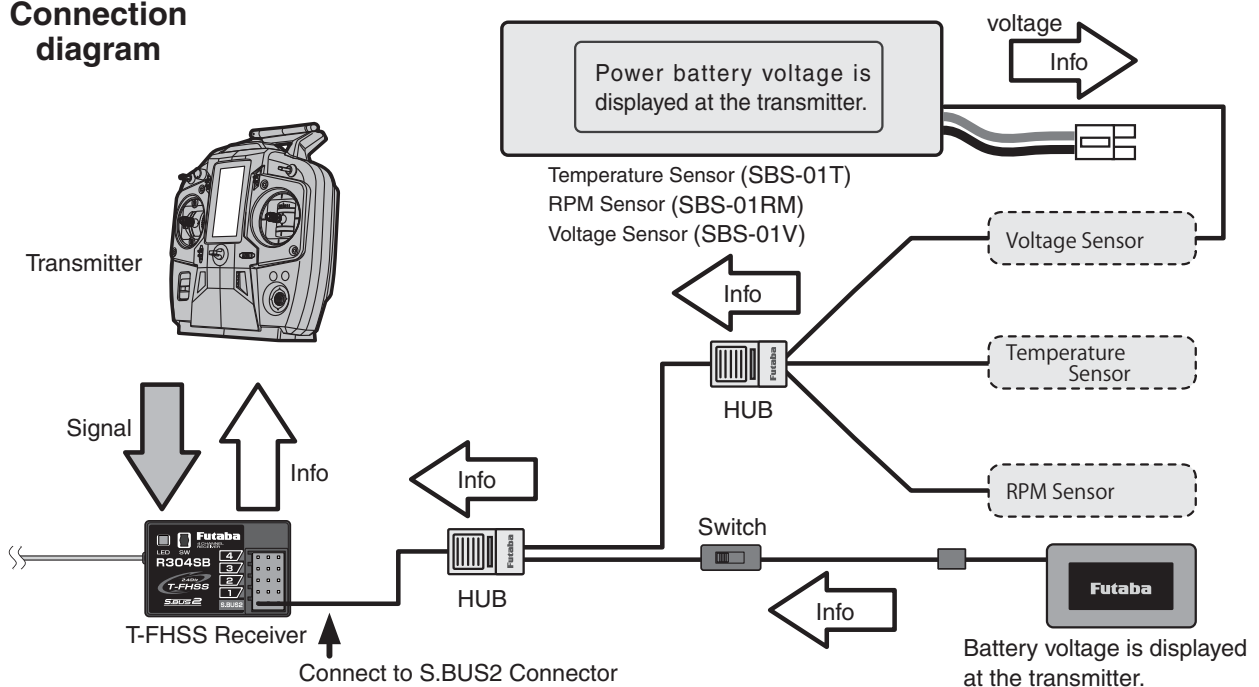

Function

# Telemetry/Log Screen Map

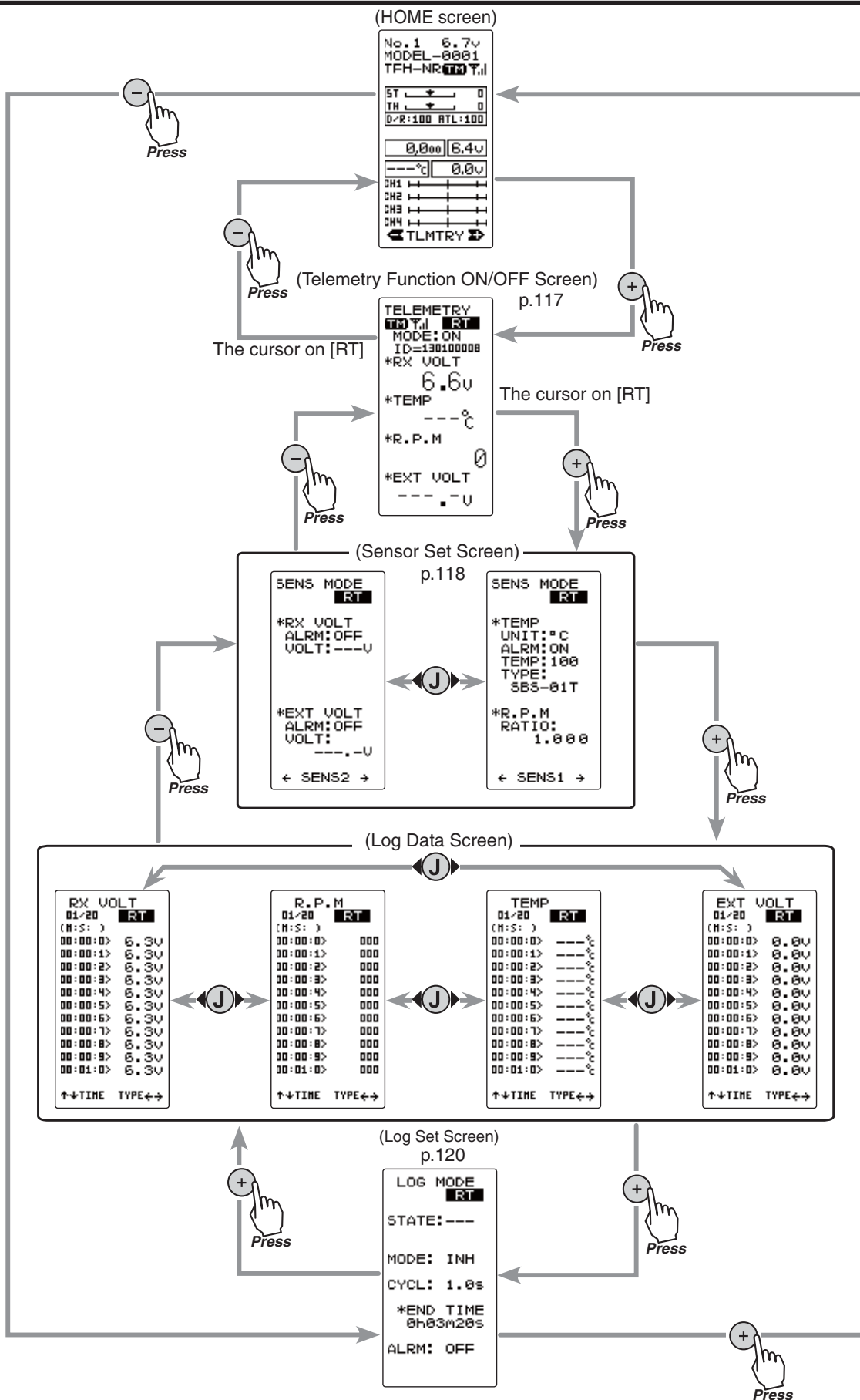

Function

# Telemetry Function ON/OFF

The telemetry data can be viewed at the HOME screen and telemetry ON/OFF screen. The telemetry function can also be turned on and off at the telemetry ON/OFF screen. The telemetry ON/OFF and communication status can be checked at the HOME screen.

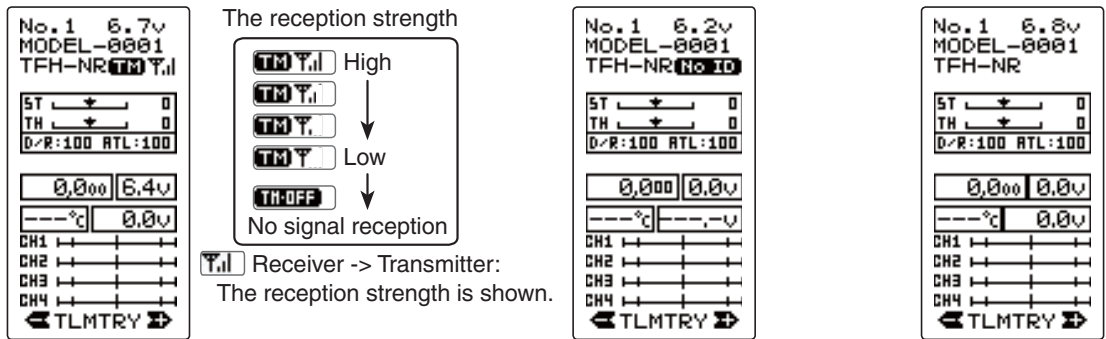

- Telemetry function :ON
- Receiver ID setting complete.
- Data receiving sensitivity display.
- **TM-OFF** shows that data cannot be received because it is outside the data receiving range or because of the effects of an obstruction or the receiver power is OFF after receiver ID check.
- Telemetry function :ON
- Receiver ID before setting or ID mismatch.
- When the receiver ID is set, before ID check in the receiver power OFF state.
- Telemetry function :OFF

Refer to the map on page 116 for the telemetry ON/OFF (telemetry) screen display.

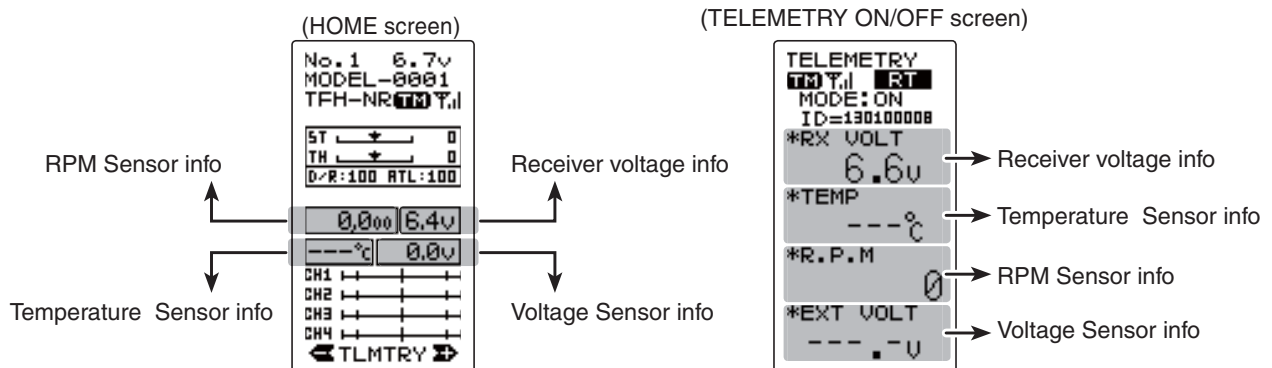

## Telemetry function ON/OFF

(Preparation)

- On the HOME screen, open the TELEMETRY ON/OFF screen by pressing the (+) button.



Telemetry turned ON, LED of the jog key will blink twice.

**1** Select the setting item "MODE" using the (JOG) button up or down operation. Set the function by pressing the (+) or (-) button.

"OFF" : Function OFF  
"ON" : Function ON

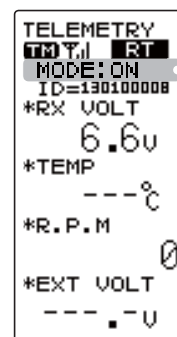

Function ON/OFF (MODE)

INH, ACT

Select button

- Select with the (+) or (-) buttons.

**2** When completed, move the cursor to [RT] by the (JOG) button, and return to the HOME screen by pressing the (JOG) button.

# Telemetry Sensor Setting

An audible alarm can be generated by the T4GRS from the data from a telemetry sensor. This setting sets alarm ON/OFF and the alarm conditions.

Refer to the map on page 116 for the sensor setting (SENS MODE) screen display.

There are receiver power source (battery) voltage and external power source (drive battery) voltage settings on page 1 of the sensor setting screen and temperature and speed settings on page 2. Pages 1 and 2 are switched by (JOG) button left or right operation.

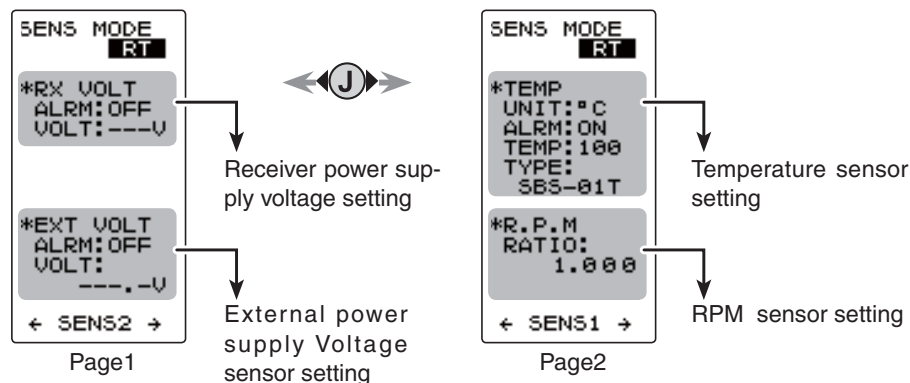

## Setting method

(Setting of each item)

### Setting the receiver power supply voltage alarm

Display page 1 using (JOG) button left or right operation.

Select "ALRM" of the "\*RX VOLT" setting items using (JOG) button up or down operation, and set alarm ON/OFF with the (+) button or (-) button.

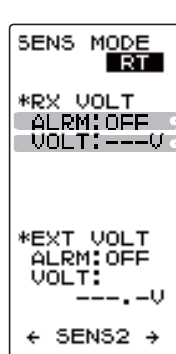

#### Alarm ON/OFF

ON, OFF  
- Select with the (+) or (-) buttons.

#### Voltage alarm

3.8V~8.0V  
Initial value: 5V

#### Adjust button

- Adjust with the (+) and (-) buttons.  
- Return to the initial value "0" by pressing the (+) and (-) buttons simultaneously for about 1 second.

"OFF" : Alarm OFF

"ON" : Alarm ON by a voltage drop below the specified voltage

Select "VOLT" of the "\*RX VOLT" setting items using (JOG) button up or down operation, and set the voltage at which the alarm begins to sound with the (+) button or (-) button. The number of digits can be shifted using (JOG) button left or right operation.

When completed, move the cursor to [RT] using the (JOG) button, and return to the HOME screen by pressing the (JOG) button twice.

### Setting external power supply voltage alarm

Display page 1 using (JOG) button left or right operation.

Select "ALRM" of the "EXT VOLT" setting items using (JOG) button up or down operation, and set alarm ON/OFF with the (+) button or (-) button.

"OFF" : Alarm OFF

"ON" : Alarm ON by a voltage drop below the specified voltage

Select "VOLT" of the "\*EXT VOLT" setting items using (JOG) button up or down operation, and set the voltage at which the alarm begins to sound with the (+) button or (-) button. The number of digits can be shifted using (JOG) button left or right operation.

When completed, move the cursor to [RT] using the (JOG) button, and return to the HOME screen by pressing the (JOG) button twice.

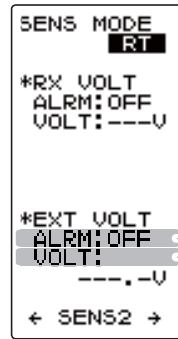

#### Alarm ON/OFF

ON, OFF

- Select with the (+) or (-) buttons.

#### Voltage alarm

0.0V~90.0V

Initial value: 5V

#### Adjust button

- Adjust with the (+) and (-) buttons.

- Return to the initial value "0" by pressing the (+) and (-) buttons simultaneously for about 1 second.

### Setting the temperature alarm

Display page 2 using (JOG) button left or right operation.

Select "UNIT" of the "\*TEMP" setting items using (JOG) button up or down operation, and select Celsius or Fahrenheit temperature display with the (+) button or (-) button.

"°C" : Celsius display

"°F" : Fahrenheit

Select "ALRM" of the "\*TEMP" setting items using (JOG) button up or down operation, and set alarm ON/OFF with the (+) button or (-) button.

"OFF" : Alarm OFF

"ON" : Alarm ON at the specified temperature

Select "TEMP" of the "\*TEMP" setting items using (JOG) button up or down operation, and set the temperature at which the alarm begins to sound with the (+) button or (-) button. Select "TYPE" of the "\*TEMP" setting items using (JOG) button up or down operation, and set the type of sensor with the (+) button or (-) button

"SBS-01T" : Option sensor

"Temp 125" : Option sensor for Europ

When completed, move the cursor to [RT] by the (JOG) button, and return to the HOME screen by pressing the (JOG) button twice.

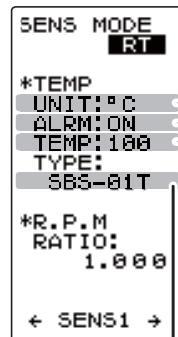

#### Display type

°C, °F

- Select with the (+) or (-) buttons.

#### Alarm ON/OFF

ON, OFF

- Select with the (+) or (-) buttons.

#### Temperature alarm

-20~200°C/ -4~392°F

Initial value: 200°C/ 212°F

#### Adjust button

- Adjust with the (+) and (-) buttons.

- Return to the initial value "0" by pressing the (+) and (-) buttons simultaneously for about 1 second.

#### Sensor type

SBS-01T, Temp 125

#### Select button

- Select with the (+) or (-) buttons.

Function

### Setting the gear ratio

Display page 2 using (JOG) button left or right operation. Select "RATIO" of the "R.P.M" setting items using (JOG) button up or down operation, and set the location the sensor is to actually measure and the gear ratio of the motor and engine with the (+) button or (-) button. There is no alarm function.

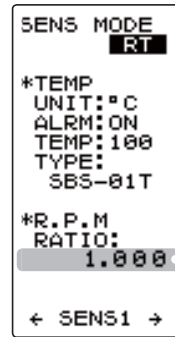

#### Gear ratio (moderating ratio)

0.001~64  
Initial value: 1

#### Adjust button

- Adjust with the (+) and (-) buttons.
- Return to the initial value "0" by pressing the (+) and (-) buttons simultaneously for about 1 second.

When completed, move the cursor to [RT] using the (JOG) button, and return to the HOME screen by pressing the (JOG) button twice.

## Log Setting Start/Stop

The data from a telemetry sensor can be saved to the T4GRS as a data log. Since the data is sequentially updated, when data logging is performed, the old data is erased. Only 1 data is saved.

The interval at which the data is acquired can be selected from a minimum 0.1 second to a maximum 60 seconds. Because the maximum count is 200, if the count is made 200 counts at 0.1 second intervals, 20 seconds worth of data is acquired, and if the count is made 200 counts at 60 second intervals, 3 hours 20 minutes worth of data is acquired.

Data logging is started and stopped by setting SW1 set by SW/Dial function to "LOGGER" and by switch (SW1). If the switch (SW1) is not set, data logging is started by throttle stick from the log setting screen.

Data logging can also be started by throttle stick from this screen and stopped by switch (SW1) set by SW/dial function.

Refer to the map on page 116 for the log setting (LOG MODE) screen display.

### Log setting method

(Preparation)

When using a switch (SW1) to start and stop data logging, set SW1 to "LOGGER" by SW/dial function.

- On the HOME screen, open the LOG MODE screen by pressing the (-) button.

#### 1 (Log function ON/OFF)

Move the cursor to the "MODE" setting item using (JOG) button up or down operation, and turn on the log function by setting "MODE" to "ACT" by pressing the (+) button or (-) button.

If "MODE" is not set to "ACT", the log function will not be performed even if the switch etc, is operated.

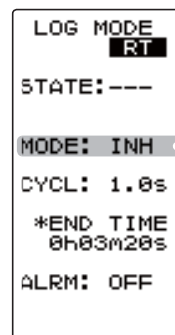

#### Function ON/OFF (MODE)

- INH, ACT
- Select with the (+) or (-) buttons.

"INH" : Function OFF  
"ACT" : Function ON

## 2 (Recording cycle setting)

Select the "CYCL" setting item using (JOG) button up or down operation, and set the data acquisition interval from a minimum 0.1 second to a maximum 60 seconds with the (+) button or (-) button.

The maximum recordable time set by CYCL is displayed at END TIME shown below.

```
LOG MODE
  RT
STATE: ---
MODE: INH
CYCL: 1.0s
*END TIME
  0h03m20s
ALRM: OFF
```

### Log recording cycle

0.1~60s(sec)  
0.1~10s(sec)0.1s step  
10s~60s(sec)1s step  
Initial value: 1.0sec

### Adjust button

- Adjust with the (+) and (-) buttons.
- Return to the initial value "0" by pressing the (+) and (-) buttons simultaneously for about 1 second.

## 3 (Count alarm ON/OFF)

Select the "ALRM" setting item using (JOG) button up or down operation. To sound an electronic beep at each log count, set "ALRM" to ON with the (+) button or (-) button.

"OFF" : Alarm OFF

"ON" : Alarm ON at each log count

```
LOG MODE
  RT
STATE: ---
MODE: INH
CYCL: 1.0s
*END TIME
  0h03m20s
ALRM: OFF
```

### Log recording time

20s (seconds)~3h 20m (3 hours 20 minutes)  
The maximum recordable time set by CYCL is displayed automatically.

### Alarm ON/OFF

- ON, OFF
- Select with the (+) or (-) buttons.

When completed, move the cursor to [RT] using the (JOG) button, and return to the HOME screen by pressing the (JOG) button twice.

## Log function start/stop operation

### 1 (Log start operation)

#### -Start by switch (SW1)

When the switch (SW1) set by SW/dial function is pressed, data logging starts.

#### -Starting by throttle stick

Display the log setting (LOG MODE) screen and select the "STATE" setting item using (JOG) button up or down operation, and press the (JOG) button for approximately 1 second.

```
LOG MODE
  [RT]
STATE: STP
  ( ← → RDY )
MODE: ACT
CYCL: 1.0s
*END TIME
  0h03m20s
ALRM: OFF
```

### Status display

RDY : Throttle stick operation wait  
STA : Logger running  
STP : Logger stopped

An electronic beeping sound is generated and the "STATE" display switches from "RST" to blinking "RDY", and the logger enters the stick operation wait state. When the stick is operated in the forward direction, data logging begins. (STATE display "STA") When the end time arrives, an electronic beep sounds and data logging stops. To return to the HOME screen during data logging, move the cursor to [RT] using (JOG) button up or down operation, and press the (JOG) button or (+) button.

### 2 (Log forced end)

To abort logging, press the switch (SW1), in the same way as starting, or display the log setting (LOG MODE) screen and select the "STATE" setting item using (JOG) button up or down operation and press the (JOG) button for approximately 1 second. An electronic beeping sound is generated and logging is stopped.

# Log Data List

The log data list can be called up when checking the log data memorized by logging operation .

The maximum log data is up to 200 counts.

Refer to the map on page 116 for the log list screen.

## Example: Receiver power supply voltage log list screen.

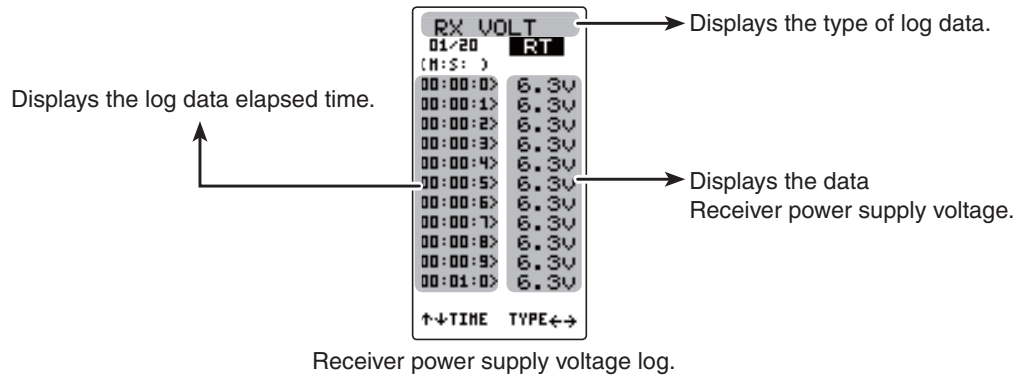

Refer to the below map for the display method of each log list screen.

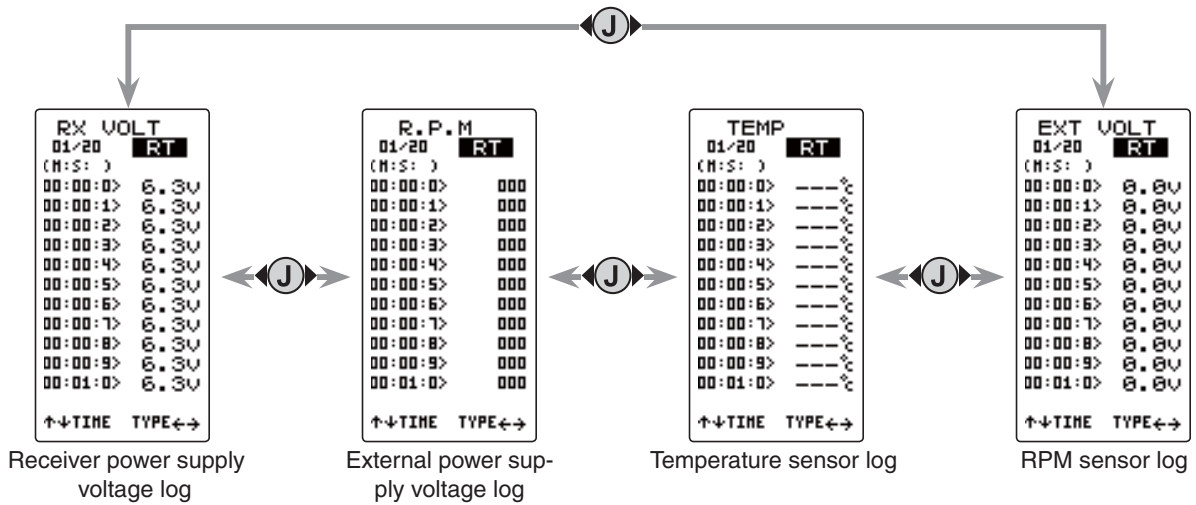

Function

### Log list check method

- 1 (Log memory check)  
Each time the (JOG) button is operated up or down the list is scrolled 10 counts and each log data can be checked up to 200 counts.
- 2 When completed, return to the HOME screen by pressing the (JOG) button.



## Ratings

\*Specifications and ratings are subject to change without prior notice.

**Communication method:** One-way operation system  
**Maximum operating range:** 100m (Optimum condition)  
**For safety:** F/S, B-F/S, ID

### Transmitter T4GRS-2.4G

(T-FHSS/S-FHSS/FHSS system, 2 stick type, 4 channels)

**Transmitting frequency:**

2.4GHz band

**Power requirement:**

AA Dry cell batteries x 4 (6V)

**Current drain:**

150mA or less

**Transmission antenna:**

1/2λ di-pole

### Receiver R304SB: (T-FHSS system, 4 channels)

**Power requirement:**

4.8V~7.4V battery / 3.5 ~ 8.4V useable  
 (Dry cell battery cannot be used.)

**Receiving frequency:**

2.4GHz band

**System:**

T-FHSS system (auto detection)

**Size:**

1.38x0.91x0.33" (35.1x23.2x8.5mm)(excluding a projection part)

**Weight:** 0.23oz. (6.6g)

## Caution

- ❗ When using the T4GRS in the T-FHSS (HIGH) and S-FHSS (HIGH) mode, always use it under the following conditions:

**Servos** :Futaba digital servo (including BLS Series brushless servos)  
**Receiver's battery** :Matched to the ratings of the receiver and connected digital servo (dry cell battery cannot be used).  
**Transmitter mode** :RX MODE

Under other conditions, the set will not operate, or the specified performance will not be displayed even if it operates. In addition, it may cause servo trouble. Futaba will not be responsible for damage, etc. caused by combination with the products of other companies.

In addition, the FSU Fail Safe Unit cannot be used because the system is different. Use the fail safe function of the transmitter.

- ❗ When using analog servos, always switch the T4GRS servo response to the "NORM" mode.

**Transmitter mode:**"T-FHSS(NORM)", "T-FHSS(NORM)"and FHSS mode .  
**Receiver's battery** :Matched to the ratings of the receiver and connected servo (dry cell battery cannot be used).

The set cannot operate in the "HIGH" mode. Operation in this mode will cause trouble with the servo and other equipment. Digital servos (including BLS Series brushless servos) can also be used in the "NORM" mode.



# Warning Displays

## Backup Error

### LCD screen:

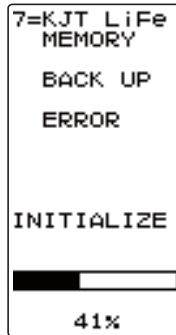

If the data is lost for an unknown reason, an audible alarm will sound and "MEMORY BACK UP ERROR" will be displayed on the LCD screen.

### Audible alarm:

**Tone will sound (9 times), then repeat.**

## Warning

**!** When a backup error is generated, immediately stop using the system and request repair from the Futaba Service Center.

If you continue to use the system, the transmitter may malfunction and cause loss of control

## Low Battery Alarm

### LCD screen:

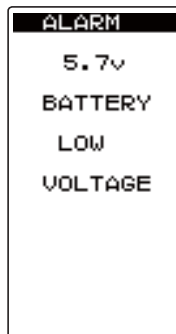

If the transmitter battery voltage drops to 4.1V (when using Futaba rechargeable type battery: 4.9V) or less, an audible alarm will sound and "BATTERY LOW VOLTAGE" will be displayed on the LCD screen.

### Audible alarm:

**Continuous tone.**

## Warning

**!** When a low battery alarm is generated, cease operation immediately and retrieve the model.

If the battery goes dead while in operation, you will lose control.

## Power supply and low battery alarm

The T4GRS can use an optional rechargeable battery. However, the battery alarm setting is different from that of the dry cell battery (alkaline battery recommended). Therefore, always set the battery type to match the power source used. Always set the battery type to "N5/L2" especially when using a Futaba rechargeable type battery. If the set is used at "DRY4" setting, the time from low battery alarm to system stopping will become extremely short.

## Memory Error

### LCD screen:

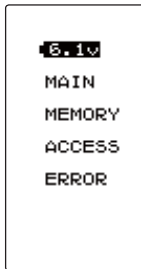

If the data in the transmitter is not transferred normally when the power is turned on, an audible alarm will sound and "MAIN MEMORY ACCESS ERROR" will be displayed on the LCD.

- To stop the alarm, turn off the power.
- Turn the power back on. If the alarm is not generated again, there is no problem.

**Audible alarm:**  
**Tone sounds (7 times) and stops (repeated)**

## MIX Warning

### LCD screen:

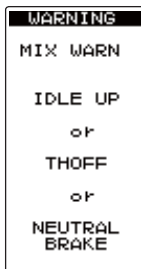

When the power switch is turned on while the idle-up, preset (engine cut) or neutral brake function switch is on, an audible alarm will sound and "MIX WARN" will be displayed on the LCD. When that function switch is turned off, the alarm will stop.

**Audible alarm:**  
**Tone sounds (7 times) and stops (repeated)**

## MIX Warning

### LCD screen:

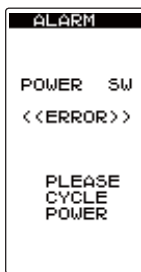

If the power switch is quickly switched from the DISP mode to the PW ON mode or vice versa, the switch error shown at the left may be generated. If this occurs, cycle the power.

**Audible alarm:**  
**Tone sounds (7 times) and stops (repeated)**

## Power off forgotten warning

### LCD screen:

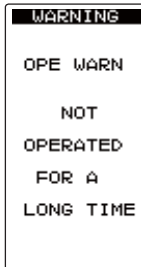

If the T4GRS is not operated for 10 minutes, an audible alarm is sounded and "OPE WARN" is displayed on the screen. The audible alarm stops when the steering stick, throttle stick, and any dial, switch, or edit button is operated. If you are not going to use the transmitter, turn the power off.

**Audible alarm:**  
**Tone sounds (7 times) and stops (repeated)**

## Throttle stick warning

\*This function only operates when in "TH-STK : F10" mode.

### LCD screen:

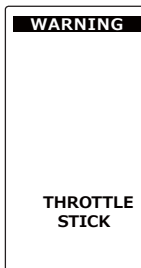

If the transmitter is switched on with the throttle stick above the slow position and alarm will sound. The alarm will stop when the stick is moved to the slow position. Ensure that the throttle stick is in the slow position when the transmitter is switched on.

**Audible alarm:**  
**Tone sounds (7 times) and stops (repeated)**

## Optional Parts

The following parts are available as 4GRS options. Purchase them to match your application. For other optional parts, refer to our catalog.

### Transmitter Battery

---

When purchasing a transmitter battery use the following:

#### Part name

HT5F1800B (6V/1800mAh) NiMH battery

FT2F1700V2(6.6V/1700mAh)/2100BV2 (6.4V/2100mAh) LiFe battery

Please do not use the transmitter batteries HT5F1800B and FT2F1700V2/2100BV2 as the receiver's battery.

Since the transmitter's battery has an overload protection circuit, the output power will be shut down when the high current load is applied. This may result in runaway or fatal crash.

Temperature Sensor (SBS-01T)

RPM Sensor (SBS-01RM)

Voltage Sensor (SBS-01V)

## When requesting repair

Before requesting repair, read this manual again and recheck your system. Should the problems continue, continue as follows.

### (Information needed for repair)

Describe the problem in as much detail as possible and send the letter along with the system in question.

- Symptom (Including the conditions and when the problem occurred)
- R/C System (Send transmitter, receiver and servos)
- Model (Type of model, brand name and model number or kit name)
- Detailed packing list (Make a list of all items sent in for repair)
- Your name, postal and e-mail address and telephone number.

### (Warranty)

Read the Warranty card.

- When requesting warranty service, send the card or some type of dated proof purchase.

## **Federal Communications Commission Interference Statement (for U.S.A.)**

This equipment has been tested and found to comply with the limits for a Class B digital device, pursuant to Part 15 of the FCC Rules. These limits are designed to provide reasonable protection against harmful interference in a residential installation.

This equipment generates, uses and can radiate radio frequency energy and, if not installed and used in accordance with the instructions, may cause harmful interference to radio communications. However, there is no guarantee that interference will not occur in a particular installation. If this equipment does cause harmful interference to radio or television reception, which can be determined by turning the equipment off and on, the user is encouraged to try to correct the interference by one or more of the following measures:

- Reorient or relocate the receiving antenna.
- Increase the separation between the equipment and receiver.
- Connect the equipment into an outlet on a circuit different from that to which the receiver is connected.
- Consult the dealer or an experienced radio/TV technician for help.

## **Compliance Information Statement (for U.S.A.)**

This device, complies with part 15 of the FCC Rules. Operation is subject to the following two conditions:

- (1) This device may not cause harmful interference, and (2) This device must accept any interference received, including interference that may cause undesired operation.
- (3) This module meets the requirements for a mobile device that may be used at separation distances of more than 20cm from human body. To meet the RF exposure requirements of the FCC this device shall not be co-located with another transmitting device.

## **CAUTION:**

To assure continued FCC compliance:

Any changes or modifications not expressly approved by the grantee of this device could void the user's authority to operate the equipment.

## **Exposure to Radio Frequency Radiation**

To comply with FCC RF exposure compliance requirements, a separation distance of at least 20 cm must be maintained between the antenna of this device and all persons. This device must not be located or operating in conjunction with any other antenna or transmitter.

---

©Copyright 2018. No part of this manual may be reproduced in any form without prior permission. The contents of this manual are subject to change without prior notice. While this manual has been carefully written, there may be inadvertent errors or omissions. Please contact our service center if you feel that any corrections or clarifications should be made.