

Daytime Fan-Aspirated Radiation Shield Kit Installation Manual

For Vantage Pro2™ & Vantage Pro2 Plus™ Stations

Introduction

The Daytime Fan-Aspirated Radiation Shield kit can be used to upgrade any Vantage Pro2 or Vantage Pro2 Plus sensor suite equipped with a passive radiation shield.

Components:

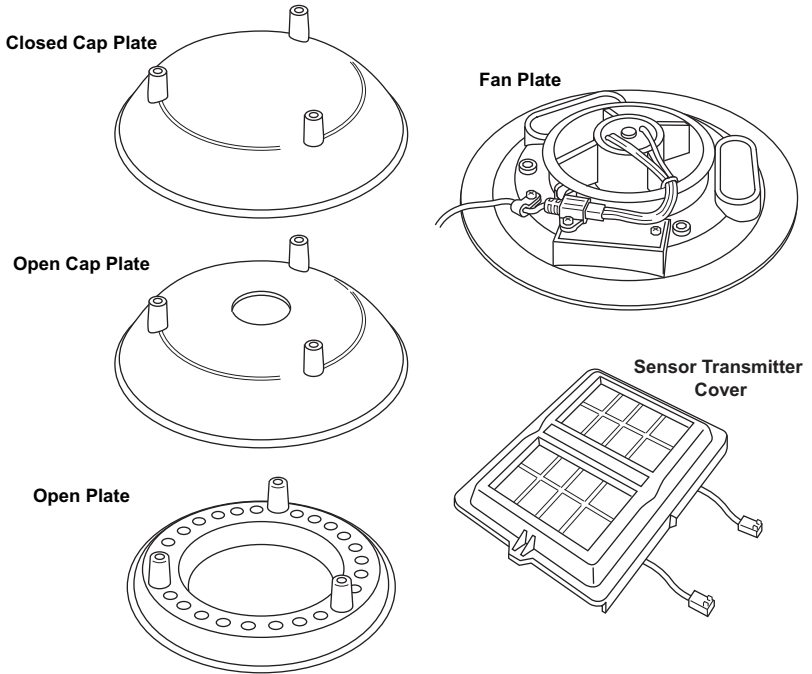

The kit also includes the following hardware:

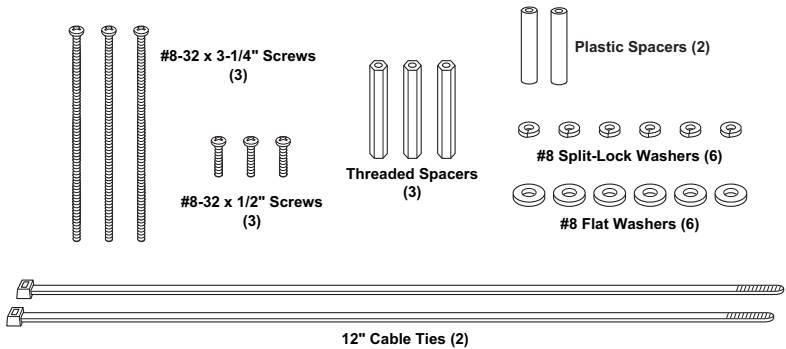

Tools Needed

You may need some or all of the following tools to complete the upgrade:

- A medium Phillips-head screwdriver
- Other tools as required to remove and re-mount the sensor suite

Prepare to Install Your Fan

Put console in Setup Mode

If you have a console, you should put it in Setup Mode. This prevents the reception of erroneous data while you are removing the sensor suite.

If you have an Envoy and are concerned with erroneous data, you may edit the data via the WeatherLink software. See the WeatherLink Online Help for more information.

To put your console in Setup Mode, press and hold the DONE key and then press the down arrow (-).

Note: If the console acquires erroneous data during the upgrade, see your console manual for instructions on clearing data.

Take down the sensor suite

If you are installing the Daytime Fan Kit on a sensor suite that has already been set up, you will need to take it down and move it to a convenient and safe place to perform the installation.

To disassemble the sensor suite:

1. Open the transmitter shelter cover.
2. Disconnect the solar panel wire from the cover.
3. Remove the foam insert from the cable access port in the lower right corner of the shelter and set it aside.
4. Disconnect the anemometer cable (labeled WIND) and the temperature/humidity sensor cable from the sensor transmitter and slide the cables out of the cable access port.
5. *Cabled sensor suites only:* Disconnect the console cable and slide it out of the cable access port.
6. You can now remove the sensor suite from its mounted position. Move it to a safe place to install the Daytime Fan.

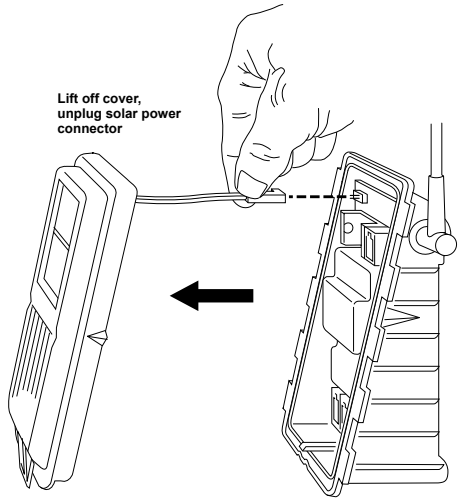

Disassemble the standard radiation shield

Note: We recommend using a workbench or table to perform the following procedures.

1. Remove the rain collector cone from the sensor suite base by rotating the cone counter-clockwise. When the cone's latches line up with openings in the base, you can lift the cone off. The cone fits in the base tightly and may require extra pressure to remove the first few times.

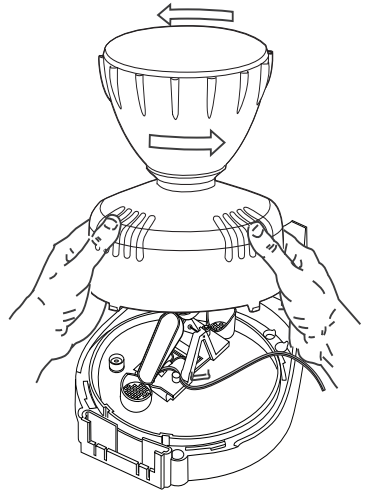

Tip: Steady the sensor suite base between your knees when removing the cone

- Remove the three 8-32 x 4" screws holding the radiation shield plates together. **Save these three screws and washers.**

Separate out the radiation plating. *The illustration at left is of a newer model of Vantage Pro2. See below if your temperature/humidity sensor is installed in a different position.*

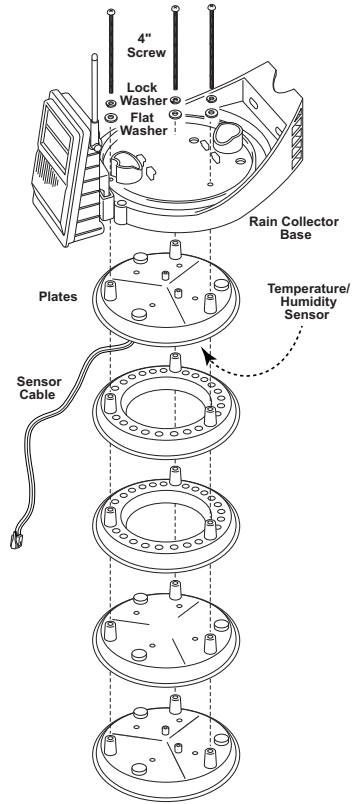

Move the temperature/humidity sensor

Most newer model sensor suites have the temperature/humidity sensor mounted on the underside of the top plate, as shown in the above illustration. On older models the sensor may be mounted on a different plate. In any case, unless the sensor is already mounted on the second to bottom-most plate of the radiation plating stack, on spacers, and facing **down**, you will need to uninstal it and reinstall as directed below.

- Locate the plate at the top of the radiation shield plating and find the insulating disk with the temperature/humidity sensor on the underside of the radiation shield.

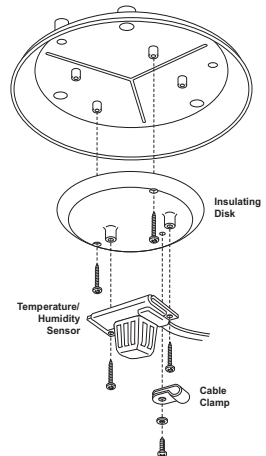

2. Remove the three screws, flat washer, and cable clamp securing the temperature/humidity sensor to the insulating disk. Save the small screw and flat washer for use later.
3. Remove the two screws holding the insulating disk attached on the underside and discard the disk.
4. Reinstall the sensor facing down on the second to bottom-most radiation plate, using the two 1" plastic spacers and #4 screws included with the kit.
5. Replace the radiation plate back in its correct place in the radiation shield plating stack.

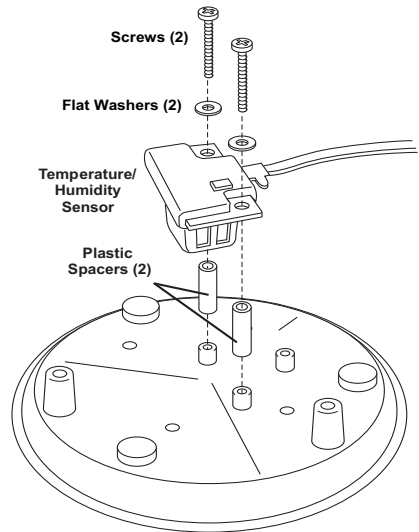

Note: You do not need to use a cable clamp on the sensor cable when mounted on this plate.

Assemble the Lower Section

Once the existing radiation shield has been disassembled and the Temperature/Humidity sensor has been mounted correctly in the radiation plating stack, the existing disks have to be re-organized and assembled with the fan-aspirated kit.

1. Build the lower section of the new radiation shield by stacking six plates; in this order, from the bottom up:
 - 1: The original bottom plate.
 - 2: The disassembled original top plate (with the insulating disc removed).
 - 3: The plate containing the temperature/humidity sensor.
 - 4 & 5: The two open plates on top of the two bottom plates.
 - 6: The third open plate (supplied with the fan-aspirated kit).

Note: When stacking plates, make sure their screw standoffs line up with each other.



-
2. Run the temperature/humidity cable up through the center of the three open plates.
 3. Set aside the re-assembled radiation shielding and find the fan plate motor assembly.
 4. Attach the three threaded spacers to the fan plate using the three #8-32 x 1/2" screws and the three #8 washers and #8 lock washers included with the kit.

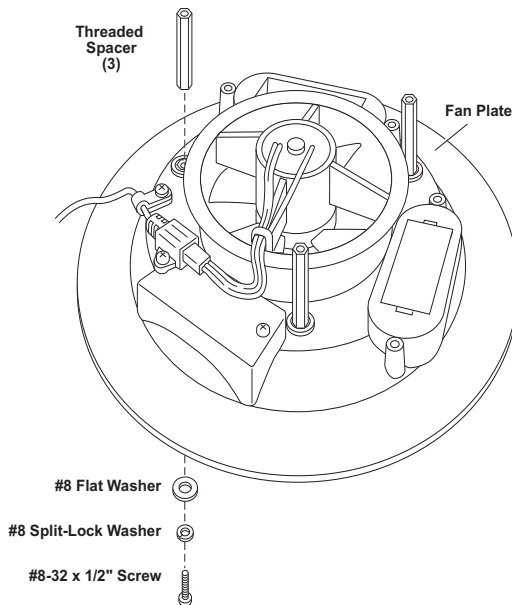

5. Detach the fan motor cable from the power cable assembly on the fan plate, lift the fan motor out and set it aside.

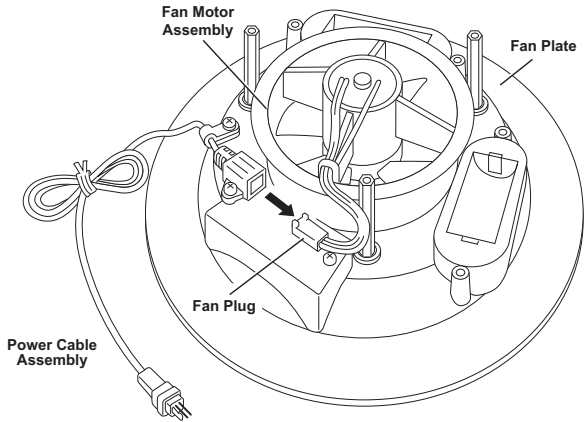

6. Place the fan plate onto the radiation shielding stack.

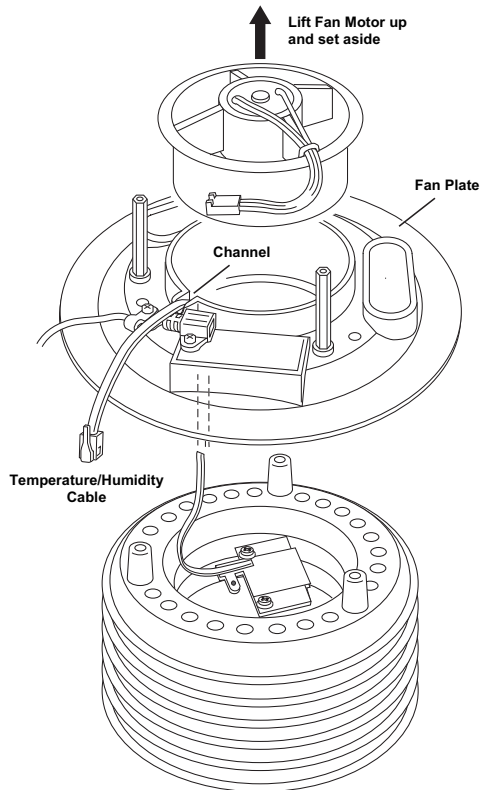

7. Bring the temperature/humidity cable over the top of the fan plate with as little slack as possible and press it firmly into the cable channel on the fan plate.

8. Place one of the 4" screws removed from the original radiation shield and its corresponding #8 lock washer and # 8 flat washer into one of the radiation shield plate holes on the fan plate located just counter-clockwise from a threaded spacer, making sure the screw goes through the standoff in each of the plates and lines up with the threaded standoff located in the bottom plate.

9. Turn the screw to engage the threaded insert in the bottom plate.

10. Make sure the other screw standoffs are aligned and then insert the other two 4" screws and corresponding washers in the same way.

11. Tighten all three screws to securely fasten the bottom section of the radiation shield.

12. Place the fan motor back into place and plug the fan motor cable back into the power cable assembly.

13. Unscrew the cable clamp holding the power cable assembly in place.

14. Thread the temperature/humidity sensor cable into the cable clamp and tighten the screw back down in its original placement.

15. Place the cap plates on top (with the closed one on top) of the rest of the radiation shield and line up their standoffs.

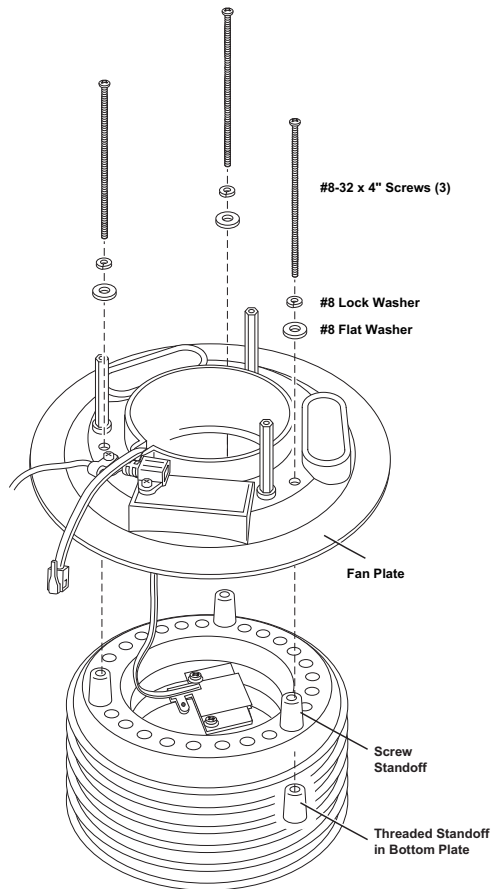

16. Insert one of the 3 1/4" screws and corresponding lock and flat washers included in the kit hardware into one of the holes in the sensor suite base as show below.

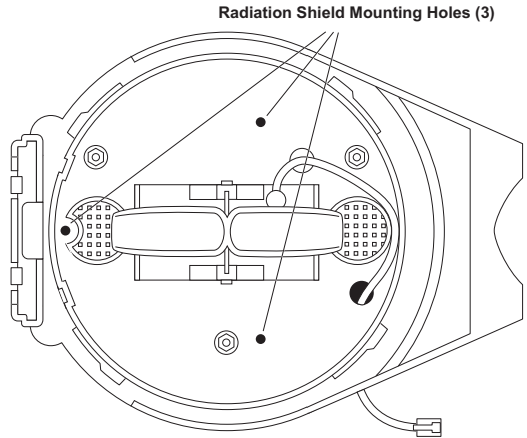

17. Lower the sensor suite base onto the stack so that the screw goes through the standoffs and into the threaded spacers. Turn the screw a few times to engage the threads.
18. Place a lock washer and flat washer on the other two 3 1/4" screws then insert them through the other two screw holes.
19. Tighten all three screws to securely fasten the radiation shield to the sensor suite base.

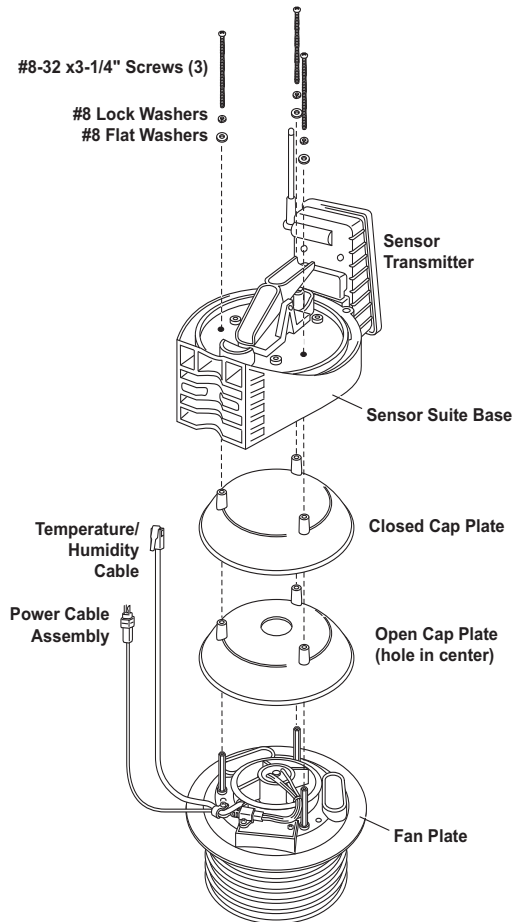

Finishing Steps

1. Install the rain collector cone and lock it in place.
2. Slide the fan unit's power cable, the anemometer cable, and the temperature/humidity sensor cable and through the cable access port of the sensor transmitter.

Tip: *If you have trouble getting all the sensor cables into the access port, make sure all the installed cables are pushed to the left of the access port. Try inserting the three cables through the access port in this order: fan power cable, anemometer cable, temperature/humidity cable.*

3. Reconnect the temperature/humidity sensor cable.
4. Close the sensor transmitter cover temporarily without connecting the solar panel cables.
5. Test communication between the sensor suite and the console. To test communication, take the console out of Setup Mode and make sure the console is receiving data from the sensor suite. See your sensor suite manual for more information on testing communication.
6. Reinstall the sensor suite in its previous location.
7. Open the sensor transmitter cover and discard it.
8. Reconnect the WIND (anemometer) cable.
9. **Cabled sensor suites:** Connect the console cable.
10. Find the new sensor transmitter door that came with your fan kit. Connect the wire coming from the top solar panel on the cover to the sensor transmitter board as shown below.

Note: This wire is not needed on cabled Vantage Pro2. For cabled systems, you should secure it where it will not interfere with the SIM box.

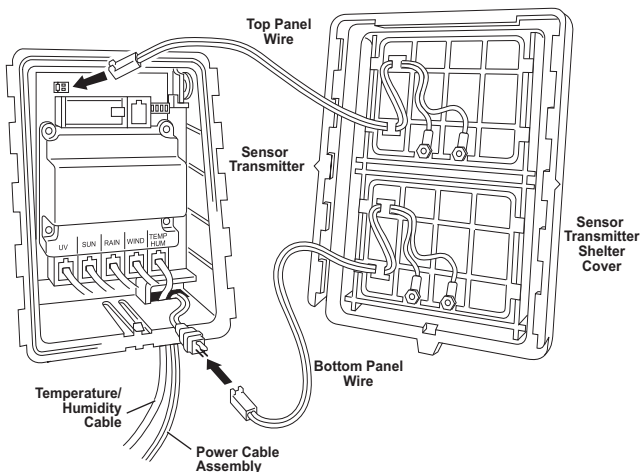

11. Connect the wire coming from the bottom solar panel to power cable assembly in the sensor transmitter.
12. Reinsert the foam into the cable access port in the sensor transmitter.
13. Close the sensor transmitter.
14. Use cable ties to secure cables.
15. Make sure the fan blades are rotating by directing the transmitter cover to sunlight or by shining a bright incandescent light on the solar panel.
You should hear a slight whir if the fan is running.

Tip: *Make sure to take the console out of Setup Mode. Refer to your Vantage Pro2 Console Manual for more information on clearing any erroneous data from the console.*

Guidelines for Securing Cables

- Secure cables so they will not whip in the wind.
- Secure cables to metal poles by using a cable tie or by wrapping electrical tape around them both.
- Place clips or ties approximately every 3 to 5 feet (1 to 1.6 m).
- If needed, additional cable ties, cable tie mounts, and other hardware can be obtained at a hardware or electronics store.

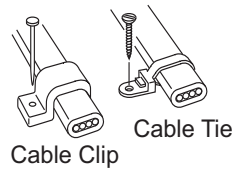

Securing Cables

Note: Do not use metal staples or a staple gun to secure cables. Metal staples—especially when installed with a staple gun—have a tendency to cut the cables.

Maintenance

- Keep the surfaces of the shield and solar panel clean, since they are less effective when dirty. Remove dust from the solar panel and radiation shield with a damp cloth.
- Remove any debris obstructing air flow through the radiation shield such as leaves, twigs, webs, and nests.
- Do not spray the sensor suite with insecticides of any kind. Some insecticides can damage the sensors and even damage the radiation shield.

Annual Maintenance

We recommend cleaning out any debris that may have accumulated inside the radiation shield and replacing the motor (# 7758) on an as-needed basis. The routine procedures for annual maintenance include:

1. Remove your fan-aspirated sensor suite and place on a stable work surface.
2. Check to see if the fan motor is still working. If it is not running, replace the motor with a new motor (# 7758).
3. Disassemble the radiation shield.
4. Remove any debris lodged inside the unit.
5. Clean the surfaces of the radiation shield with a damp cloth.

-
6. Reassemble the radiation shield.
 7. Re-install the sensor suite in its previous location.

Contacting Davis Instruments

For questions about installing or operating your Daytime Fan-Aspirated Radiation Shield, please contact Davis Technical Support. We'll be glad to help.

Note: Please do not return items to the factory for repair without prior authorization.

FCC Part 15 Class B Registration Warning

This equipment has been tested and found to comply with the limits for a Class B digital device, pursuant to Part 15 of the FCC Rules. These limits are designed to provide reasonable protection against harmful interference in a residential installation. This equipment generates, uses, and can radiate radio frequency energy and, if not installed and used in accordance with the instructions, may cause harmful interference to radio communications.

However, there is no guarantee that interference will not occur in a particular installation. If this equipment does cause harmful interference to radio or television reception, which can be determined by turning the equipment on and off, the user is encouraged to try to correct the interference by one or more of the following measures:

- Reorient or relocate the receiving antenna.
- Increase the separation between the equipment and receiver.
- Connect the equipment into an outlet on a circuit different from that to which the receiver is connected.
- Consult the dealer or an experienced radio/TV technician for help.

Changes or modification not expressly approved in writing by Davis Instruments may void the warranty and void the user's authority to operate this equipment.

EC EMC Compliance

This product complies with the essential protection requirements of the EC EMC Directive 2004/108/EC.

FC Tested to comply
with FCC standards
FOR HOME OR OFFICE USE



Daytime Fan-Aspirated Radiation Shield, #7747

7395.236 Rev. D, 2/25/19

Vantage Pro® and Vantage Pro2™ are trademarks of Davis Instruments Corp., Hayward, CA.
Davis Instruments Quality Management System is ISO 9001 certified.

© Davis Instruments Corp. 2019. All rights reserved.

Information in this document subject to change without notice.

DAVIS ®
Davis Instruments