

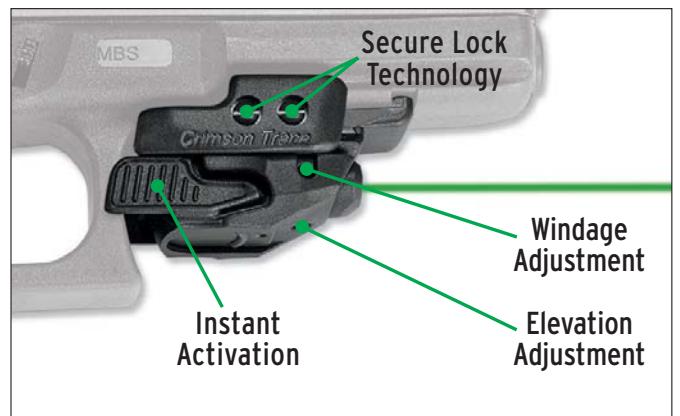

**PRODUCT SPECIFICATIONS**

BEAM INTENSITY: 5mW peak, 515-532 nm, Class 3R laser  
 DOT SIZE: Approximately 0.5 inches diameter at 50 feet  
 BATTERIES: One (1) 1/3N 3V lithium battery; over two hours of illumination  
 ACTIVATION: Instant Activation™ - Tap On, Tap Off with auto shut off at five minutes  
 WARRANTY: Three-year full warranty  
 This product complies with 21 CFR 1040.10



**! WARNING**

FAILURE TO FOLLOW ANY OF THE FOLLOWING WARNINGS MAY RESULT IN SEVERE INJURY OR DEATH TO YOU OR OTHERS.

Prior to installing Crimson Trace™ products, ensure that the firearm is unloaded, the magazine is removed, safety on and finger(s) off the trigger.

**DO NOT** install or use Crimson Trace product if the installation of the product in any way affects the safe function of the firearm.

**ALWAYS FOLLOW THE 4 RULES OF FIREARM SAFETY:**

1. Handle all firearms as if they are loaded.
2. Never let the muzzle cover anything that you are not willing to destroy.
3. Keep your finger off the trigger until your sights are on the target and you are ready to fire.
4. Be sure of your target and what is beyond.

Remember, the user is **ALWAYS** responsible for the safe use of a firearm.

Crimson Trace recommends that every gun owner take a gun safety course from a certified NRA Instructor before handling or firing your firearm.

**LASER SAFETY LABELING**

**IMPORTANT: LASER PRODUCTS MUST ONLY BE OPERATED WITH THE SAFETY LABEL APPLIED TO THE FIREARM.**

- A. Attach the “Danger” warning label to the outside of the firearm.
- B. Attach the “Aperture” warning label with the arrow pointing to the laser aperture.

Use caution when activating the laser to avoid direct eye exposure, which can result in permanent eye damage. Follow all precautions as outlined by the firearms manufacturer. Keep this and all firearm related products locked and secured from children or other unauthorized users.

**WARNING:** This product contains chemicals known to the state of California to cause cancer, or birth defects or other reproductive harm.

Crimson Trace holds several patents and may have other patents pending that cover its innovations. Please review individual products for patent numbers to determine the specific patent coverage.

## DETERMINING FIT

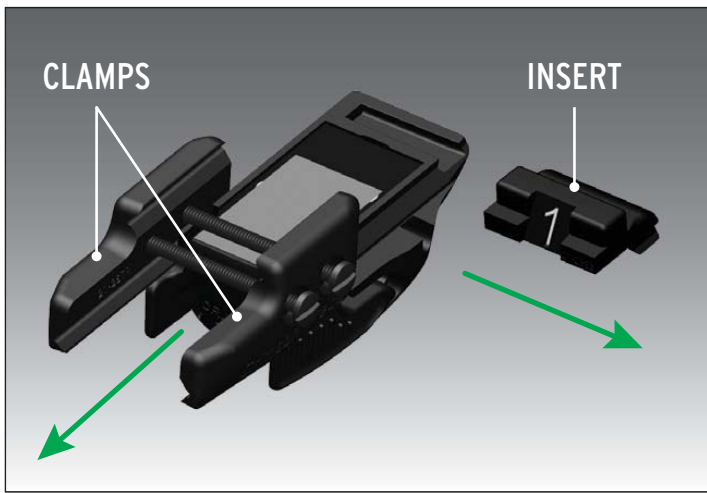

1. Turn screws counter clockwise to loosen. Slide clamps away from Insert. Remove Insert #1 by sliding to the right.

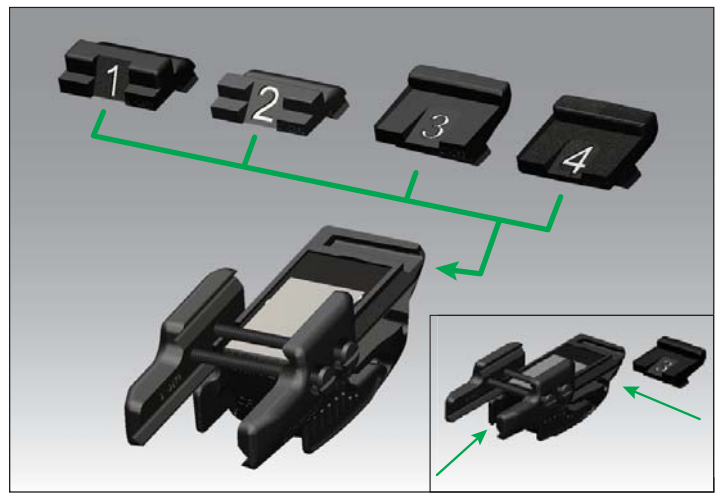

2. Multiple inserts will accommodate your gun frame. Select the insert that works best ergonomically as each insert will change the position of the instant activation buttons. Refer to chart below for popular models. Slide clamps back into place (see inset).

## INSTALLATION INSTRUCTIONS

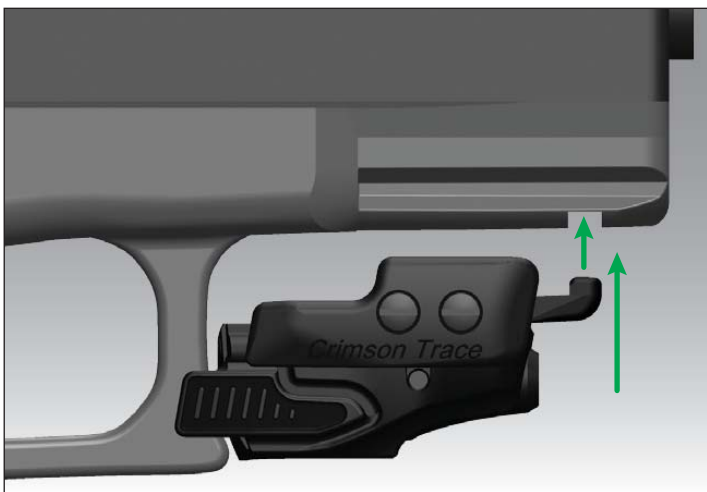

1. Align Rail Master® at desired rail lug for easy tap on/tap off activation.

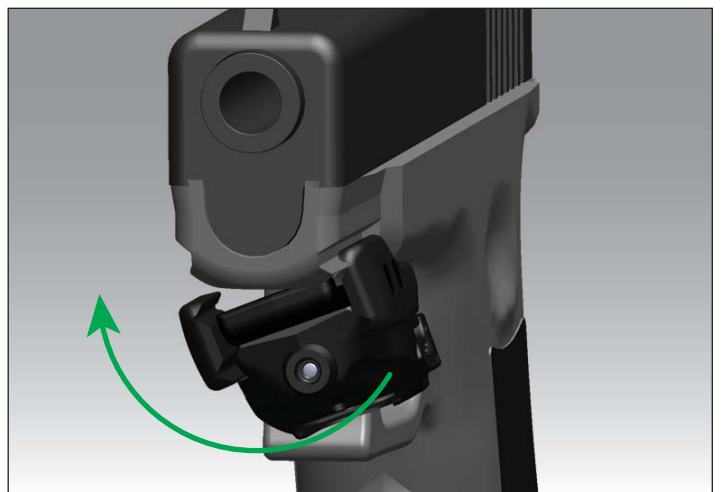

2. Attach Rail Master at desired location on firearm rail and rotate into place, aligning insert with rail lug. Turn screws clockwise to secure clamps to rail.

## BATTERY INSTALLATION

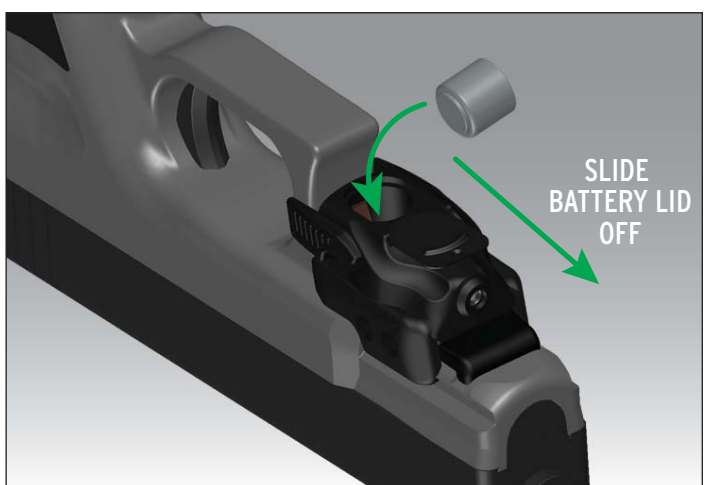

1. Remove Battery Lid. Place provided battery negative (-) side toward rail. Slide battery lid back into slot.

## ACTIVATION & MODES

Confirm that laser and iron sights are in alignment. The laser dot should rest on top of front site post with correct iron sight picture. See windage and elevation adjustments to fine tune or adjust for any point of impact. See Sighting figure to right.\*

The Rail Master has been programmed with 3 Activation Modes for full user adaptability. It has been factory set to the Constant-On mode.

- > **Constant-On:** Laser will stay on after single tap of either Instant Activation button; tap again to turn off.
- > **Momentary:** Laser will only stay on while either Instant Activation button is depressed.
- > **Strobe:** Laser will stay on after single tap of either Instant Activation button; tap again to turn off.

To select desired Mode, press both activation buttons at the same time for 3 seconds to cycle through the modes; release buttons at desired mode. When changing between Constant-On and Momentary modes, a slight pulse will occur indicating mode change.

When left on, the Rail Master will remain on for 5 minutes before automatically shutting off (as indicated by a quick pulse of the laser at the end of five minutes).



# FIT & INSERT NUMBER CHART (FOR MOST POPULAR MAKES/MODELS)

YOUR RAIL MASTER COMES WITH 4 INSERTS TO ACCOMMODATE MULTIPLE FIREARM PLATFORMS.

GUN MANUFACTURER	INSERT #	GUN MANUFACTURER	INSERT #	GUN MANUFACTURER	INSERT #
<b>BERSA</b> BP CC ..... 2 Thunder Pro ..... 2		<b>HECKLER &amp; KOCH</b> P30 ..... 1*, 3*, 4* 45C ..... 1 P2000 ..... 3 *Multiple inserts will accommodate gun.		<b>SPRINGFIELD ARMORY</b> XD9, XD40 Sub-Compact ..... 2 XD40 ..... 4 XD9, XD9 Tactical ..... 2 XD9 MOD2 3" ..... 2 XDM - 5.25, 4.5, 3.8 ..... 2 XD-S ..... 2 XD-S 4.0 ..... 2	
<b>BERETTA</b> PX4 Compact ..... 2 PX4, 92, 96 ..... 4		<b>RUGER</b> SR9c, SR40c ..... 2 SR9, SR40 ..... 3 SR22 ..... 2		<b>TAURUS</b> Millennium Pro ..... 2 24/7 ..... 4	
<b>FN</b> 5.7 ..... 4 P9 ..... 3 P45 ..... 3 FNX-40 ..... 3		<b>SIG SAUER</b> P220, P226, P229, P250, P2022 ... 1, 4		<b>WALTHER</b> P22-Q ..... 2 PK380 ..... 2 P99 ..... 2 PPQ ..... 4 PPS ..... 2	
<b>GLOCK</b> Full and Compact Models with Rails ..... 3		<b>SMITH &amp; WESSON</b> MP9C, MP40C ..... 1, 4 MP9, MP40 ..... 1 MP22 ..... 1 SD9, SD40 ..... 4		<b>ACCESSORY RAILS</b> AR/M16/Rifles/Shotguns with M1913 Picatinny Accessory Rail, Weaver Accessory Rail ..... 1	

## WINDAGE & ELEVATION ADJUSTMENTS

Crimson Trace laser sights are pre-sighted at the factory. Many times no further adjustments are required. All products are fully adjustable for windage and elevation if further adjustments are desired. A good starting point is to align the laser with the fixed sights on the firearm. (Figure 1).

A two-screw alignment system is used to adjust for windage and elevation. The adjustment screws are located just behind the laser source, use the supplied allen wrenches to make any adjustments. Refer to the figure below and reference your particular model for sighting instructions.

Start by lining your laser sight up with your fixed sights at a desired distance. Most people sight in their laser at between 20 and 50 ft. However because of the offset between the laser sight and the bore, the actual change in point-of-impact at these distances is very small.

Further adjustments can be made at the range to determine where your bullet impacts in relation to your firearms fixed sights. The laser should be moved to the actual impact point of the bullet (Figure 2).

**DO NOT OVERTURN THE ADJUSTMENT SCREWS. A little adjustment goes a long way. Rarely is more than a half turn required to make your needed adjustments.**

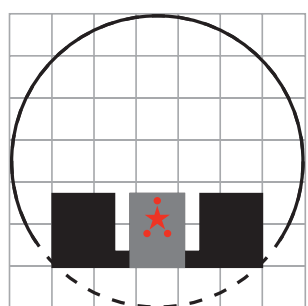

FIGURE 1: BEAM LINED UP WITH PROPER SIGHT PICTURE.

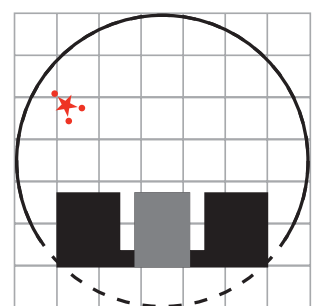
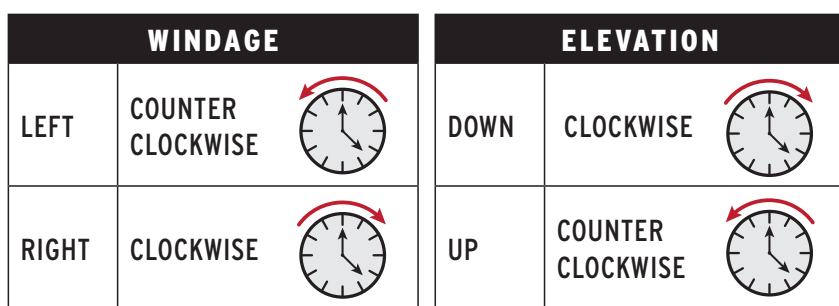

FIGURE 2: BEAM MOVED TO LINE UP WITH IMPACT POINT.

## MAINTENANCE

Laser sights require minimal attention and are designed to resist most common firearm chemicals and lubricants, however, excessive exposure to these chemicals can be detrimental. To ensure the safe and effective operation of your laser sights:

- > Remove Laser Sight before cleaning gun.
- > Do not use pressurized or compressed air.
- > Do not immerse in cleaning fluid or lubricate firearm excessively. A firearm that has too much oil will foul the lens of the laser and result in an unfocused beam. This can be easily cleaned and causes no permanent damage.
- > Do not allow cleaning solution to enter lens source.
- > Do not allow solvents to contact your grips that contain: VOCs or TCE such as: carb/brake cleaner, acetone, MEK, gasoline. Grip damage will result.
- > Crimson Trace diodes are designed and positioned to minimize exposure. Occasional cleaning of the lens is recommended.

After extensive shooting, you may notice a degradation of beam quality or "beam spread". This is the result of fouling on the lens surface. This is normal and can be easily cleaned with the included cleaning swabs or a small cotton swab dipped in isopropyl alcohol or window cleaner. Dry the lens with a clean dry swab. When cleaning the lens do not touch lens with any sharp objects.

**WARNING:** This product contains chemicals known to the state of California to cause cancer, or birth defects or other reproductive harm.

Looking for dependable gun sights? Rely on Crimson Trace for quality and long-lasting products.