



**PRODUCT SPECIFICATIONS**

**LIGHT INTENSITY:** 100 lumen LED  
**BATTERIES:** One (1) CR2 lithium battery; over two hours of illumination  
**ACTIVATION:** Instant Activation™ - Tap On, Tap Off with auto shut off at five minutes  
**WARRANTY:** Three-year full warranty  
 This product complies with 21 CFR 1040.10



**! WARNING**

**FAILURE TO FOLLOW ANY OF THE FOLLOWING WARNINGS MAY RESULT IN SEVERE INJURY OR DEATH TO YOU OR OTHERS.**

Prior to installing Crimson Trace products, ensure that the firearm is unloaded, the magazine is removed, safety on and finger(s) off the trigger.

**DO NOT** install or use Crimson Trace product if the installation of the product in any way affects the safe function of the firearm.

**ALWAYS FOLLOW THE 4 RULES OF FIREARM SAFETY:**

1. Handle all firearms as if they are loaded.
2. Never let the muzzle cover anything that you are not willing to destroy.
3. Keep your finger off the trigger until your sights are on the target and you are ready to fire.
4. Be sure of your target and what is beyond.

Remember, the user is **ALWAYS** responsible for the safe use of a firearm.

Crimson Trace recommends that every gun owner take a gun safety course from a certified NRA Instructor before handling or firing your firearm.

**WARNING:** This product contains chemicals known to the state of California to cause cancer, or birth defects or other reproductive harm.

Crimson Trace holds several patents and may have other patents pending that cover its innovations. Please review individual products for patent numbers to determine the specific patent coverage.

## DETERMINING FIT

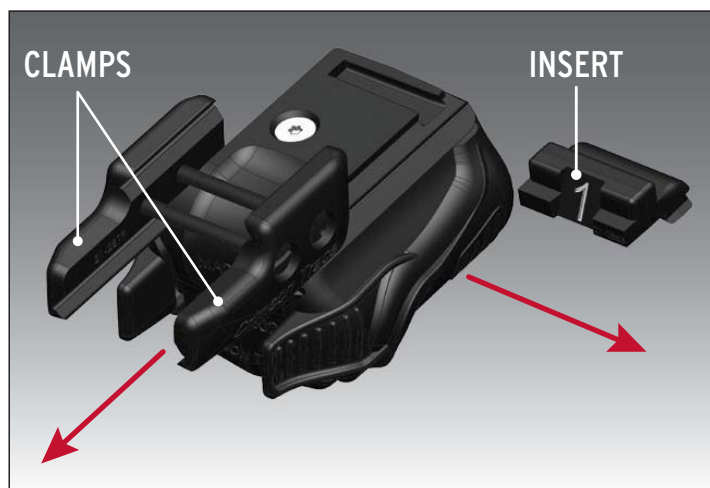

1. Turn screws counter clockwise to loosen clamps. Slide clamps away from Insert. Remove Insert #1 by sliding to the right.

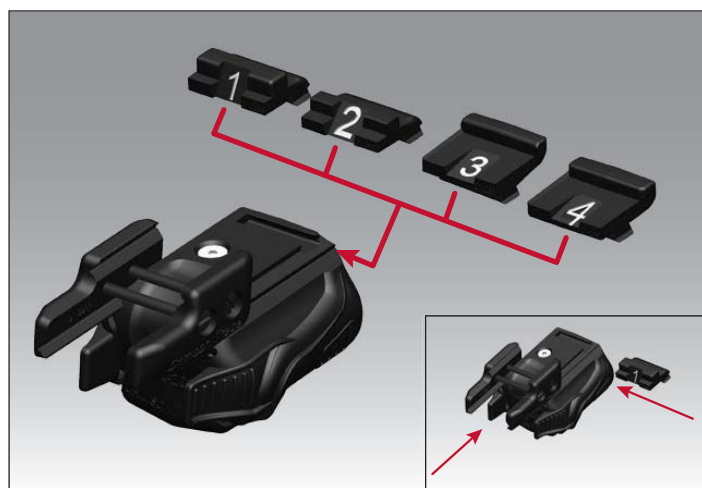

2. Multiple inserts will accommodate your gun frame. Select the insert that works best ergonomically as each insert will change the position of the instant activation buttons. Refer to chart below for popular models. Slide clamps back into place (see inset).

## INSTALLATION INSTRUCTIONS



1. Align Rail Master at desired rail lug location for easy tap on/tap off activation.



2. Attach Rail Master at desired location on firearm rail and rotate into place, aligning insert with rail lug. Turn screws clockwise to secure clamps to rail.

## BATTERY INSTALLATION

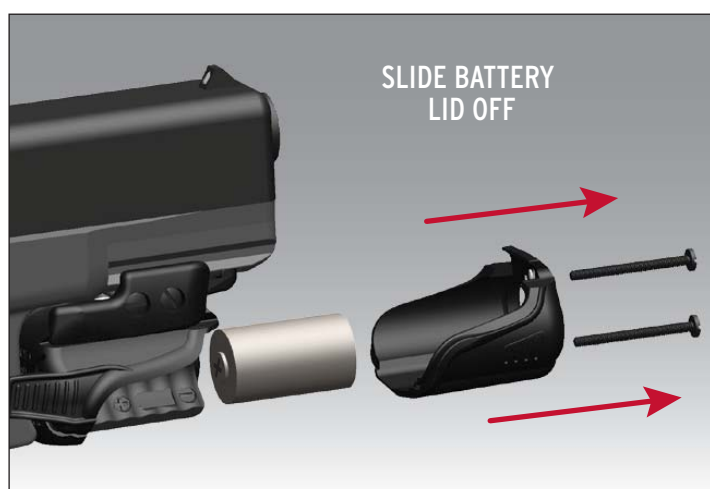

1. Remove Battery Lid. Place positive (+) end toward activation tabs and slide cover back into place.
2. When a fresh battery is installed correctly, a short pulse of light will occur indicating correct battery installation.
3. When battery is replaced, desired light mode will not be changed.

## ACTIVATION & MODES

The Rail Master has been programmed with 3 Activation Modes for full user adaptability. It has been factory set to the Constant On mode.

- > **Constant On:** Light will stay on after single tap of either Instant Activation button; tap again to turn off.
- > **Momentary:** Light will only stay on while either Instant Activation button is depressed.
- > **Strobe:** Light will stay on after single tap of either Instant Activation button; tap again to turn off.

To select desired Mode, press both activation buttons at the same time for 3 seconds to cycle through the modes; release buttons at desired mode. When changing between Constant On and Momentary modes, a slight pulse will occur indicating mode change.

When left on, the Rail Master will remain on for 5 minutes before automatically shutting off (as indicated by a quick pulse of the light at the end of five minutes).

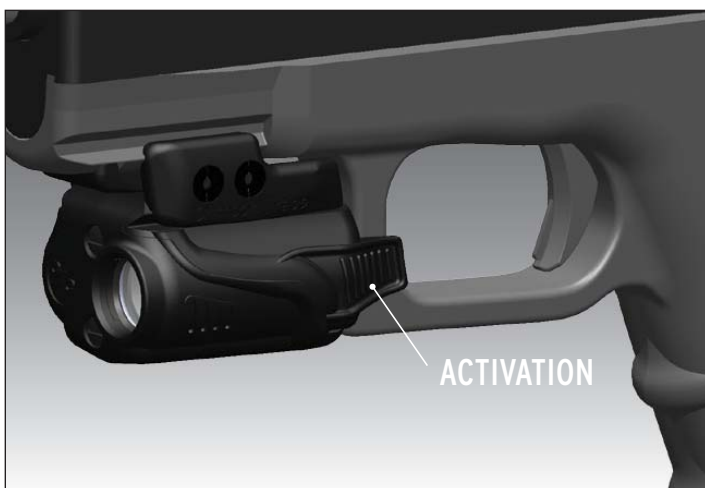

# FIT & INSERT NUMBER CHART (FOR POPULAR MAKES/MODELS)

GUN MANUFACTURER	INSERT #	GUN MANUFACTURER	INSERT #	GUN MANUFACTURER	INSERT #
<b>1911</b> 1911 with Rails* . . . . .	1, 4	<b>KEL-TEC</b> PF9 . . . . .	1, 2	<b>SPRINGFIELD</b> XD9, XD40 Sub-Compact* . . . . .	2
<b>BERSA</b> BP9CC . . . . . Thunder Pro . . . . .	2 2	<b>HECKLER &amp; KOCH</b> P30 . . . . . 45C . . . . . P2000 . . . . .	4 1 3	XD9, XD9 Tactical* . . . . . XDM* - 5.25, 4.5, 3.8 . . . . .	2 2, 3
<b>BERETTA</b> PX4 Compact . . . . . PX4 Full-Size . . . . . 92*, 96* . . . . .	2 4 4	<b>RUGER</b> SR9c, SR40c . . . . . SR9, SR40 . . . . . SR22 . . . . .	2 3 2	<b>TAURUS</b> Millennium Pro . . . . . 24/7 . . . . .	1, 2 2, 4
<b>FN</b> FN 5.7 . . . . . P9/40/45 . . . . . FNX . . . . .	4 3 1	<b>SIG SAUER</b> P220* . . . . . P226* . . . . . P229* . . . . . P250 . . . . . P2022* . . . . .	1, 4 1, 4 1, 4 1, 4 1, 4	<b>WALTHER</b> P22-Q . . . . . PK380 . . . . . P99, PPQ, PPS (with single recoil slot) . . . . . P99 P99, PPQ, PPS (with multiple recoil slots) . . . . .	2 2 4 2
<b>GLOCK</b> Full-Size* . . . . . Compact* . . . . .	3 3	<b>SMITH &amp; WESSON</b> MP Full-Size* . . . . . MP Compact* . . . . . SD9, SD40 . . . . .	1, 4 1 1, 4	<b>ACCESSORY RAILS</b> AR/M16/Rifles/Shotguns with M1913 Picatinny Accessory Rail, Weaver Accessory Rail . . . . .	1

\* Indicates the CMR-202 is compatible with CTC Lasergrips®.

YOUR RAIL MASTER COMES WITH 4 INSERTS TO ACCOMMODATE MULTIPLE FIREARM PLATFORMS.

## MAINTENANCE

Your Rail Master Light requires minimal attention and is designed to resist most common firearm chemicals and lubricants, however, excessive exposure to these chemicals can be detrimental. To ensure the safe and effective operation of your light:

- > Remove Rail Master Light before cleaning gun.
- > Do not use pressurized or compressed air.
- > Do not immerse in cleaning fluid or lubricate firearm excessively. A firearm that has too much oil will foul the lens of the light and result in an clouded beam. This can be easily cleaned and causes no permanent damage.
- > Do not allow cleaning solution to enter lens source.
- > Do not allow solvents to contact your Rail Master that contain: VOCs or TCE such as: carb/brake cleaner, acetone, MEK, gasoline. Damage will result.
- > Crimson Trace lights are designed and positioned to minimize exposure. Occasional cleaning of the lens is recommended.

After extensive shooting, you may notice a degradation of light beam quality. This is the result of fouling on the lens surface. This is normal and can be easily cleaned with a small cotton swab dipped in isopropyl alcohol or window cleaner. Dry the lens with a clean dry swab. When cleaning the lens do not touch lens with any sharp objects.