

INSTALLATION AND OPERATING INSTRUCTIONS

Children's electric cars

⚠ WARNING:

Assembly by an adult.
This toy is unsuitable for children under
3 years due to its maximum speed.

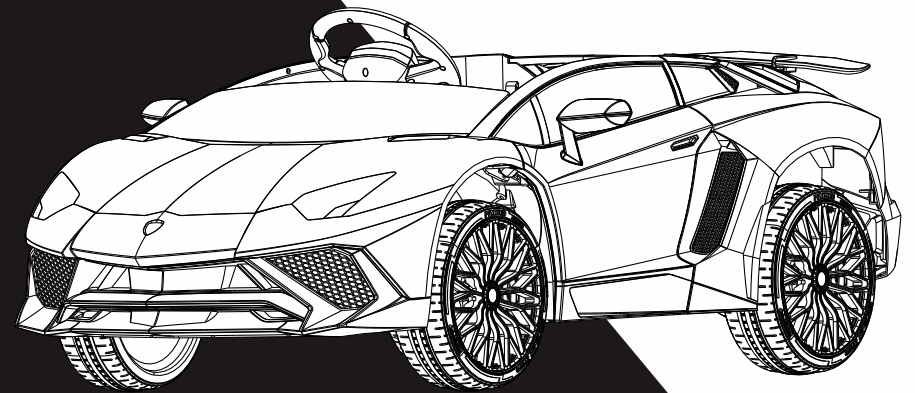

Executive standard:
En71 and En62115
ASTM F963-16

Photos are for reference ONLY.

INSTALLATION INSTRUCTION

The illustrations in this instruction are used for easier understanding of the operation method of the product and the product structure. Please note there may be differences between the pictures and the physical item.

In order to improve the quality, we may change part of the structure and appearance of the product without an advance notice.

⚠ Please read the instructions carefully before use, it will tell you the right operation method and installation steps. Incorrect operation may damage the product, or even hurt your child. Please keep this instruction ready and easy to find.

1 Safety

⚠ WARNING!

The owner's manual contains assembly, use and maintenance instructions. The vehicle must be assembled by an adult who has read and understands the instructions in this manual. Keep the packaging away from children and dispose of all packaging before use.

Note: For best performance use on flat, hard surfaces.

The following safety hazards may result in serious injury or death to the user of the vehicle:

- This product contains small parts that are for adult assembly only. Keep small children away when assembling. Remove and dispose of all protective material and poly bags before assembly. Be sure to remove all packaging materials and parts from underneath the vehicle body.
- Battery posts, terminals and related accessories contain lead and lead compounds (acids) chemicals known to the state of California to cause cancer, reproductive harm, and are toxic and corrosive. Never open the battery.
- Body parts such as hands, legs, hair and clothing can get caught in moving parts. Never place a body part near a moving part or wear loose clothing while using the vehicle. Always wear shoes when using the vehicle.
- This toy does not have brakes or any braking capability. Do not leave a child unattended while using this toy or allow use of this toy in any location that requires braking capability, as this could result in a roll away or loss of control, which may cause serious injury or death.
- Using the vehicle near streets, motor vehicles, drop-offs such as: steps,

water (swimming pools) or other bodies of water, sloped surfaces, hills, wet areas, flammable vapors, in alleys, at night or in the dark could result in an unexpected accident. Always use the vehicle in a safe, secure environment with continuous adult supervision.

- Using the vehicle in unsafe conditions such as snow, rain, loose dirt, mud, sand or fine gravel may result in unexpected action such as tip over and skidding, and damage to the electrical system and battery.
- Using the vehicle in an unsafe manner. Examples include but are not limited to:
 - a. Pulling the vehicle with another vehicle or similar device
 - b. Allowing more than one rider
 - c. Pushing the user from the back
 - d. Traveling at an unsafe speed

Always use common sense and safe practices when using the vehicle

BATTERY WARNINGS

⚠ WARNING!

The following safety hazards may result in serious injury or death to the user of the vehicle:



- Use of a battery or charger other than the supplied 12V rechargeable battery and charger may cause a fire or explosion. Only use the supplied 12V rechargeable battery and charger with the vehicle.

- Using the 12V rechargeable battery and charger for any other product may result in overheating, fire or explosion. Never use the 12V rechargeable battery and charger with another product.

- Explosive gases are created during charging. Charge the battery in a well ventilated area. Do not charge the battery near heat or flammable materials.

- Contact between the positive and negative terminals may result in fire or explosion. Avoid direct contact between the terminals. Picking up the battery by the wires or charger can cause damage to the battery and may result in a fire. Always pick up the battery by its case or handles.



- Liquids on the battery may cause fire or electric shock. Always keep all liquids away from the battery and keep the battery dry.



- Contact or exposure to battery leakage (lead acid) may cause serious injury. If contact or exposure occurs immediately call your physician. If the chemical is on the skin or in the eyes, flush with cool water for 15 minutes. If the chemical was swallowed,

immediately give the person water or milk. Do not give water or milk if the patient is vomiting or has a decreased level of alertness. Do not induce vomiting.

- Battery posts, terminals and related accessories contain lead and lead compounds (acid), chemicals known to the State of California to cause cancer, reproductive harm and are toxic and corrosive. Never open the battery.
- Tampering or modifying the electric circuit system may cause a shock, fire or explosion and permanently damage the system. Exposed wiring, circuitry in the charger may cause electric shock. Always keep the charger housing closed.



USER REQUIREMENTS AND WARNINGS

Age	37-96 months
Max Weight	(30 kgs)

Before using the vehicle the child should understand the vehicle controls and safety issues. They must also demonstrate the capability to handle the vehicle and operate its controls. It is the responsibility of the adult to educate the child and supervise the vehicles use. Read the following safety warnings to any child using the vehicle before riding.

⚠ WARNING!

- Never leave child unattended. Always supervise the child.
- Always sit in the seat when using the vehicle.
- Keep your hands, hair and clothes away from moving parts.
- Always wear shoes when using the vehicle.
- Only one rider is allowed on the vehicle at a time
- Children under 3 years of age cannot use the vehicle.
- Only drive on level ground.
- Do not go near swimming pools or other bodies of water, drop-offs or up and down steep inclines.
- Do not drive the vehicle into loose dirt, mud, sand or fine gravel.
- Do not drive the vehicle on streets or near cars.
- Not to be used in traffic.

CARE WARNINGS

⚠ WARNING!

- Park the vehicle indoors or cover it with a tarp to protect it from wet weather.
- Do not leave the vehicle in the sun for long periods of time or fading may occur. Store in shade or cover with tarp.
- Do not wash the vehicle with a hose.
- Do not wash the vehicle with soap and water.

RE-CHARGE INTERVAL AND TIME Important!









- Damage to the battery may occur if it is allowed to drain completely. Do not allow the battery to drain completely.
- Check the battery and charger (supply cord, connector) for wear and damage before charging. Do not charge the battery if damage has occurred.
- On average you will need to charge the battery between 8 and 12 hours. Do not charge the battery for more than 20 hours. Failure to charge the battery as directed could cause permanent damage to the battery and void the warranty.
- Only an adult who has read and understands the safety warnings should handle, charge and recharge the battery.

Specification

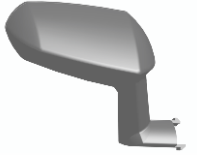
Name	specification
Battery and fuse	(Recoverable fuse: 7A/15A) Battery: 12V 4.5AH (6-FM-4.5 (AH)) *1 12V 7AH (6-FM-7 (AH)) *1 12V 10AH (6-FM-10 (AH)) *1
Motor	Motor: 12V (Rotational Speed:14000r/min) Steering motor:12V (Rotational Speed:6000r/min)
Suitable age	37-96 months
Maxweight	30KG
Body size	1310*725*480MM
Speed	3-6KM/h
Hours of use	charging 8-12hours, using 1 to 2hours
Charger	Input: 110V~240V Output: DC 12V500MA DC 12V700MA DC 12V1000MA
Mainmaterial	PP(polypropylene) and iron

*The above parameters contain optional features, specific parameters please refer to our samples.

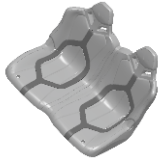
Parts List

NO	QTY	PICTURE	NO	QTY	PICTURE
①	1	 A (Steering Wheel)	②	1	 B (Instruction Book)
③	1	 C (Mirror L)	④	1	 D (Mirror R)
⑤	1 (optional)	 E (Remote control)	⑥	1	 F (Rearwing)
⑦	4	 G (Wheel)	⑧	4	 H (Small Wheel Cover)
⑨	1	 I (Seat)	⑩	2	 L (M8 Spanner)

*Photos are for reference ONLY.

Installation Steps

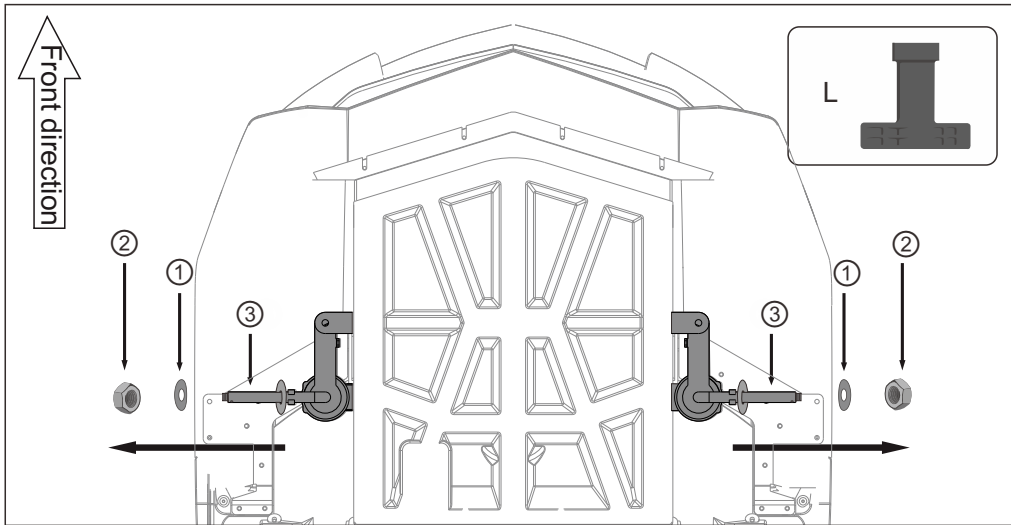

Install front wheel one:

Use L (M8 spanner) to loose ②(M8 nuts) from ③(front axle) (counterclockwise rotation), and take down ①(M8 shim).

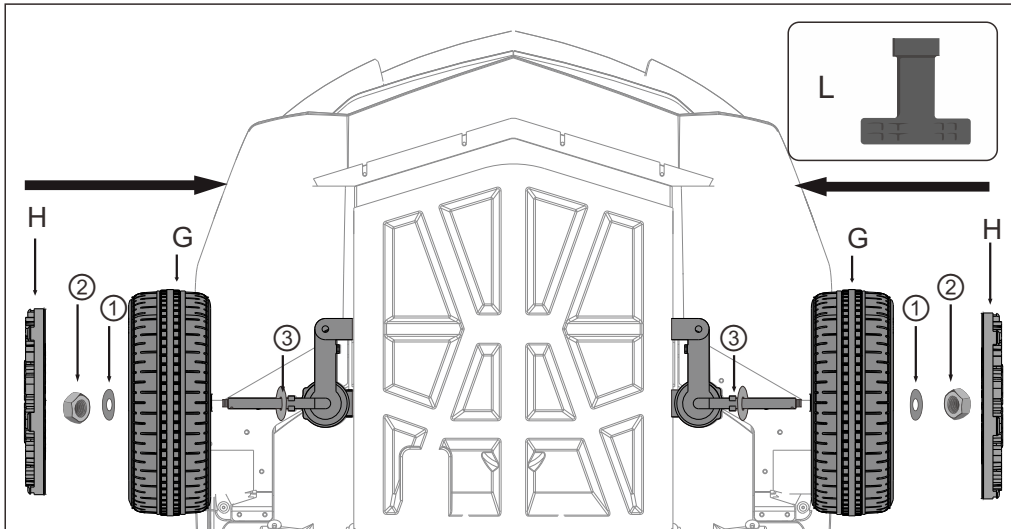

Install front wheel two:

Install G(wheel) onto the ③(front axle) as shown in the figure, then place ① (M8 shim) on ③(front axle). Use L(M8 spanner) to fix ②(M8 nut) on ③(front axle) (clockwise rotation).then install H(small wheel cover) onto the right place on G(wheel).

7

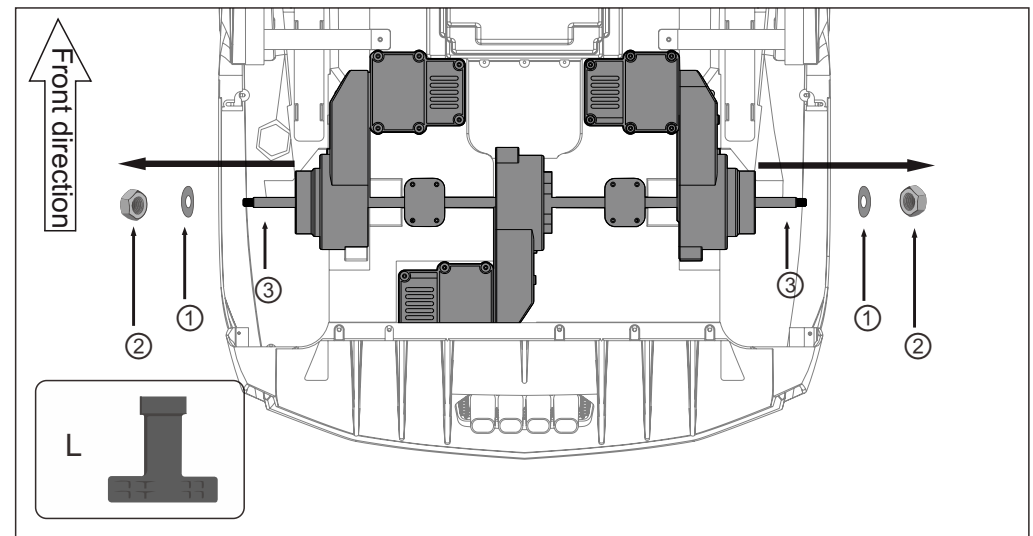

Install rear wheel one:

Use L (M8 spanner) to loose ②(M8 nuts) from ③(rear axle) (counterclockwise rotation), and take down ①(M8 shim).

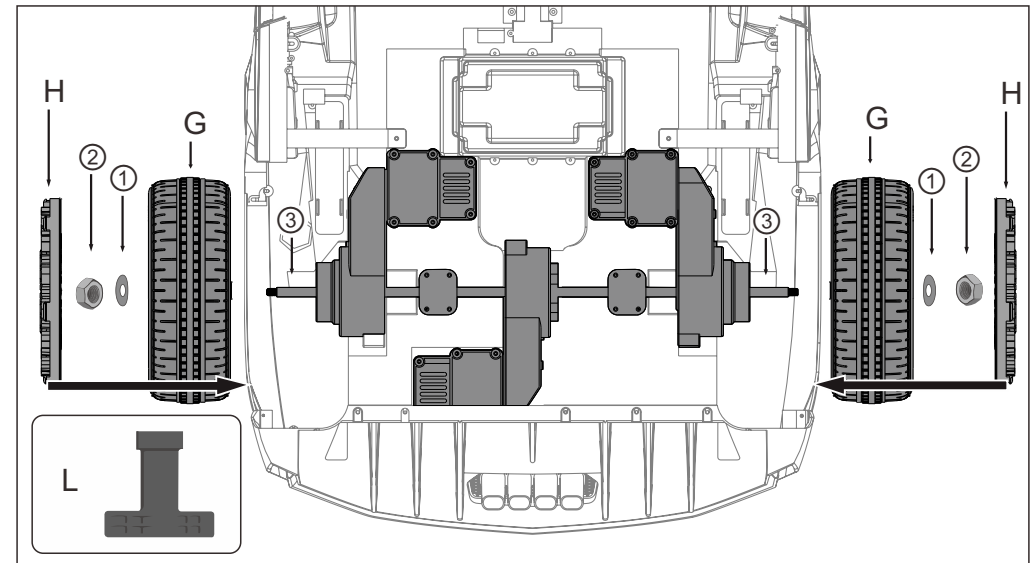

Install rear wheel two:

Install G(wheel) onto the ③(rear axle) as shown in the figure, then place ① (M8 shim) on ③(rear axle). Use L(M8 spanner) to fix ②(M8 nut) on ③(rear axle) (clockwise rotation).Then install H(small wheel cover) onto the right place on G(wheel).

8

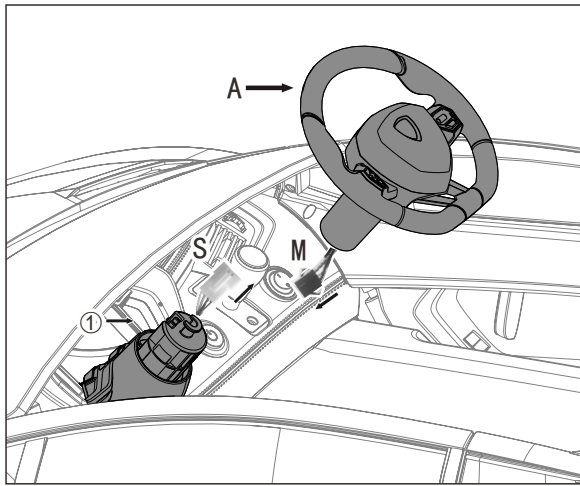

Install Steering Wheel:

Connect SM terminal first, place and fix A (steering wheel) on ① steering yoke as shown in figure.

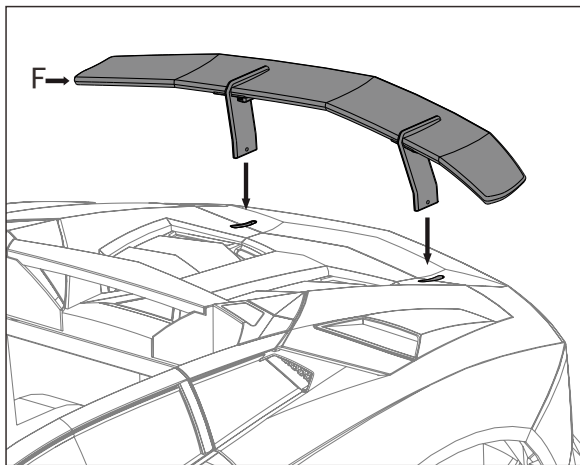

Install Rear Wing:

Place and fix F (rear wing) onto the right place as shown in figure.

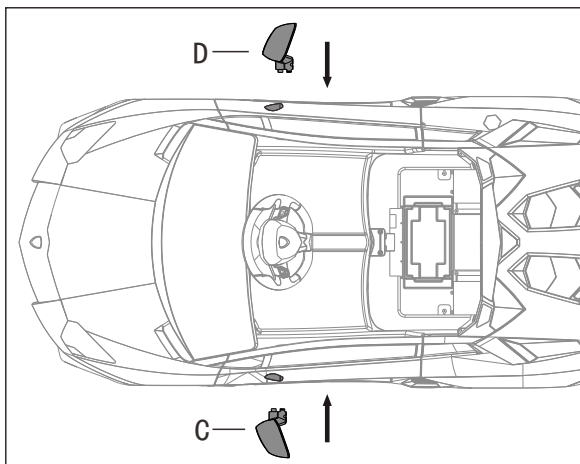

Install Mirror:

Place and fix C (Mirror L), D (Mirror R) onto the right place as shown in figure.

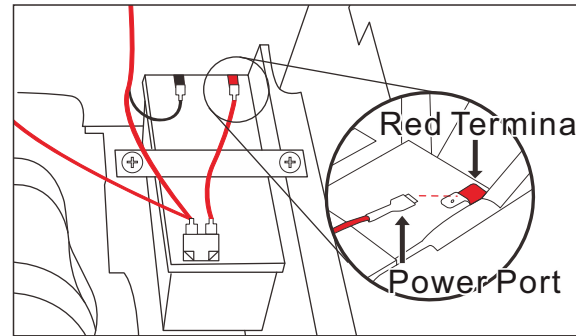

Power Connection:

find the positive electrode (the red port pointed by arrow in figure) connect it to the red terminal

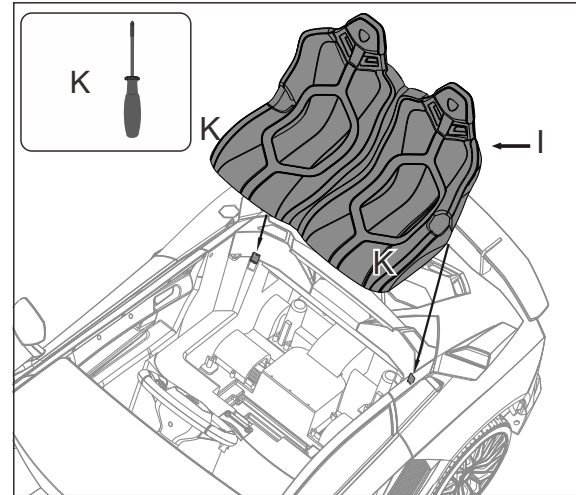

Install seat:

Place I (seat) onto the right place, fix the two hooks (on the back of the seat) into the corresponding on carbody. Then tighten two K (self-tapping screws) to fix the seat.

Direction for use

1. The installation and replacement of the batteries in the remote control:

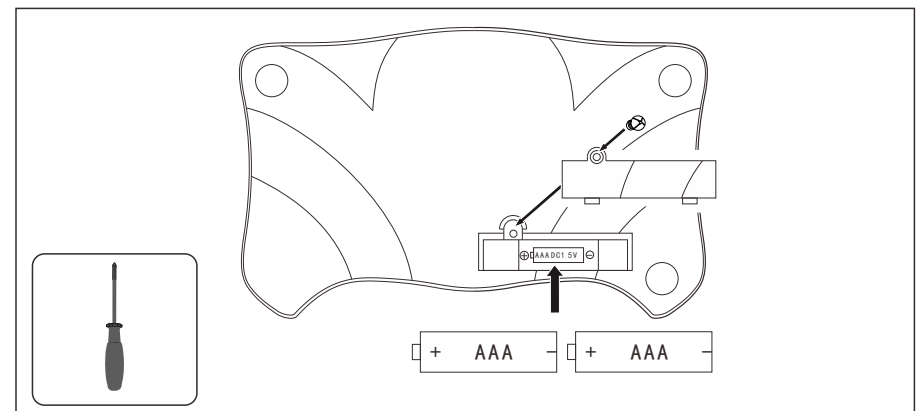

⚠ WARNING!

1. All batteries should be inserted in the correct polarity.
2. Non-rechargeable battery cannot be recharged
3. Before charging, the rechargeable battery must be taken out from the toys.
4. Take out and properly deal with the dead battery. To avoid injury, please keep kids away from the battery.
5. The direct contact between the positive and negative terminals may result in fire or explosion. Avoid direct connect between the terminals.
6. Do not mix old and new batteries. DO not mix alkaline, standard (carbon-zinc), or rechargeable (nickel-cadmium) batteries.
7. Only an adult who has read and understood the safety warnings can recharge the battery.

Use a screwdriver to remove the battery cover of the remote control, insert two AAA 1.5V dry batteries in correct polarity. Close the battery cover and fix it with the screw. (Battery replacement also according to the above steps)

2. Matching the frequency of car and remote control

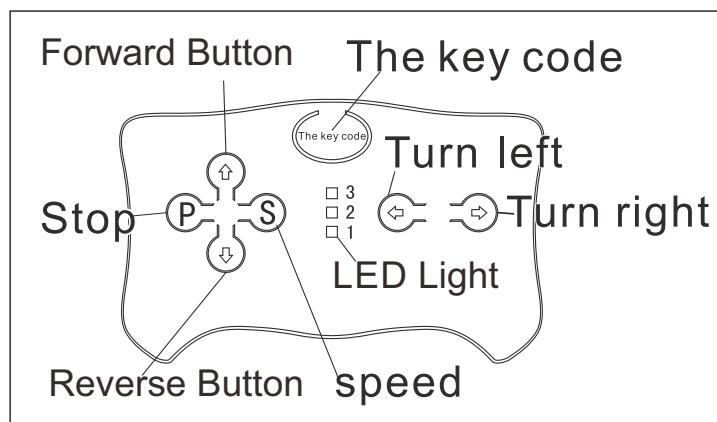

The remote control operation always prior to the foot pedals operation. (The foot pedal won't work while operating remote control)

Operation manual: For the first time to use (Or Replace the battery) Need to frequency bind

- Take out the remote control, install the battery
- Long press on the frequency key 2-4 seconds, Low speed LED lights will flash
- Turn on the power of the car, Low speed LED lights will from flash to long lighting, then frequency bind succeed
- If the frequency bind failed (Low speed LED lights flash), remove the battery and repeat steps 1-3
- Remote control without operation after 10 seconds, indication light will off into power saving mode
- Button Description: \triangle forward ∇ backward \triangleleft turn left \triangleright turn right

S: Speed P: emergency brake, press it and the running function will fail, press again, it release

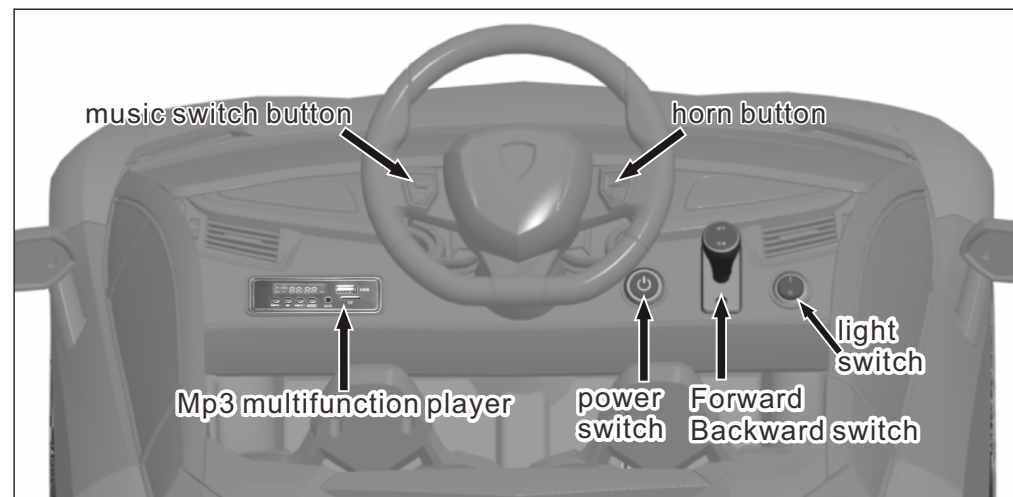

3. Operation guide for Manual control (forward, backward):

After the driver is seated, press the power switch, the car will send out a starting sound (2-5 seconds). Put the Forward/Backward switch into the position of "forward" (Press forward), step on the foot switch the car will move forward, loosen the pedal the car will stop. Put the Forward/Backward switch into the position of "Backward", step on the foot switch the car will move backward, loosen the pedal the car will stop.

4. Instruction for MP3 multifunction player

- a) The usage of button: (◀/V-) button: short press to play the last music, long press to decrease volume. (▶/V+) button: short press to play the next music, long press to increase volume. (▶||) button: pause button, in FM mode press this button will automatically search channel. (MODE) button: mode switch button, can switch among USB, TF, FM and the conventional music mode.
- b) Instruction for USB port: Plug USB into the USB port, the car will read and play the music in USB.
- c) Instruction for TF card slot: Plug TF card into the TF card slot, the car will read and play the music in TF card.
- d) Instruction for FM: Press MODE button switch mode to FM, the light of FM will on. Then press (▶||) button, the car will automatically search channel and will play the first channel after searching. Press (◀/V-) button to play the last channel, press (▶/V+) to play the next channel. (the music switch button has the same function)

5. The usage of the music switch and the horn button

Press the music switch to play different music. Press the horn button to play trumpet sound.

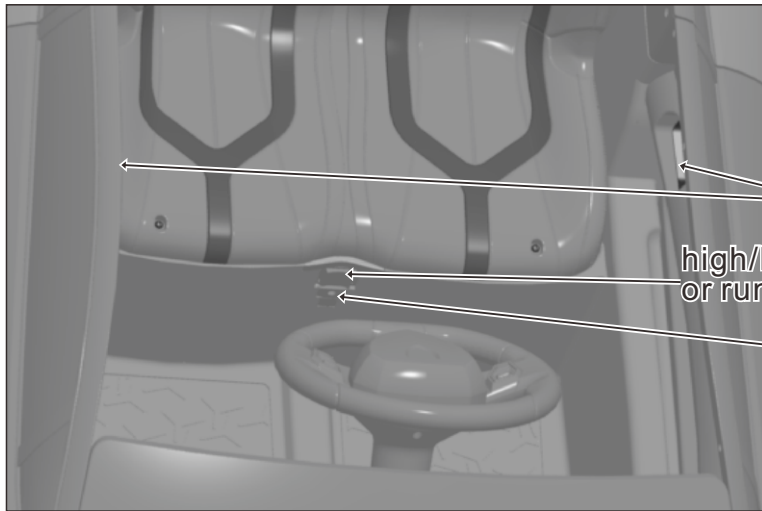

door switch
high/low speed switch or run
Charging Jack

6. The illustration of High/Low Speed

The hi/lo speed switch into the position of "low speed", step on the foot switch the car will move forward slowly, loosen the pedal the car will stop. Put the hi/lo speed switch into the position of "high speed", step on the foot switch the car will move forward fast, loosen the pedal the car will stop.

7. Instructions of the recoverable fuse

When the current exceeds 10 amperes, the recoverable fuse will automatically cut off the power supply for 5-10 seconds, then the current will be resupplied. (optional)

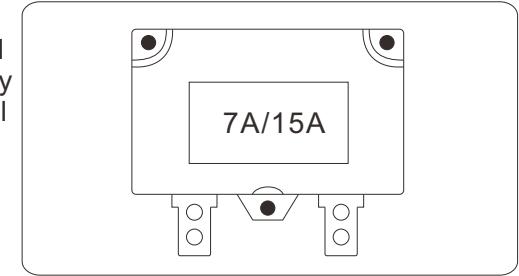

a simple circuit diagram for the collocation of 2.4G remote control and double drive

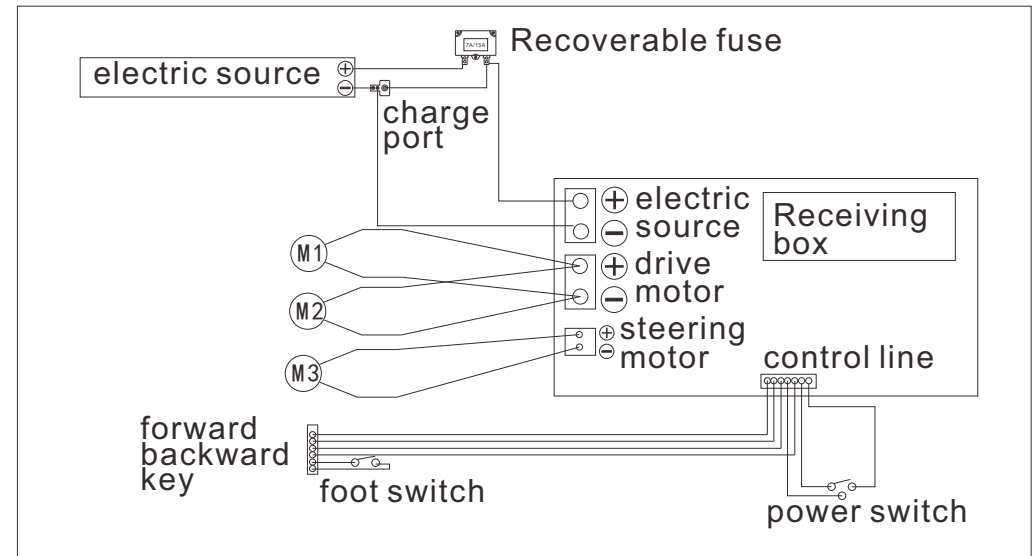

8.Charging instructions.

⚠ WARNING!

Please plug wall charger directly into a wall outlet. Do not use an extension cord.



When battery power is low, please charge it immediately. The charging port is under the seat. (Note: toys can not be operated in the charging state. Toys should be charged under adult supervision).

Troubleshooting

Fault type	Reason analysis	Elimination methods
The car did not move	<ol style="list-style-type: none"> 1. Low battery voltage 2. Electric protection 3. Switch is not reaching the correct position 4. The Battery connector fell off or loosened 5. The battery was broken 6. The appliance was broken 7. The motor was broken 	<ol style="list-style-type: none"> 1.Recharge the battery 2.Stop using for a few minutes 3.Use it according to the directions 4.Re-plug 5.Go to the maintenance point 6.Go to the maintenance point 7.Go to the maintenance point
The battery cannot be recharged	<ol style="list-style-type: none"> 1. The Battery connector fell off or loosened 2. The charger not connected to the socket 3.The charger was broken 	Reconnect Plug the charger into the socket Replace the charger
Distance per charge is too short	<ol style="list-style-type: none"> 1. The battery does not have a full charge 2. The battery is too old 	Recharge the battery Replace the battery
The batteries get warm and make a slight noise during charge	<ol style="list-style-type: none"> 1. Normal chemical reaction 	Normal
Slow speed	<ol style="list-style-type: none"> 1. The battery is too old 2. The batteries were wearing out 3.overload 4.The road is not flat 	Use a new battery Recharge the battery lighten the load to less than 25kg Drive on a neat pavement
Big noise from the gear box	<ol style="list-style-type: none"> 1.The gear was broken 	Go to the maintenance point
Shake when the car is driving	<ol style="list-style-type: none"> 1. Poor wire contact of the motor 2. Dead point on the motor 	To reconnect Go to the maintenance point
The car is silent	<ol style="list-style-type: none"> 1.The steering wheel connector is not inserted 	Connect it follow the instruction
The car cannot stop	<ol style="list-style-type: none"> 1. The motor was broken 	Go to the maintenance point