



PRODUCT SPECIFICATIONS

OPERATING AND MAINTENANCE INSTRUCTIONS

Technical Specifications

Operating Conditions and Limits

Operator's Instructions

Residual Risks

How and how often periodical fitness inspections should be conducted

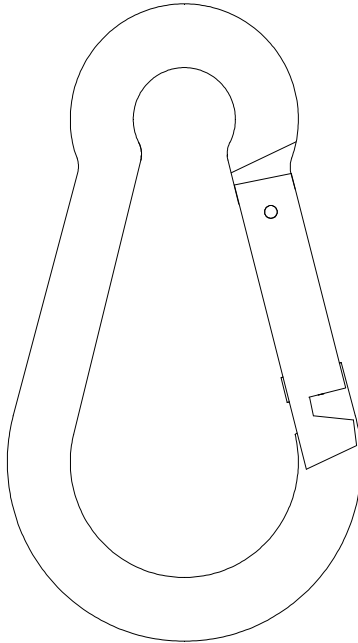

**CARABINE HOOKS
DIN 5299 ITEM 8074**

The original language of this technical specification is Italian

1) TECHNICAL SPECIFICATIONS OF ACCESSORY

Reference Standard: **Carabine hooks:** DIN 5299
Material: S235JR - UNI EN 10025-2

Surface Treatment: Galvanized A2E EN ISO 4042

The test is performed on the basis of in-house specifications and rules in accordance with UNI EN ISO 9001.

DIMENSIONAL SPECIFICATIONS:

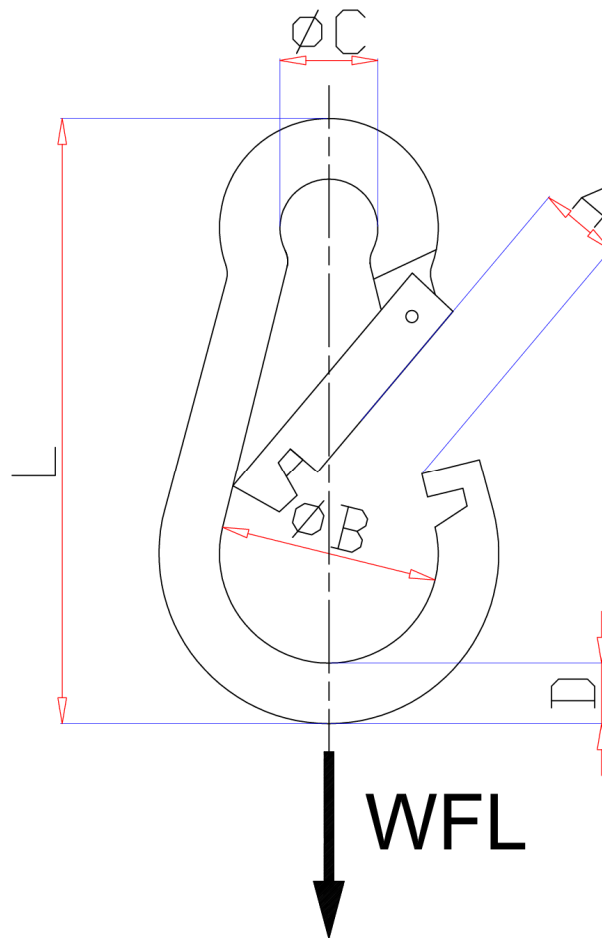



TABLE "A"

MISURA $\varnothing D \times L$	A	$\varnothing B$	$\varnothing C$	 g	WFL kg	 n	CODICE
*4 x 40	6	12	6	8	20	100	080740040
5 x 50	7	15	7	16	30	100	080740050
6 x 60	8	17	8	27	40	100	080740060
7 x 70	9	21	10	43	60	50	080740070
8 x 80	11	24	12	65	75	50	080740080
9 x 90	12	27	14	90	100	25	080740090
10 x 100	13	30	15	130	120	25	080740100
11 x 120	16	35	20	184	140	20	080740101
12 x 140	22	45	20	262	140	15	080740102
13 x 160	24	50	23	348	200	10	080740103
*14 x 180	32	60	26	445	250	10	080740104

*** SIZES NOT CONSIDERED IN DIN 5299**

All measurements are expressed in mm.

**WFL = WORKING FORCE LIMIT
SAFETY COEFFICIENT: 4**

Definitions:

- **WFL** (working force limit): the maximum force the item can support (along the main axis, if not otherwise specified) under operating conditions.
- **Safety coefficient:** guaranteed minimum breaking force to working force limit ratio.
- **Part:** part of either a component or a subsystem. Parts include ropes, straps, connecting parts, accessories and anchorage lines.
- **Inspection:** visual testing of the state of the hook, to check for clear damage or wear which may affect its use.
- **Accurate examination:** visual inspection performed by a trained person, supported, if need be, by any other instruments, including non-destructive testing, to check for damage or wear which may affect the use of the hook.
- **Trained person:** a designated, suitably trained person who has proper know-how and practical expertise and has been given the instructions needed to perform any required tests and examinations.

CAUTION: The safety coefficient is only provided by way of example, in relation to product safety. The working force limits (WFL) shown in the table should never be exceeded.

2) TESTING SPECIFICATIONS

The accessory is subjected to several stringent spot checks for serviceability, performance and compliance with specifications.

The number of samples and the related sampling plans are chosen according to the characteristic to test under UNI ISO 2859/1, and the results are filed in the quality department of the factory in Sulmona.

2.A Dimensional test

Making sure that the dimensions of the item meet such tolerances as established in in-house working drawings.

2.B Visual test

Testing for defects resulting from manufacturing, mechanical working and correspondence between the marking and in-house drawings.

2.D Tensile stress tests

Making sure that the accessory subjected to tensile stress will break, after the applied force has at least exceeded the working load as multiplied by the safety coefficient.

The test is performed in accordance with UNI 10002/1.

3) HOW TO READ MARKINGS

The accessory carries indelible marks and codes which identify the product and define the specifications and applications.

- 1) Size (e.g. 9x90)
- 2) Manufacturer's mark (ROBUR)
- 3) WFL (e.g. 100 Kg)

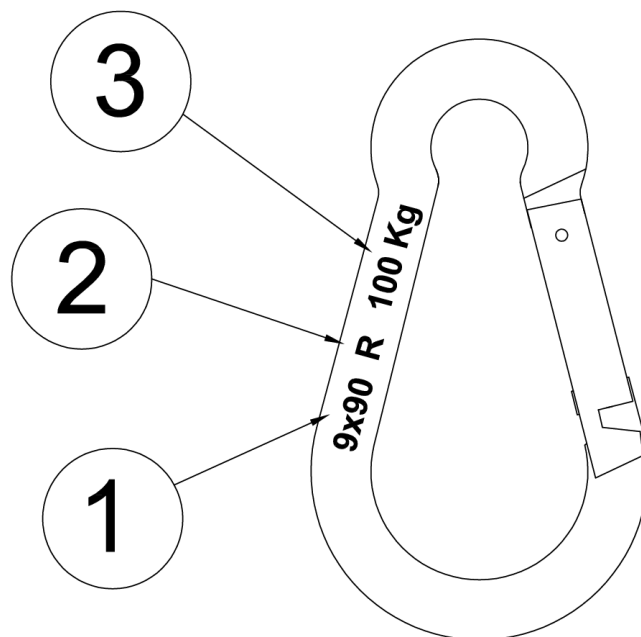

The positions of the markings in the drawings are given purely as an indication. The various items may actually be found in different positions.

4) GENERAL WARNINGS

The manual must be kept by the person in charge in a suitable place and readily available for consultation, in optimal conditions. Should it be lost or damaged, the manual can easily be retrieved on the constructor's web site: www.roburity.com the constructor retains all material and intellectual rights on the manual, and restricts its modification, albeit partial, for any commercial use.

As regards the information provided in these operating instructions, BETA UTENSILI S.P.A. will accept no responsibility in the event of:

- any use of the accessories other than the uses under national safety and accident prevention laws;
- mistaken choice or arrangement of the apparatus they are going to be connected to;
- failure to comply with, or properly follow, the operating instructions;
- changes to the accessories;
- misuse or failure to carry out routine maintenance jobs;
- use with noncompliant accessories.

!CAUTION: The marking data should not be removed by grinding or abrasion (whether accidental or not – any hooks that do not carry any identification references should be made unusable and scrapped).

No characters other than the manufacturer's may be affixed.

5) SELECTION CRITERIA

The following parameters should be carefully considered in choosing the hook:

5.A WORKING FORCE LIMIT

The tensile stress exerted on the hook **should be lower than or equal to** the working force limit (WFL) recommended for the item being considered, and shown in Table “A”.

5.B CONNECTING PART

Make sure that the connecting part suits the load capacity of the hook and has an adequate mechanical resistance to tensile forces.

5.C OPERATING TEMPERATURES

The maximum operating temperature is +80 °C.

For applications under 0 °C please use our carabine hooks, like items inoxn Robur 8274,8276 etc.

5.D LIFE AND FREQUENCY OF USE

The accessory is perfectly serviceable as long as its geometric and physical characteristics remain unchanged.

Hence the hook should be replaced in case of reduced section, deformation, corrosion or connecting instability.

6) NONPERMISSIBLE CONDITIONS

The hooks should not be operated under the following circumstances:

- when the applied force exceeds the permissible “WFL”;
- when dynamic stresses or swinging loads may result;
- when the hooks are operated under any temperatures and conditions other than the permissible temperatures;
- when the directrix of forces does not develop along the main axis.

7) PRELIMINARY TESTS

Before the accessories are operated and/or assembled, they should be tested by a suitably trained person.

- Check the state of the hook; in particular make sure that it is free from cuts, bends, indentations, abrasions, cracks, irregular threads, corrosions, sharp burrs, wear or defects resulting from improper storage.
- Measure and record the dimensions according to **Table “A”**.
- Check the state of all the parts of the marking, so that the accessory can be accurately identified according to the working force.

8) INSTALLATION – ASSEMBLY INSTRUCTIONS

During the installation of the accessory please use adequate Personal Protective Equipment: gloves, safety shoes, helmet, etc.

Fit the rope or the part to connect into the hook hole.

Insert one rope or one part for each hook.

Fit the system for hooking the part to connect into the hook seat, pushing the mouth locking system inwards; the mouth locking system will automatically be restored to the closing position after being fitted in, as the result of the spring force.

Do not allow the hooking point of the part to connect to be suspended between the hook tip and the mouth locking device, and check that it fits into the seat.

Make sure that, following connection, the mouth locking system is restored to the rest position.

While connecting, make sure that the hook can freely move and position itself; hence no forcing or interference should occur, to prevent any lateral force components from being produced.

Do not allow any forces to be released or any loads to be applied to the mouth locking system.

Tensile stress should be checked, to prevent the working force limit (WFL, see Table “A”) from being exceeded.

9) USING ACCESSORY – GRIP AND HANDLING

The hook is designed to be used in static situations; periodically check tensile stress and the state of preservation of the parts, according to the Table “Maintenance jobs and inspections”.

10) NONPERMISSIBLE USE

Using the accessory for any purposes other than the purposes it has been designed for, using it under extremely dangerous conditions and performing poor maintenance may pose **a severe hazard to the safety of the people being exposed** and cause severe damage to the working environment, while affecting the actual serviceability and safety of the product. The precautions mentioned below, which, obviously enough, cannot cover the whole spectrum of potential “**misuses**” of the accessory, should be “reasonably” deemed to be the most common steps to take. Therefore:

- DO NOT use the accessory for lifting purposes;
- DO NOT use the accessory for safety slings;
- DO NOT connect the accessory to any apparatus which does not match its specifications in terms of size, temperature, hook-up point and shape;
- DO NOT stretch any apparatus that may change its static configuration, centre of gravity or chemical and physical state;
- DO NOT use the accessory to lift or carry people or animals;
- DO NOT use the accessory to pull restrained loads;
- DO NOT work in areas where any explosion/spark-proof parts are expected to be used or in the presence of big magnetic fields;
- DO NOT weld any metal parts to the accessory; do not use any filling welds; do not use the accessory as mass for any welder.

11) FITNESS FOR USE

The accessory was subjected to spot check in order to test serviceability and performance at the manufacturer’s. However, before starting working, the user should test the installed accessory for serviceability and performance, to prove the entire system is fit for use.

12) INSPECTION AND MAINTENANCE

Inspections and maintenance jobs should be carried out by trained personnel, who should perform accurate tests during operation.

Below is a list of tests to perform at such intervals as stated in the table “**Maintenance jobs and inspections**”.

- **VISUAL TEST:** making sure that the accessory is free from surface defects, including cracks, indentations, cuts, fissures and abrasions.
- **DEFORMATION TEST:** making sure that the accessory has not got deformed, using a gauge to measure such critical dimensions as shown in **Table “A”**. **NO DEFORMATIONS** will be tolerated compared to the measurements made when the accessory was **first put into operation**.
- **WEAR TEST:** making sure that the points of contact are not worn, using a gauge to measure such critical dimensions as shown in **Table “A”**.
- **PRESERVATION TEST:** making sure that the accessory is free from oxidation and corrosion, especially in case of outdoor use; using suitable methods (e.g. liquid penetrants) to make sure that it is free from cracks.

The results of the above-mentioned tests should be stored.

Maintenance jobs and inspections			
Type of inspection			
	Whenever used	Month	Year
General visual inspection	X		
Deformation	X		
Wear		X	
State of preservation			X

If the hook has been used for heavy-duty jobs, both wear and the state of preservation should be tested for more frequently.

13) SCRAPPING ACCESSORY

The accessory should be scrapped by cutting, so that it can no longer be used, if:

- it is permanently worn compared to the original size;
- any cracks or distortions are shown, and/or the sections have become small compared to the original size.