

Owner's Manual & Assembly Instructions

Model No.

ED86

GD86-B

WR86

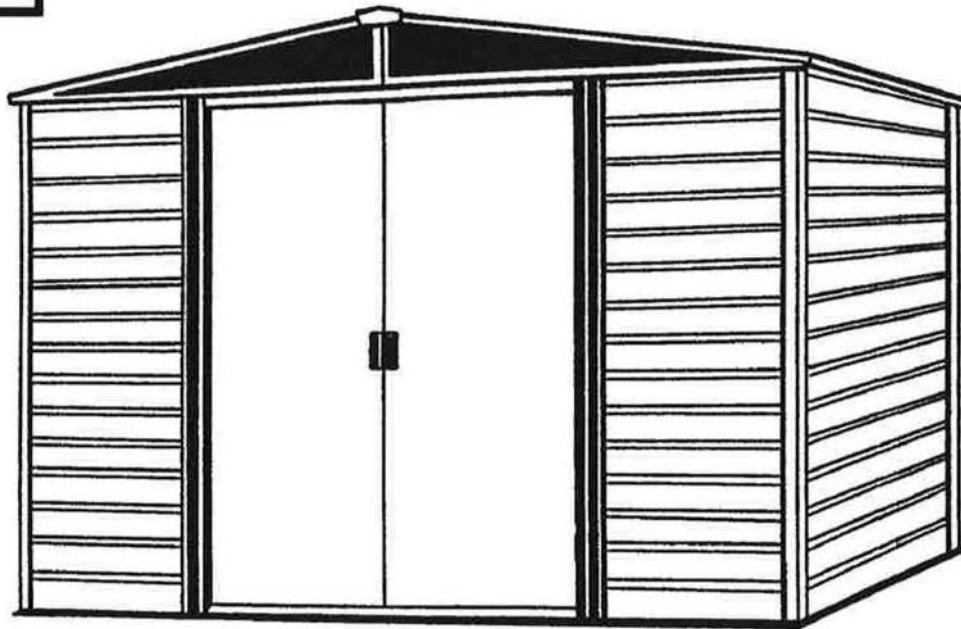

Storage Area: 43 Sq. Ft. 271 Cu. Ft.
4,0 m² 7,7 m³



CAUTION: SOME PARTS HAVE SHARP EDGES. CARE MUST BE TAKEN WHEN HANDLING THE VARIOUS PIECES TO AVOID A MISHAP. FOR SAFETY SAKE, PLEASE READ SAFETY INFORMATION PROVIDED IN THIS MANUAL BEFORE BEGINNING CONSTRUCTION. WEAR GLOVES WHEN HANDLING METAL PARTS.

BUILDING DIMENSIONS * Size rounded off to the nearest foot

*Approx. Size	Base Size	Exterior Dimensions (Roof Edge to Roof Edge)			Interior Dimensions (Wall to Wall)			Door Opening	
		Width	Depth	Height	Width	Depth	Height	Width	Height
8' x 6'	97 1/2" x 68 3/4"	99 3/4"	71 1/4"	79 1/8"	94 3/4"	66"	77 7/8"	43 1/2"	69 1/4"
2,4 m x 1,7 m	247,7 cm x 174,6 cm	253,4 cm	181,0 cm	201,0 cm	240,7 cm	167,6 cm	197,8 cm	110,5 cm	175,9 cm

BEFORE YOU BEGIN....

Owner's Manual

Before beginning construction, check local building codes regarding footings, location and other requirements. Study and understand this owner's manual.

Important information and helpful tips will make your construction easier and more enjoyable.

Assembly Instructions: Instructions are supplied in this manual and contain all appropriate information for your building model. Review all instructions before you begin, and during assembly, follow the step sequence carefully for successful results.

Flooring and Anchoring: Your [storage building](#) must be anchored to prevent wind damage. A base is necessary to construct a square and level building. Anchoring and base materials are not included with your building. We recommend the combined use of an **Arrow Floor Frame Kit** and an **Arrow Anchoring Kit** as an effective method of securing your building to the ground.

Parts and Parts List: Check to be sure that you have all the necessary parts for your building.

- All part numbers can be found on the parts. All of these numbers (before the -) must agree with the numbers on the Parts List page.

- Separate contents of the carton by the part number while reviewing parts list. The first few steps show how to join related parts to make larger sub assemblies which will be used later.

- Familiarize yourself with the hardware and fasteners for easier use during construction. These are packaged within the carton. Note that extra fasteners have been supplied for your convenience.

PLAN AHEAD....

Watch the Weather: Be sure the day you select to install your building is dry and calm. Do not attempt to assemble your building on a windy day. Be careful on wet or muddy ground.

Teamwork: Whenever possible, two or more people should work together to assemble your building. One person can position parts or panels while the other is able to handle the fasteners and the tools.

Tools and Materials: These are some basic tools and materials you will need for the construction of your building. Decide which method of anchoring and the type of base you wish to use in order to form a complete list of the materials you will need.

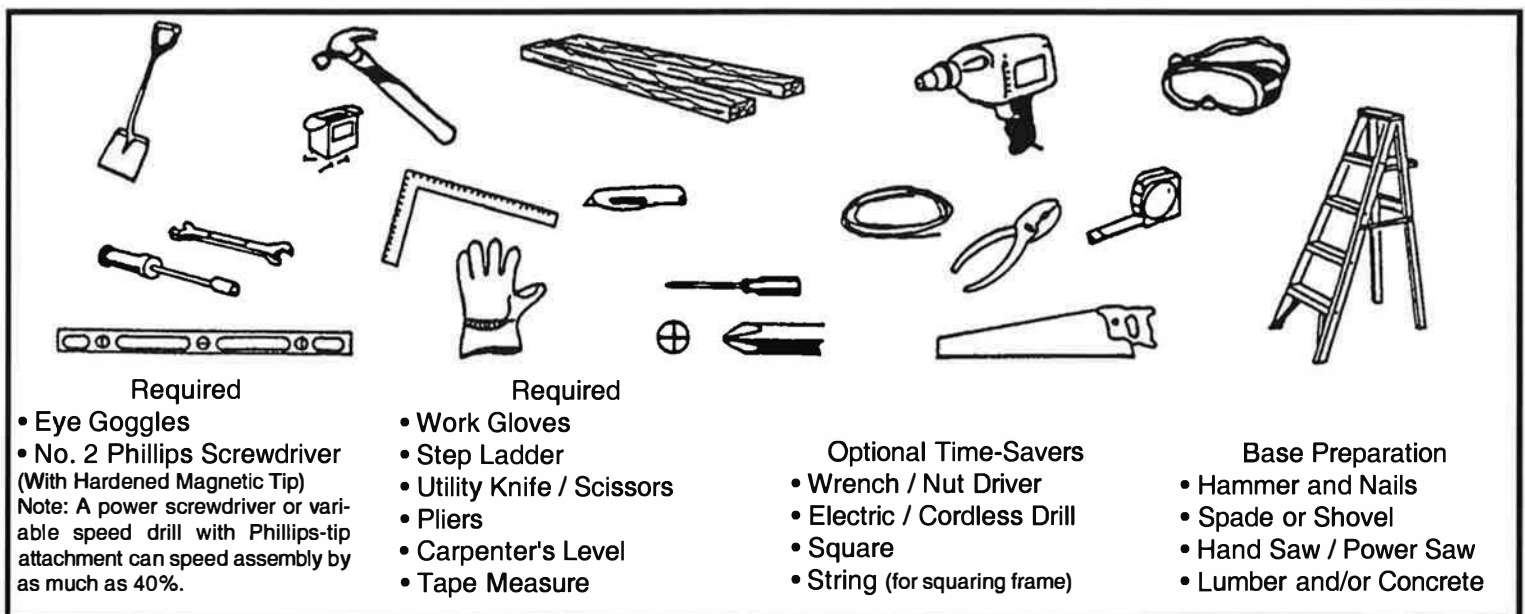

Selecting and Preparing Your Site: Before assembly, you will want to decide on a location for your building. The best location is a level area with good drainage.

- Allow enough working space for ease of moving parts into position during assembly. Be sure there will be enough space at entrance for doors to open fully and enough space around the building to be able to fasten the panel screws from the outside.

- Before you begin the first steps in assembling your parts, a base should be constructed and an anchoring system should be ready to use.

SAFETY FIRST...

Safety precautions are important to follow throughout the construction of your building.

•Care must be taken when handling various pieces of your building since some contain sharp edges. Please wear work gloves, eye protection and long sleeves when assembling or performing any maintenance on your building.

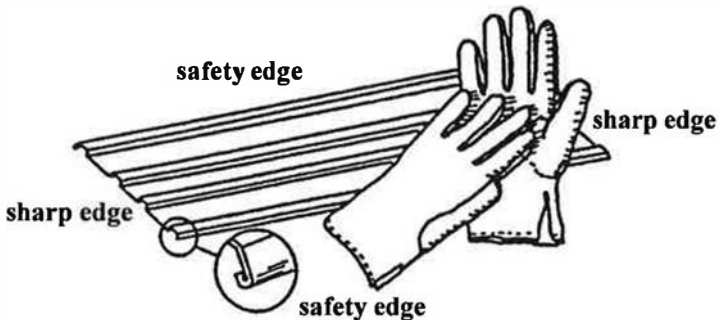

•Keep children and pets away from worksite to avoid distractions and any accidents which may occur.



•Never concentrate your total weight on the roof of the building. When using a step ladder make sure that it is fully open and on even ground before climbing on it.

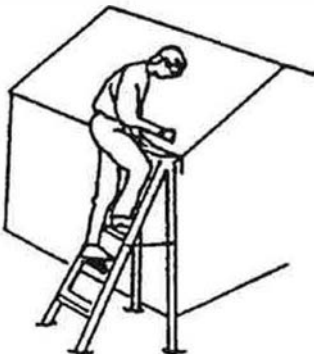

•Practice caution with the tools being used in the assembly of this building. Be familiar with the operation of all power tools.

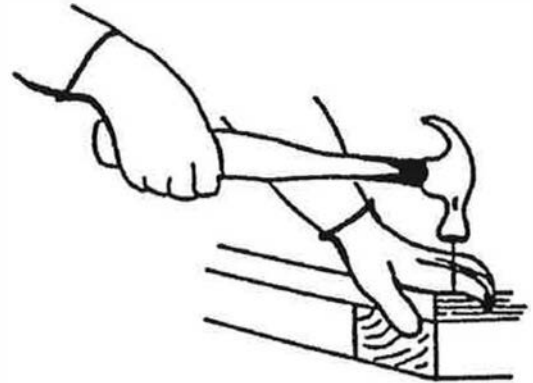

•Do not attempt to assemble the building if parts are missing because any building left partially assembled may be seriously damaged by light winds.

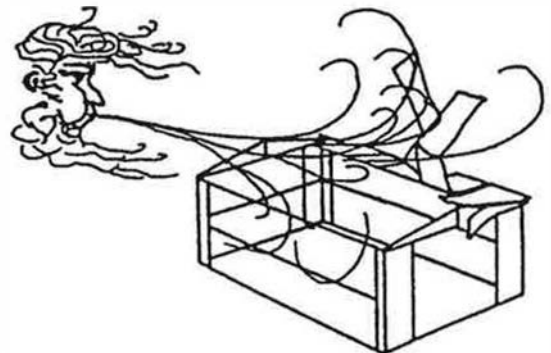

•Do not attempt to assemble the building on a windy day, because the large panels acting as a "sail", can be whipped about by the wind making construction difficult and unsafe.



CARE & MAINTENANCE....

Finish: For long lasting finish, periodically clean and wax the exterior surface. Touch-up scratches as soon as you notice them on your unit. Immediately clean the area with a wire brush; wash it and apply touch-up paint per manufacturer's recommendation.

Roof: Keep roof clear of leaves and snow with long handled, soft-bristled broom. Heavy amounts of snow on roof can damage building making it unsafe to enter. In snow country, Roof Strengthening Kits are available for most Arrow Buildings for added protection against heavy snow accumulation.

Doors: Always keep the door tracks clear of dirt and other debris that prevent them from sliding easily. Lubricate door track annually with furniture polish or silicone spray. Keep doors closed and locked to prevent wind damage.

Fasteners: Use all washers supplied to protect against weather infiltration and to protect the metal from being scratched by screws. Regularly check your building for loose screws, bolts, nuts, etc. and retighten them as necessary.

Moisture: A plastic sheet (vapor barrier) placed under the entire floor area with good ventilation will reduce condensation.

Other Tips....

- Wash off inked part numbers on coated panels with soap and water.
- Silicone caulking may be used for watertight seals throughout the building.

Do not store swimming pool chemicals in your building. Combustibles and corrosives must be stored in air tight approved containers.

Keep this Owner's Manual and Assembly Instructions for future reference.

ACCESSORIES...

ROOF STRENGTHENING (heavy snow load) KITS

Extra roof beams and gable braces designed for added protection against heavy snow accumulation. Increases the strength of your roof by 50%.

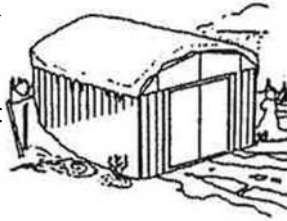

ANCHOR KITS

Model No. AK4

Anchor Kit contains heavy-duty steel augers, 60' (18 m) of steel cable and 4 cable clamps. No digging or concrete pouring, just insert cable under roof, over roof beams, into augers and twist augers into the ground. For buildings larger than 10'x9' (3,0 m x 2,6 m), use 2 kits.

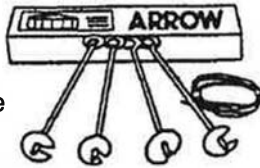

Model No. AK100

New concrete anchor system permits anchoring any size Arrow building directly to a concrete slab. Each kit contains heavy-duty, hot-dipped galvanized steel corner gussets and perimeter clips which fit over the floor frame and lag bolt into a concrete slab. Full assembly instructions and a 1/4" masonry drill bit are included.

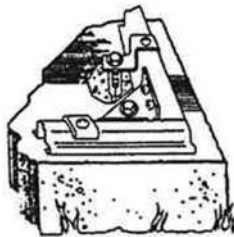

Model No. AK600

Earth Anchor Kit anchors any size Arrow building to the ground. Each kit contains heavy duty, hot-dipped galvanized steel corner gussets and 4 earth anchors.

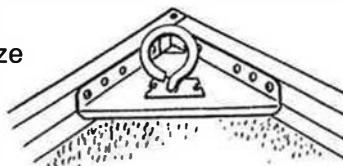

TOOL HANGING RACK

Model No. TH100

The perfect tool organizer. Twin 25 1/2" (64,8 cm) steel channels plus five heavy-duty snap-in hangers and a small tool holder for screwdrivers, pliers, etc. Holders slide along channel for fully adjustable spacing. Great for garage, basement, or the back of any door. Fits all Arrow storage buildings.

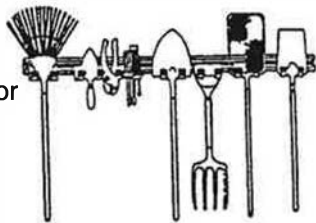

FLOOR FRAME KITS



MODELS FB47410, FB5465, FB106-A
FB109-A and FB1014-A

A simple new floor frame system made of heavy-duty, hot-dipped galvanized steel. Use as base for plywood, sand or stone.

ATTIC KIT / WORKBENCH KIT

Model No. AT101

Heavy-duty galvanized steel bars that fit all 10' (3,0 m) wide Arrow buildings. They install quickly and easily to help organize space and create more useable space as an attic or workbench. Will hold up to 250 lbs. (113 kg) evenly distributed.



Some drilling required to fit buildings without mid-wall bracing.

SHELF UNITS

Heavy-duty, galvanized steel shelf units help organize storage space. They easily mount on the wall or sit on the floor. Fits all Arrow buildings.*

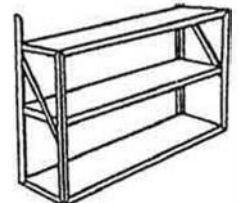
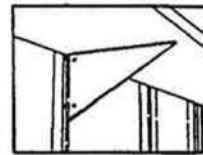
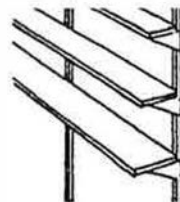

Model No. SS404

- Makes 8" to 12" (20,3-30,5 cm) wide shelves in any length.
- Brackets, braces, hardware included. Lumber is not included.

Model No. SS900-B

- Grey color
- 3 shelves
- Holds up to 85 lbs. (38 kg) (even weight distribution)

* Some drilling required to fit buildings without mid-wall bracing.

Base

The Base For Your Building

No matter which of the options below you choose for a base, an ARROW ANCHORING KIT is recommended as an effective method of properly securing your building after assembly is complete.

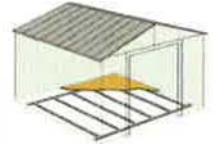

OPTION 1: Directly on ground (earth)

Assemble your building directly on level ground (grass, dirt, rock, sand, etc.). If you choose this option Arrow has a simple kit available to provide a floor **inside** the shed to keep stored items off the ground. This kit can be used to support a plywood floor (wood not included) or be filled with sand/rock to provide a solid surface. (Order No. FB106-A or 68381-A)

Allow 1 - 2 hours for construction.

OPTION 2: Wood Platform

If you decide to build your own base, be sure to select the appropriate materials.

These are the recommended materials for your base:

- 2 x 4's (38 mm x 89 mm) Pressure Treated Lumber
- 5/8" (15,5 mm) 4 x 8 (1220 mm x 2440 mm) Plywood-exterior grade **NOTE:** Pressure Treated Lumber must not be used where it will make contact with your storage building. The properties of Pressure Treated Lumber will cause accelerated corrosion.

If Pressure Treated Lumber comes in contact with your storage building your warranty will be voided.

- 10 & 4 penny Galvanized Nails ● Concrete Blocks (optional)

The platform should be level and flat (free of bumps, ridges etc.) to provide good support for the building. The necessary materials may be obtained from your local lumber yard.

To construct the base follow instructions and diagram.

- Construct frame (using 10 penny galvanized nails)
- Measure 16"/24" (40,6 cm/61,0 cm) sections to construct inside frame (see diagram)
- Secure plywood to frame (using 4 penny galvanized nails)

Allow 6 - 7 hours for construction.

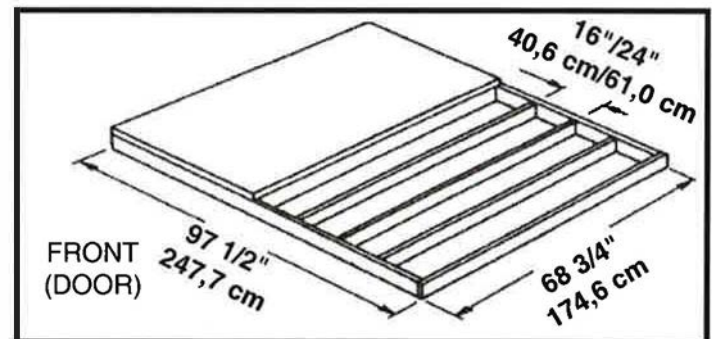

Note: Platform/Slab will extend 9/16" (1,4 cm) beyond floor frame on all four sides. Seal this 9/16" (1,4 cm) of wood with a roofing cement (not included), or bevel this 9/16" (1,4 cm) of concrete when pouring, for good water drainage.

OPTION 3: Concrete Slab

The slab should be at least 4" (10,2 cm) thick. It must be level and flat to provide good support for the frame.

The following are the recommended materials for your base.

- 1 x 4's (19 mm x 89 mm) (will be removed once the concrete cures)
- Concrete ● Sheet of 6 mil plastic
- We recommend for a proper strength concrete to use a mix of:
1 part cement ● 3 parts pea sized gravel ● 2 1/2 parts clean sand

Prepare the Site/Construct a Base

1. Dig a square, 6" (15,2 cm) deep into the ground (remove grass).
2. Fill up to 4" (10,2 cm) in the square with gravel and tamp firm.
3. Cover gravel with a sheet of 6 mil plastic.
4. Construct a wood frame using four planks of 1x4 (19 mm x 89 mm) lumber.
5. Pour in concrete to fill in the hole and the frame giving a total of 4" (10,2 cm) thick concrete. Be sure surface is level.

Allow 3 - 5 hours for construction and a week for concrete curing time.

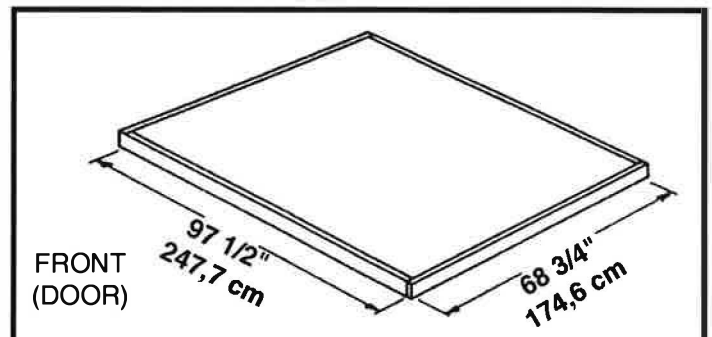

Note: Finished Slab dimensions, with lumber removed.

Anchoring

Anchoring Down The Building

It is important that the entire floor frame be anchored after the building is erected.

Below are recommended ways of anchoring.

Arrow Anchoring Kit: (Model No. AK4 or 60298)

Recommended for use with **any** suggested **base**.

Contains: 4 Anchors with Cable, Clamps and installation instruction.

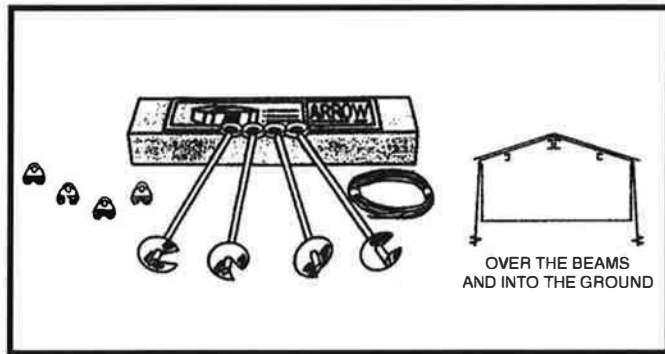

Anchoring into Wood/Post:

Use 1/4" (6 mm) Wood Screws. There are 1/4" (6 mm) dia. holes provided in the frames for proper anchoring.

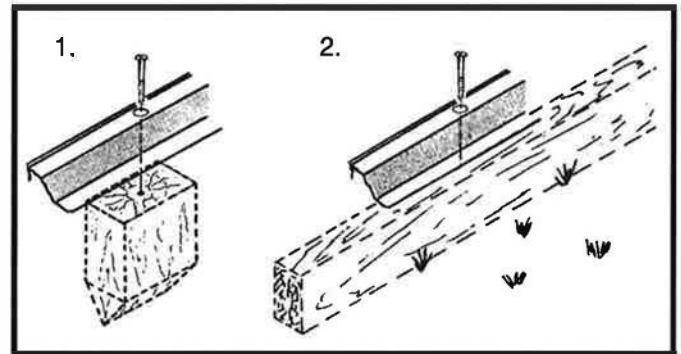

Arrow Anchoring Kit: (Model No. AK100 or 68383)

Recommended for use with the **concrete** base.

Contains: Corner gussets, perimeter clips, hardware, 1/4" masonry drill bit and installation instruction.

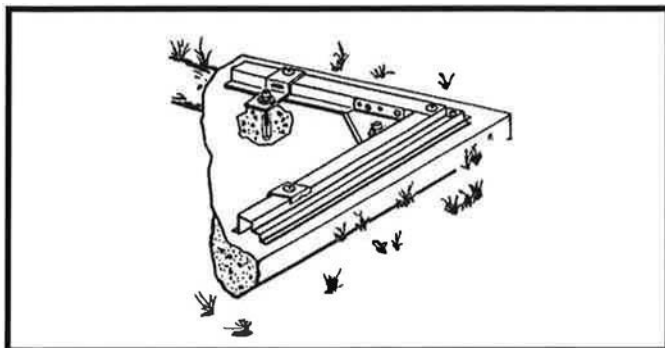

Anchoring into Concrete:

1. For poured concrete slab or footing or patio blocks: Use 1/4" x 2" (6 mm x 51 mm) Lag Screws.
2. For Anchor Post of Concrete poured after building is erected: Use 1/4" x 6" (6 mm x 152 mm) Lag Screws.

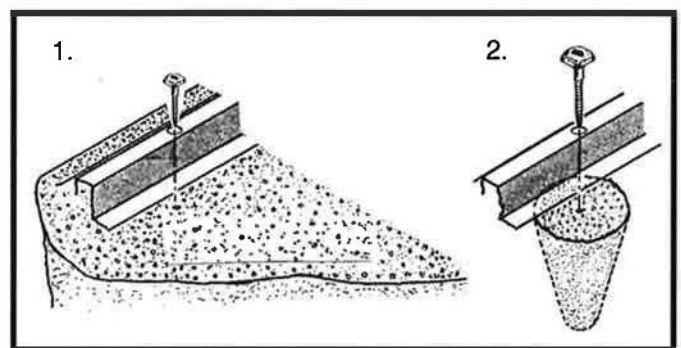

Hardware

Remove from bag of screws
and save for the last step



65103
#8-32 Hex Nut (93)



65900A
#10Bx1/2" (13 mm)
Black Screw (8)
(Packed with Screws)



65923
#8-32x3/8" (10 mm)
Bolt (93)



65004
#8Ax5/16" (8 mm)
Screw (282)

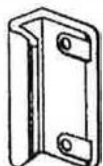

66045
Handle (2)

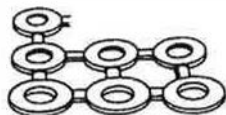

66646
Washer (176)
(5 sheets of 40)



65109
#8-32 Acorn Nut (2)
(Packed with Screws)



67293
Weather Stripping (1)

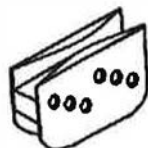

66769
Door Slide (4)

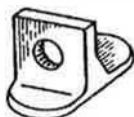

66382
Lower Door Guide (4)

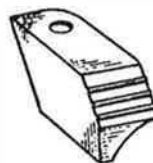

66183
Roof Trim Cap
(2 right & 2 left)



67468
Peak Cap (2)

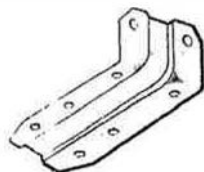

6228
Track Support (2)

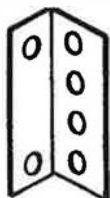

7916
Roof Beam Bracket (4)

Parts List

Assembly Key No.	Part Number	Part Description	Quantity in Carton	Check List
1	8941	Ramp	1	
2	9379	Front Floor Frame	2	
3	9377	Rear Floor Frame	2	
4	9336	Right Rear Wall Angle	1	
5	9378	Door Track	2	
6	6617	Door Track Splice	1	
7	9337	Left Rear Wall Angle	1	
8	7907	Left Gable	2	
9	7906	Right Gable	2	
10	8946	Side Floor Frame	2	
11	5288	Corner Post	4	
12	9342	Side Wall Angle	2	
13	5287	Splice Post	1	
14	7311	Door Jamb	2	
15	9344	Siding Stud	6	
16	8719	Side Siding	6	
17	6658	Gable Brace	2	
18	9345	Rear Siding	6	
19	9746	Front Siding	6	
20	8474	Roof Beam	3	
21	8476	Side Wall Angle	1	
22	8466	Right Roof Panel	2	
23	7875	Roof Panel	4	
24	8467	Left Roof Panel	2	
25	8461	Ridge Cap	1	
26	8482	Side Roof Trim	2	
27	10484	Right Door	1	
28	10484	Left Door	1	
29	10498	Horizontal Door Brace	4	
30	6301	Vertical Door Brace	2	

Assembly by Key No.

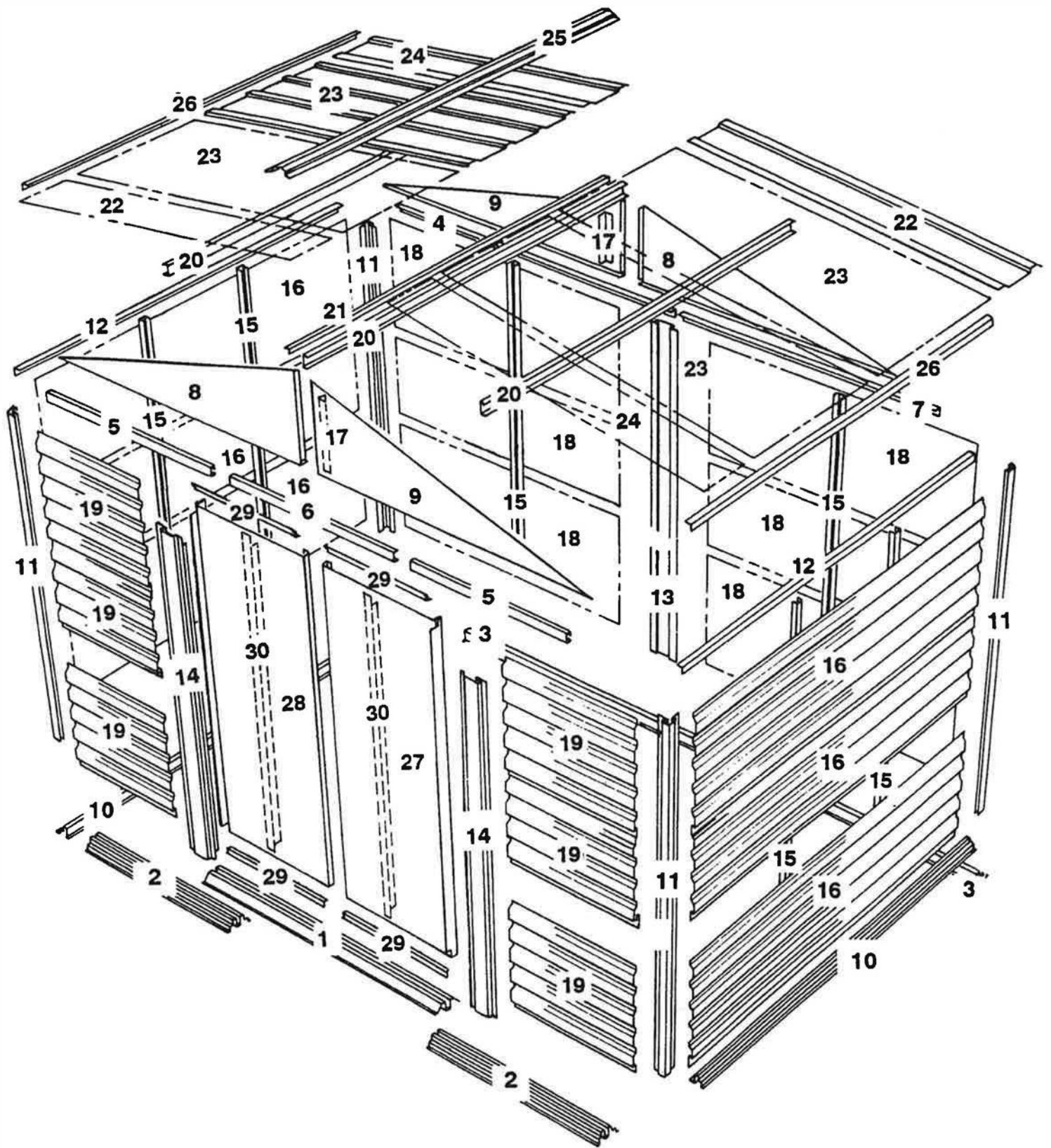

Step 1

● Parts Needed For ● Floor Frame Assemblies

- 8941 Ramp (1)
- 9379 Front Floor Frame (2)
- 9377 Rear Floor Frame (2)

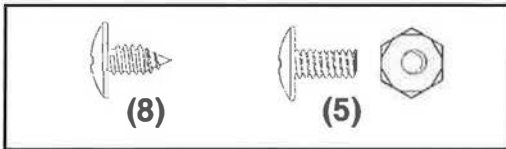

The front floor frame is made up of three pieces. The rear floor frame is made up of two pieces. The holes in these pieces will align when the pieces are positioned with correct amount of overlap. The illustrations below show the proper overall length for the front and rear. Proceed as follows:

1 Place the **front floor frames** as shown. Center the **ramp**, with drain holes facing outside, on top of the two front floor frames. Join the frames by inserting eight screws.

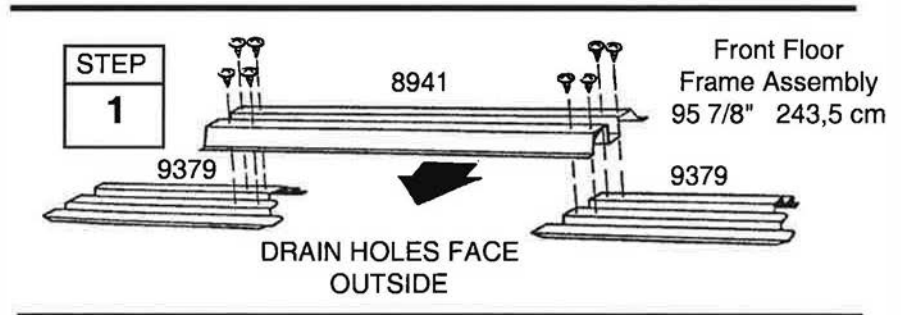
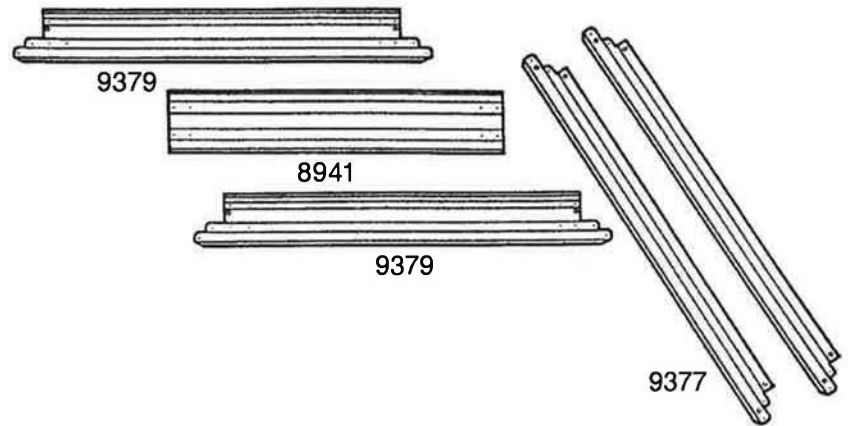

2 Overlap the **rear floor frames** as shown. The holes in these pieces will align when the pieces are positioned with correct amount of overlap. See the illustrations below for the proper overall length of the rear floor frame. Join the frames by inserting five bolts into frame set as shown.

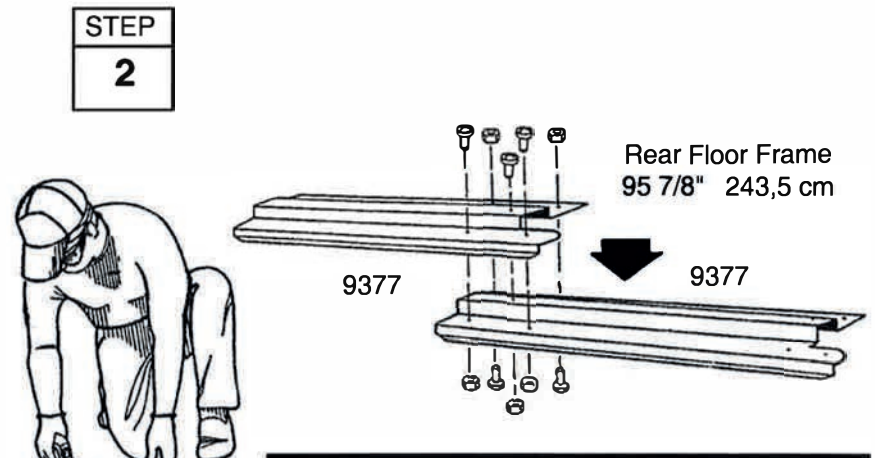

3 Double check the length of each and set these pieces aside for later use.

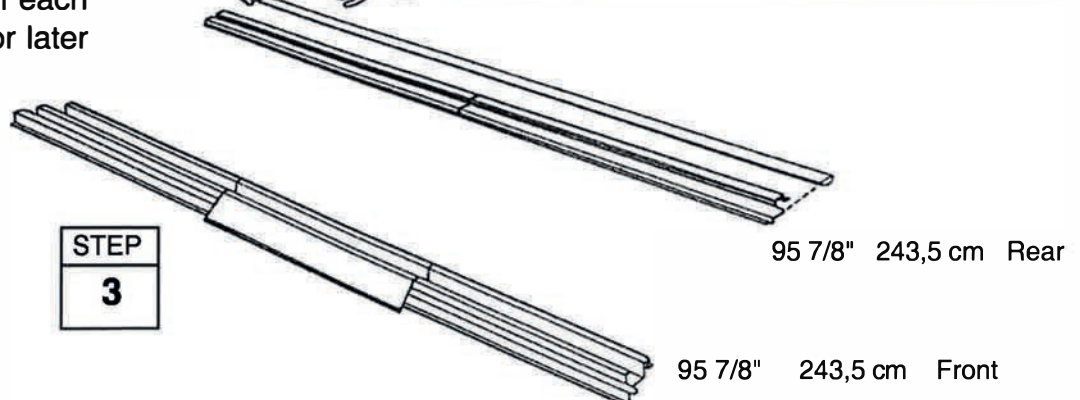

Step 2

● Parts Needed For ● Frame Assembly

- 9336 Right Rear Wall Angle (1)
- 9337 Left Rear Wall Angle (1)

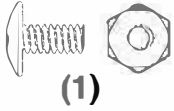

The main frame pieces reinforce the walls. This piece will later be installed at the top edge of the rear wall. Proceed as follows:

1 Overlap the **right** and **left rear wall angle** pieces as shown in the figure and fasten them together with *one bolt in the center hole*.

2 Set the assembly aside. You will use it later.

STEP
1

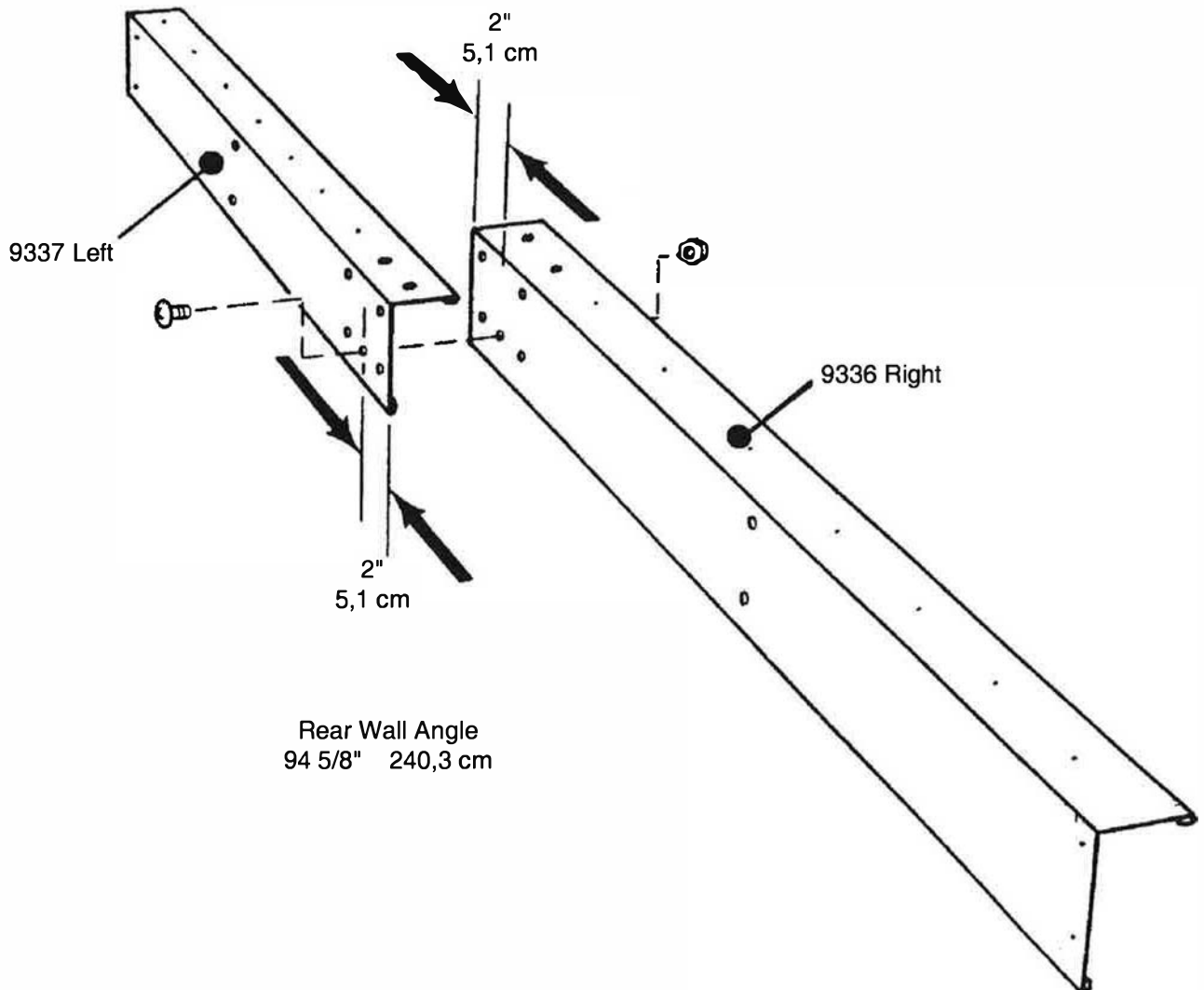

Step 3

● Parts Needed For ● Roof Beam Assembly

- 8474 Roof Beam (1)
- 8476 Side Wall Angle (1)

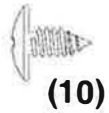

The roof beams join the two gables and support the roof panels. The main roof beam is made up of two pieces fastened together.

1 Place the **side wall angle**, back-to-back, with a **roof beam** and fasten together using ten screws.

2 Set this piece aside for later use.

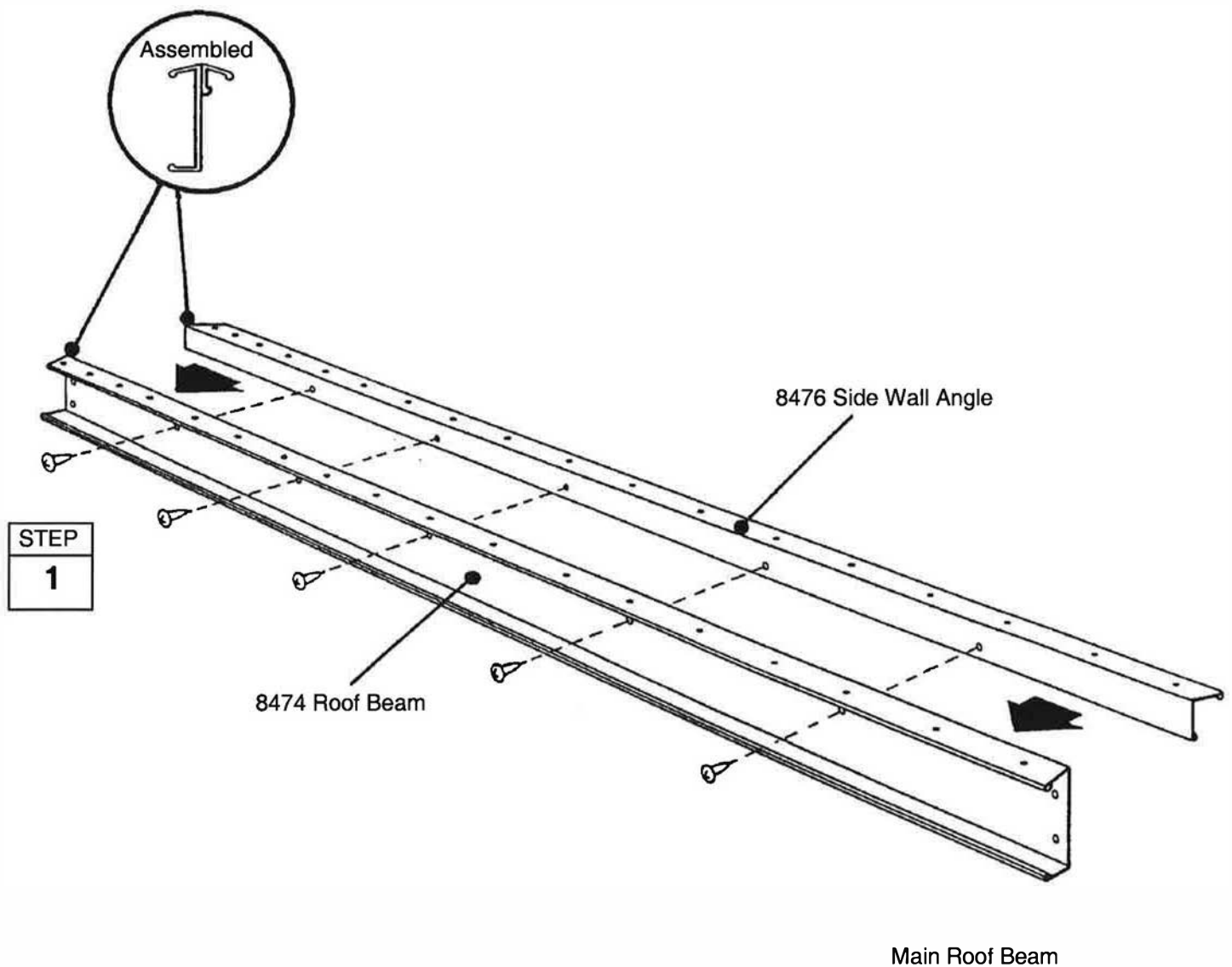

Step 4

● Parts Needed For ● Door Track Assembly

- 6617 Door Track Splice (1)
- 9378 Door Track (2)

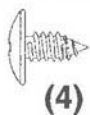

The door track assembly supports the sliding doors and reinforces the front wall. It is made up of three pieces.

1 Using the **door track splice**, (painted), join the **door track** (galvanized) pieces end-to-end as shown.

2 Insert four screws *from the underside only*.

Hint: The holes in the top side of the door track assembly are for fastening the gable to the top of the front wall in a later step.

3 Position **door slides** onto the legs, from the end of door track assembly, as shown in the end view.

4 Set this piece aside for later use.

NOTE:
Door Track Splice (painted part)

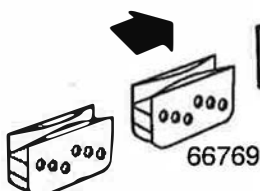
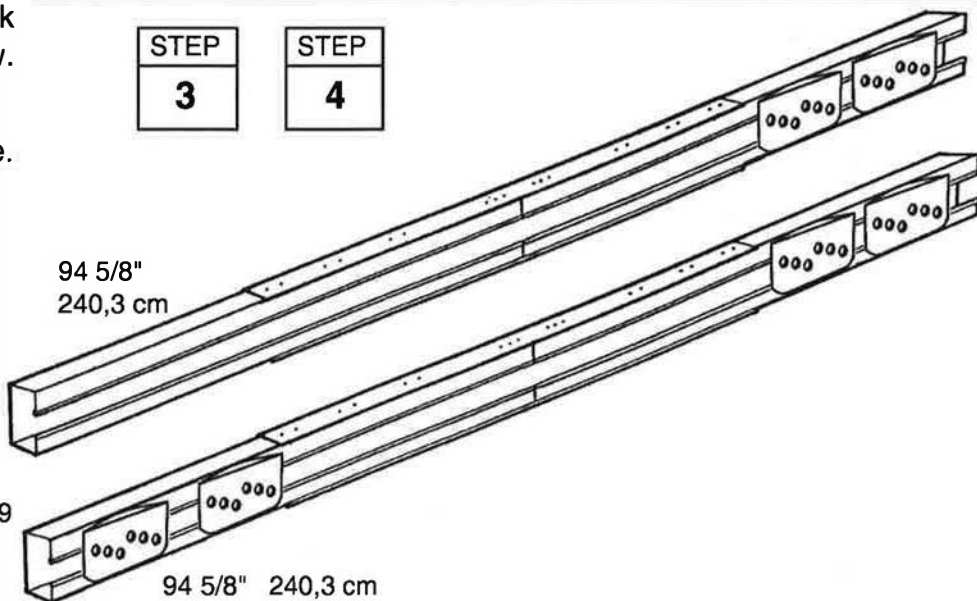
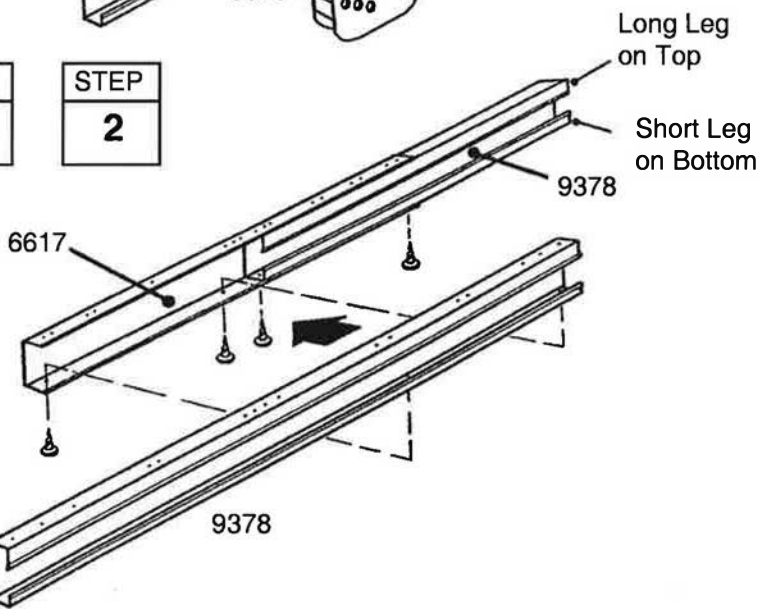
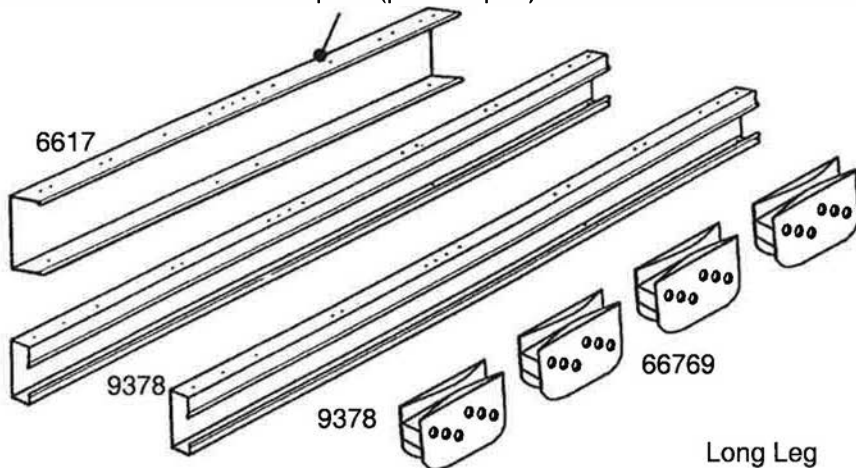

Step 5

● Parts Needed For ● Floor Frame

- Front Floor Assembly (1)
- 8946 Side Floor Frame (2)
- Rear Floor Assembly (1)

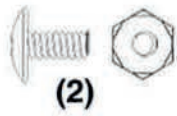
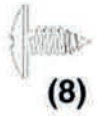

1 Assemble the four corners of the floor frame using two screws at each corner as shown. At the front corners fasten bolts through from the bottom with nuts on top.

2 Measure the floor frame diagonally. When the diagonal measurements are equal, the floor frame is square.

STEP
1

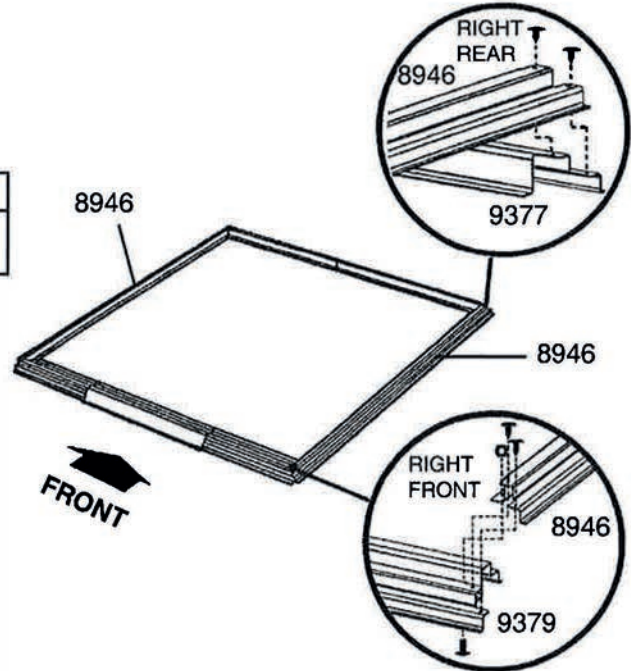

NOTE

If using a wood platform or concrete slab do not fasten the floor frames to your base at this time. You will anchor the building after it is erected.

When Diagonal Measurements are Equal the Floor Frame is Square.

STEP
2

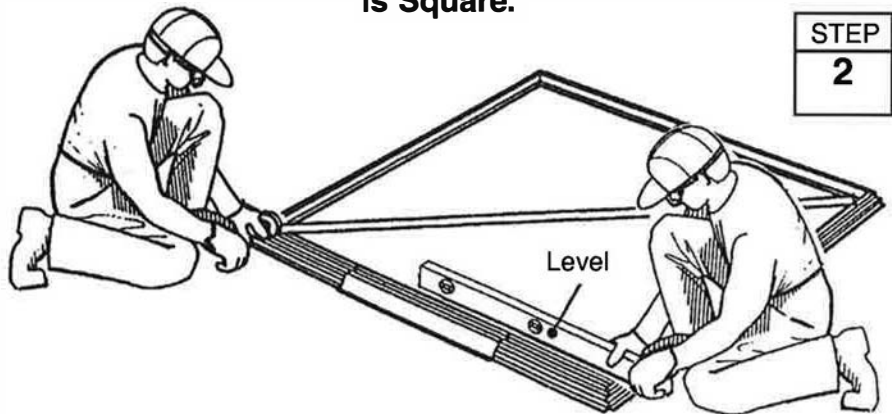

The floor frame *must be square and level* or holes will not align.

Step 6

● Parts Needed For ● Posts/Top Frames

- 5288 Corner Post (4)
- Door Track Assembly (1)
- Rear Wall Angle Assembly (1)
- 9342 Side Wall Angle (2)



NOTE

The remainder of the building assembly requires many hours and more than one person. Do not continue beyond this point if you do not have enough time to complete the assembly today. A partially assembled building can be severely damaged by light winds.

The top frame pieces give rigidity to the side walls and provide a surface for attaching the gables which support the roof.

1 Position **corner posts** at the corner of the floor frame as shown. Fasten the corner post to the floor frame with two screws.

Support the corner posts with stakes or other devices until door jambs are attached.

2 Fasten the **door track assembly** (holes on top) behind the top of the front corner posts using 1 screw in each corner. See the figure.

3 Fasten the **rear wall angle assembly** behind the top of the rear posts using 2 screws in each post.

4 Fasten the **side wall angles** behind the top of the side posts using 2 screws in each corner. Side wall angles overlap rear wall angle in corners.

The floor frame must be square and level or holes will not align.

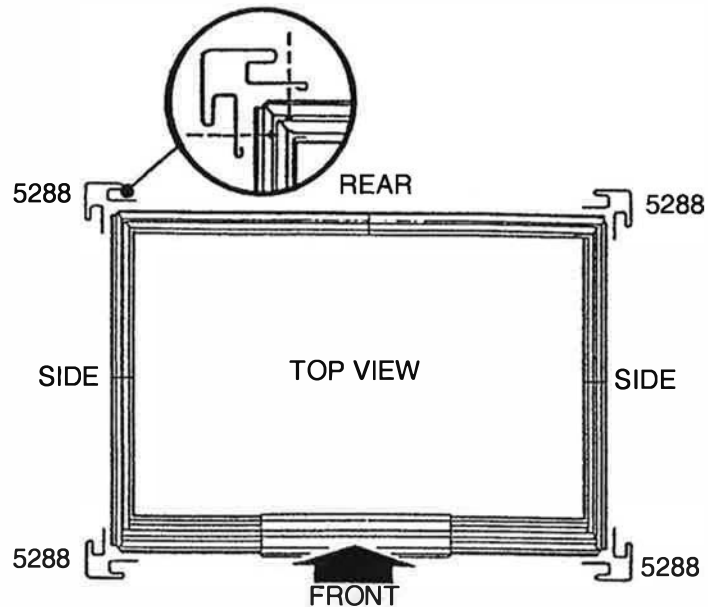

STEP
1

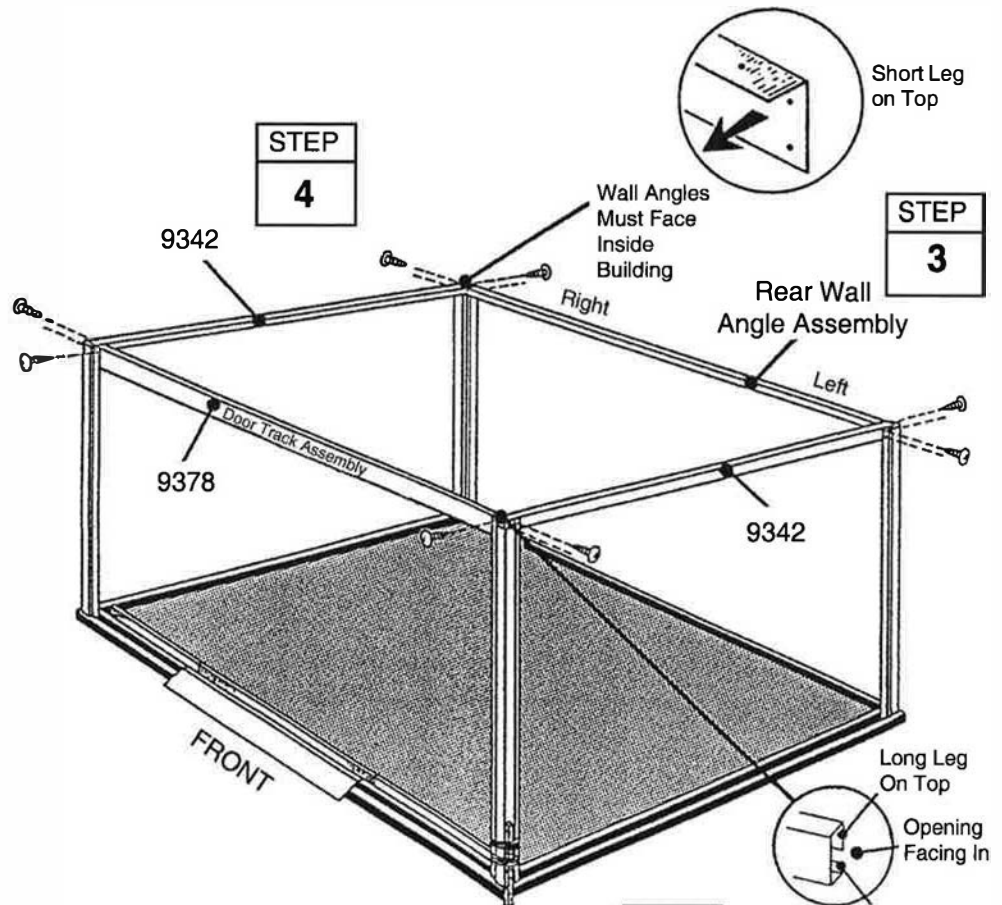

STEP
4

STEP
3

STEP
2

Short Leg
on Top

Wall Angles
Must Face
Inside
Building

Rear Wall
Angle Assembly

Right

Left

9342

9378

9342

FRONT

Long Leg
On Top

Opening
Facing In

Short Leg
on Bottom

Step 7

● Parts Needed For ● Splice Post/Door Jamb

- 5287 Splice Post (1)
- 7311 Door Jamb (2)

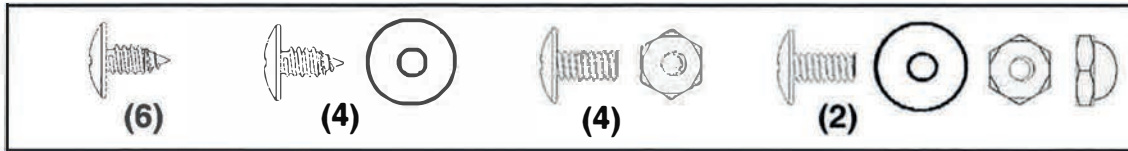

STEP
1

The door jambs reinforce the door opening and provide an attractive trim. The splice post supports the rear wall.

1 Position **splice post** at the center of the rear wall and fasten using 4 bolts and nuts into rear wall angle and 2 screws into rear floor frame.

Hint: Measure or count holes to determine if post is centered on rear.

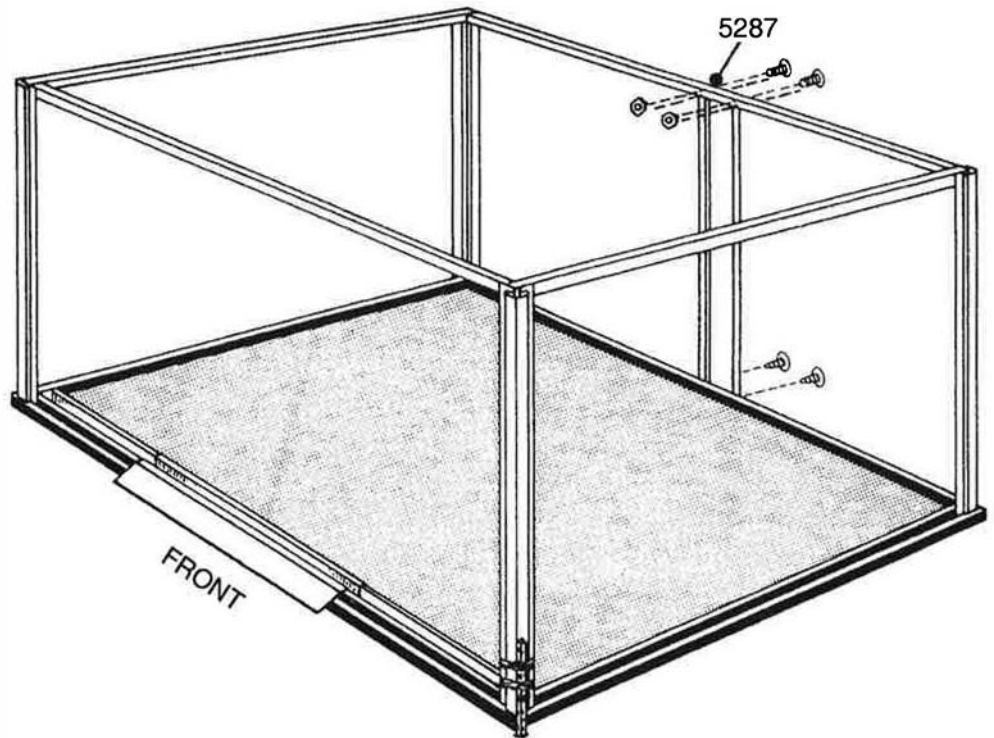

2 Fasten the top of the **door jambs** to the door track with two screws. Do the same for the bottom into frame. There must be a 7/8" (2,2 cm) gap between end of ramp and edge of door jamb. Notched edge faces toward center of building. Fasten middle hole on inside edge of door jamb with a bolt inside building and a hex nut with an acorn nut outside, as shown.

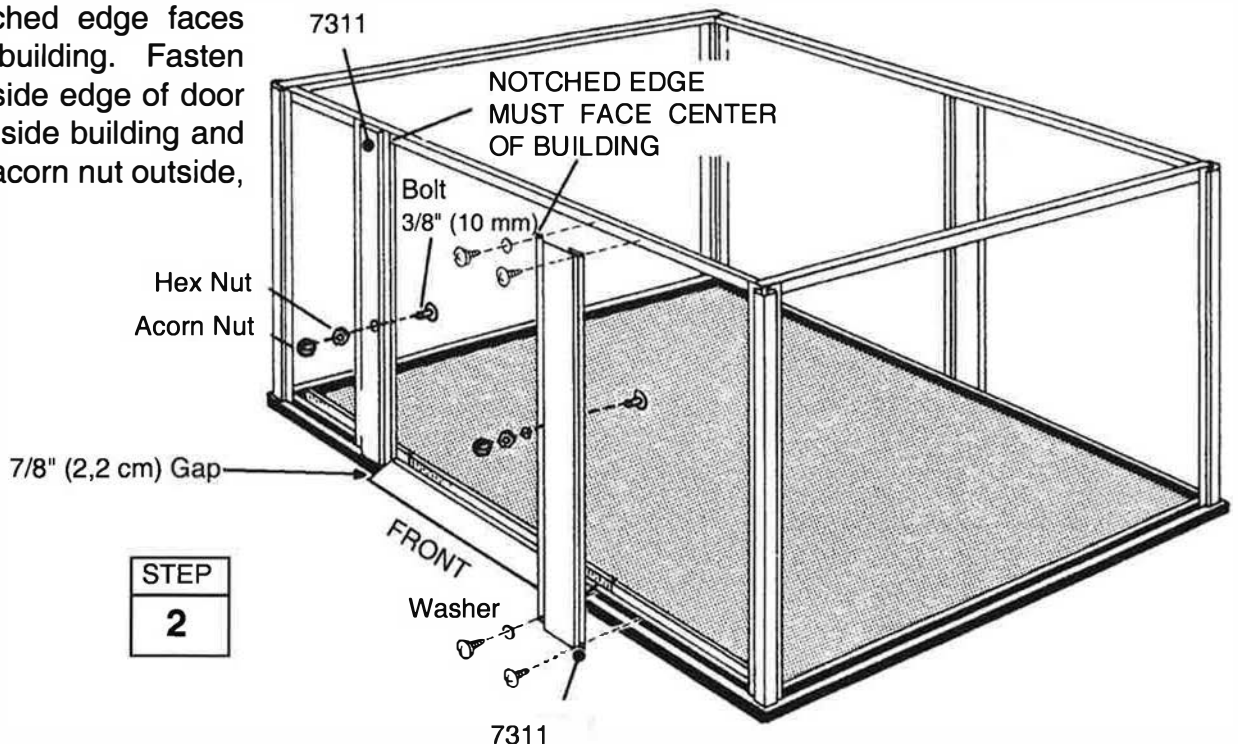

STEP
2

Step 8

● Parts Needed For ● Studs

● 9344 Siding Stud (6)

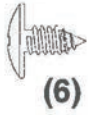

The studs provide a surface for attaching the siding panels.

1 Following dimensions, measuring from the ends of angles, place a **stud** between each corner and splice post at the rear of building and 2 **studs** between corner posts at the sides. Position stud inside top angle and fasten with a screw at the lower hole.

2 Rest bottom tab (large hole) outside floor frame. Do not fasten tab at this time. Repeat procedure for the remaining studs around the building.

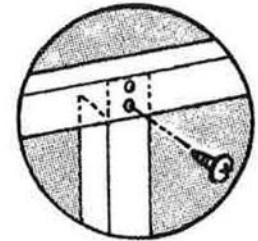

FASTEN STUD AT
LOWER HOLE

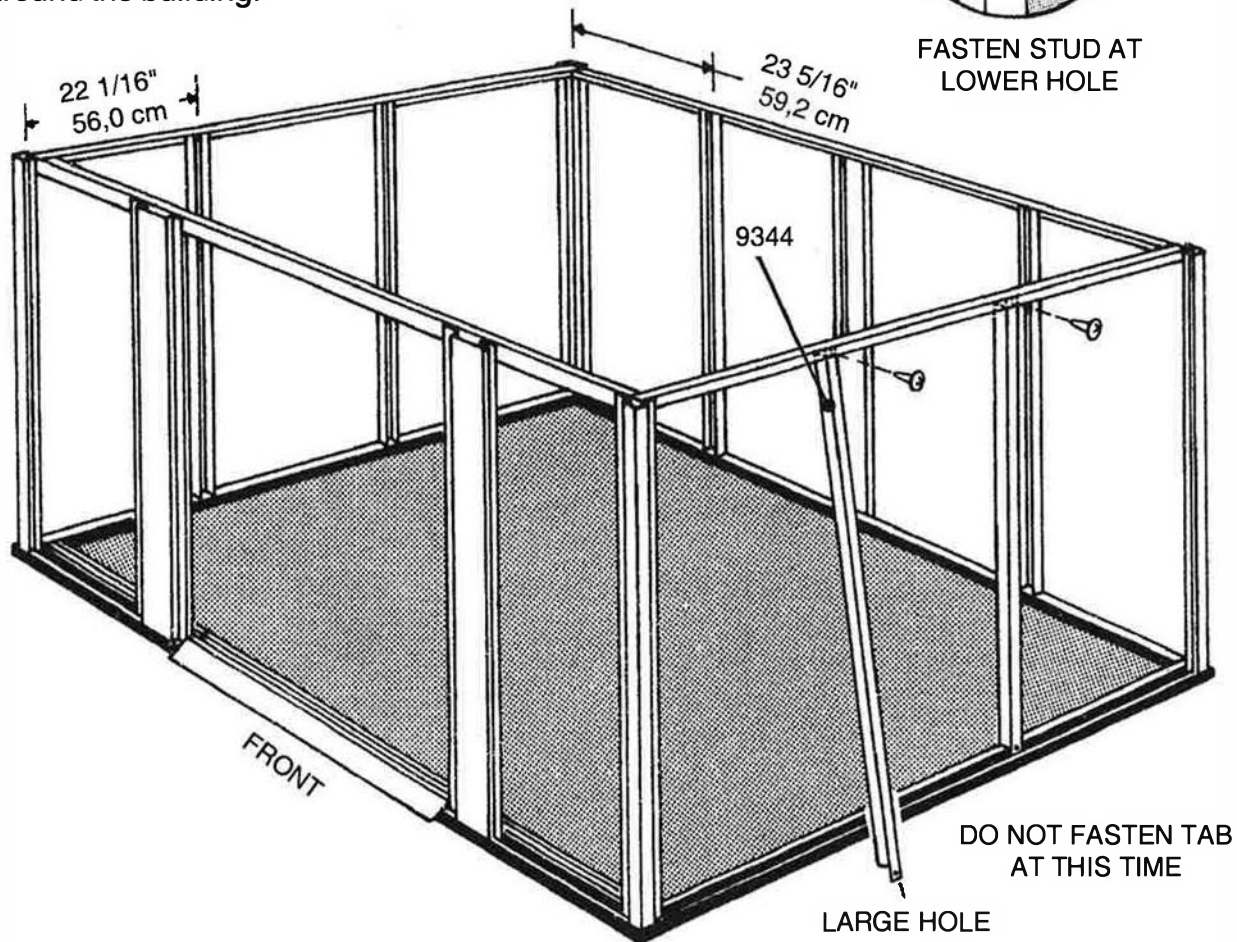

Step 9

● Parts Needed For ● Side Siding

● 8719 Side Siding (6)

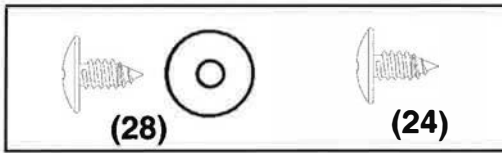

Each screw in the wall requires a washer.



CORRECT



INCORRECT

1 Slide **side siding** into channels of corner posts, flat edge upward, bottom edge down resting on floor frame. Always follow this pattern. Fasten bottom edge and tab of stud to floor frame using screws. Fasten center to stud with screws. Do not fasten flat edge yet.

2 Install **side siding** as before. Note how the slot in bottom edge must overlap flat edge of last siding. Fasten both siding panels to stud at this overlap.

3 Install **side siding** to the top as before.

4 From inside building, fasten siding to corner posts using screws.

5 Repeat steps 1 through 4 for opposite side of building.

NOTE

Be careful to install the correct panel in each position as shown.

The floor frame must be square and level or holes will not align.



STEP
4

STEP
3

STEP
2

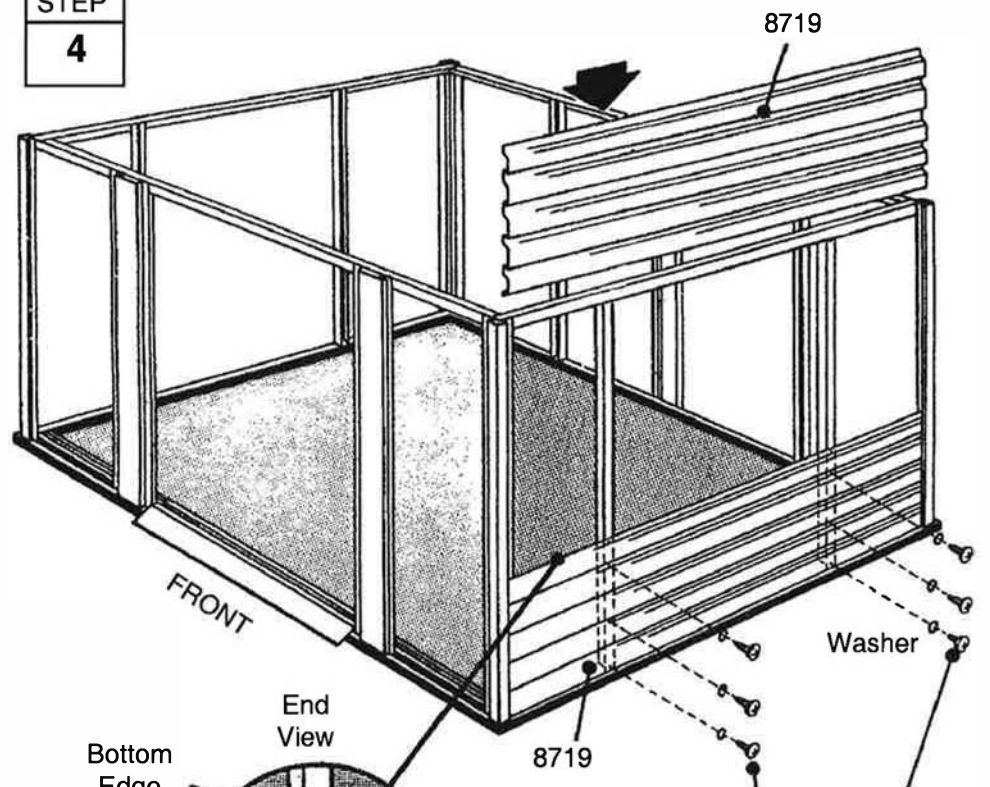

Bottom Edge

End View

Flat Edge

Be certain all Siding overlaps are fastened with a single screw

STEP
1

Step 10

● Parts Needed For ● Rear/Front Siding

- 9345 Rear Siding (6)
- 9746 Front Siding (6)

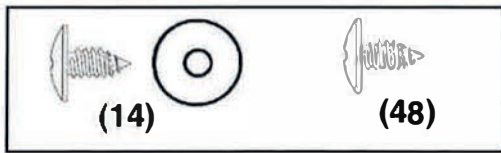

1 Slide **rear siding** into channel of corner and splice posts fastening to rear frame as shown in previous step.

2 Install **rear siding** to complete each section of rear wall. Fasten top center of last siding to rear angle.

3 Slide **front siding** into channels of corner post and door jamb. This siding is fastened from the inside, using screws into post and jamb.

4 Install **front siding** to complete both front sections.

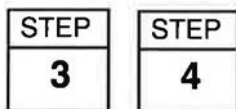
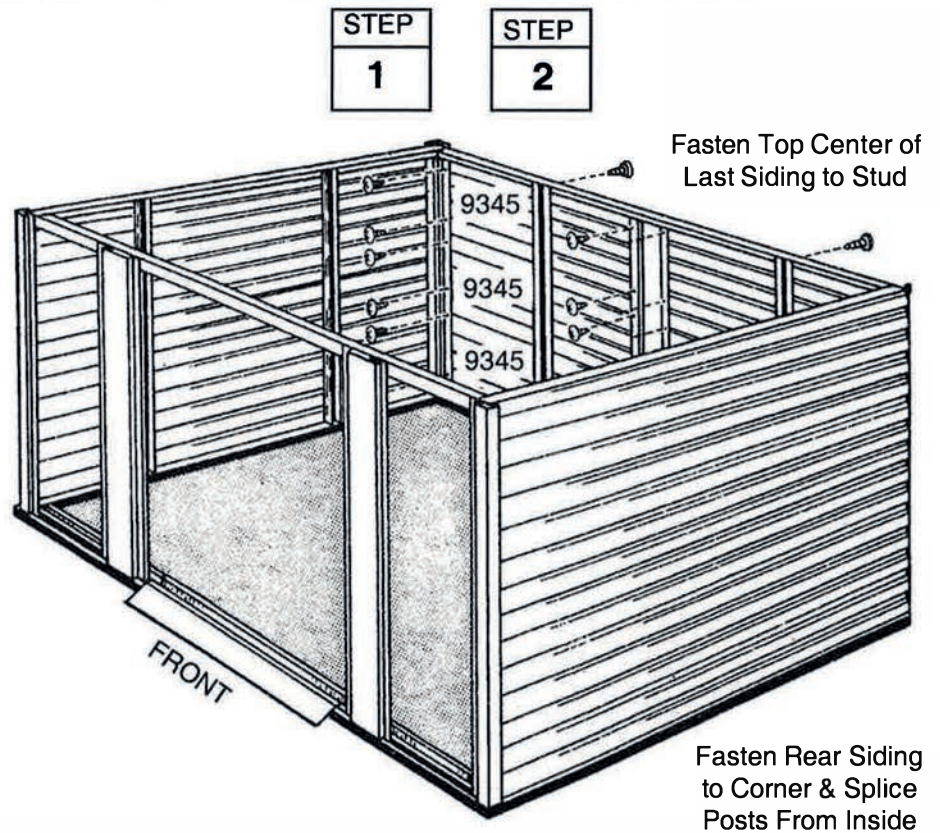

Front Panels Fasten at Corners & Door Jambes from the Inside

Step 11

● Parts Needed For ● Gable Assemblies

- 7906 Right Gable (2)
- 7907 Left Gable (2)
- 7916 Roof Beam Bracket (4)

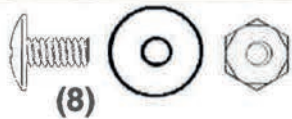

The gables go on top of the front and rear walls to support the roof beams.

NOTE

The gables are packed nested together and might be mistaken as one piece. Carefully separate them before continuing.

1 Attach the four **roof beam brackets** to the gables using two bolts, washers and nuts.

NOTE

Mounting leg of bracket must face toward center of gable

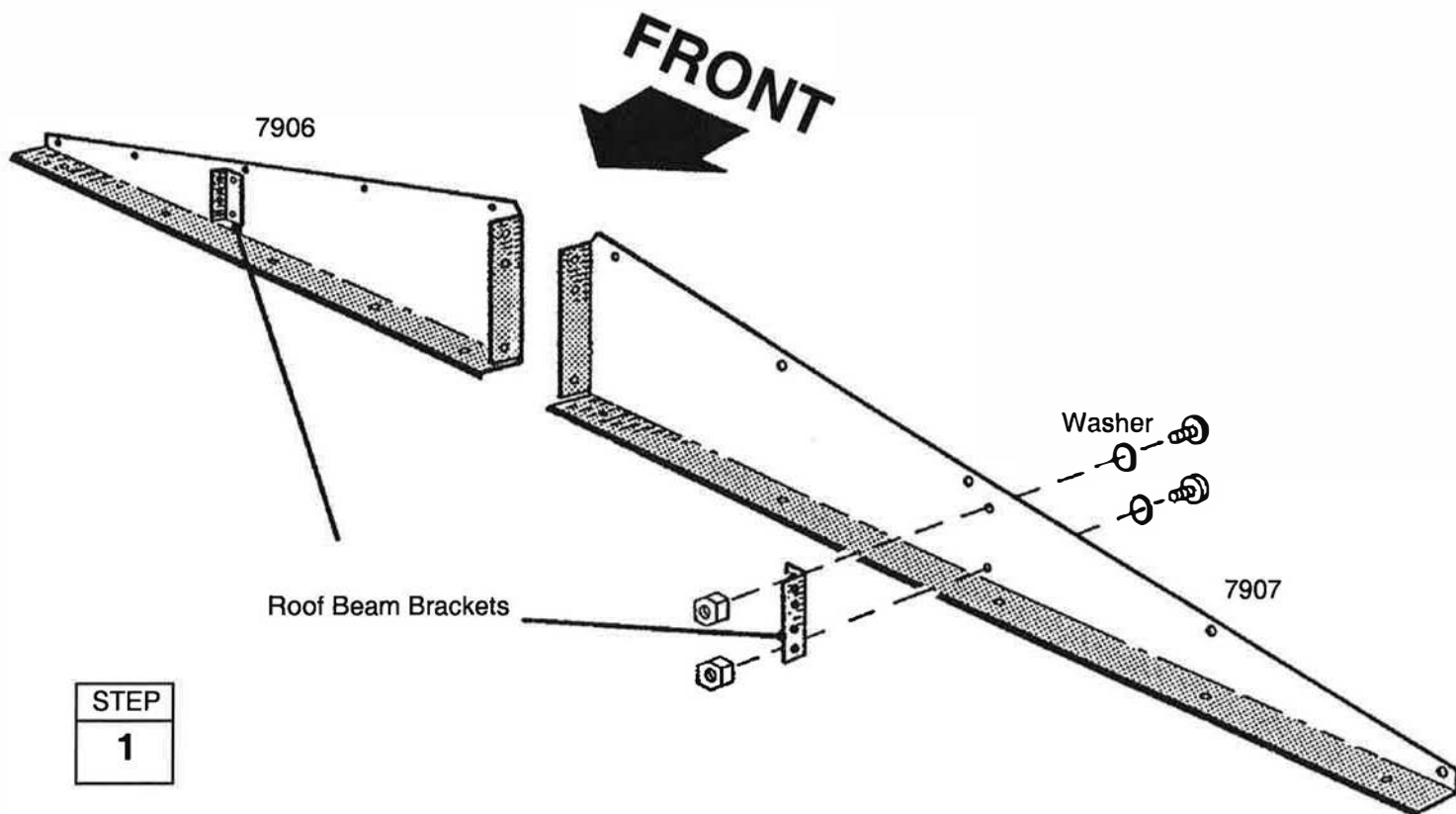

STEP

1

Step 12

● Parts Needed For ● Gables/Braces

- Left Gable Assemblies (2)
- Right Gable Assemblies (2)
- 6658 Gable Brace (2)



(24)



(7)

1 Lift and fasten a right and left gable, under angle at corner, to the rear wall angle with screws.

Hint: On the rear gable, use a bolt and nut at the overlapping rear wall angle. On the front gable, leave out 2 screws closest to center gable leg.

2 Join the **left** and **right gables** together with a **gable brace** using a bolt in the bottom two holes *only*.

3 Repeat Steps 1 & 2 for the door track on the front of building, except for the **track supports**, fasten as shown.



STEP
1

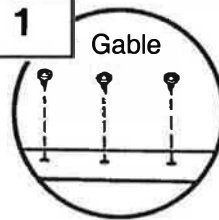

Gable

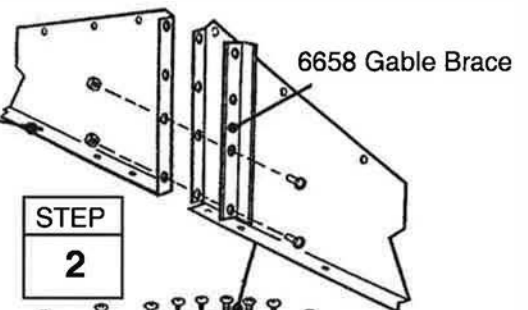

6658 Gable Brace

STEP
2

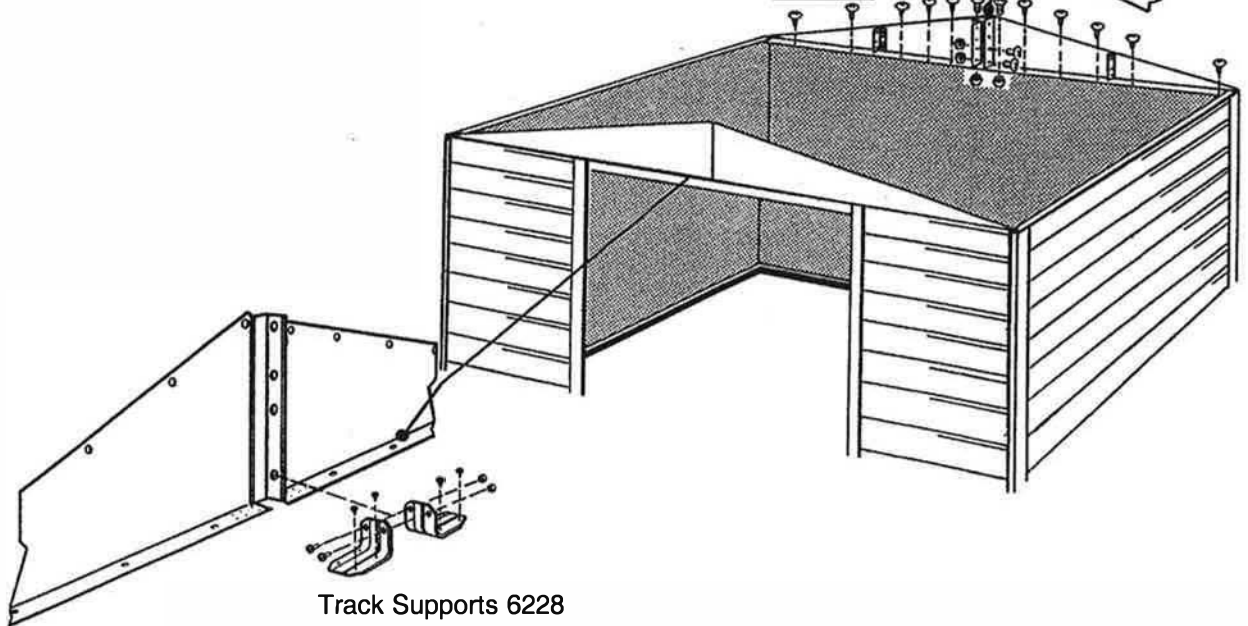

Track Supports 6228

STEP
3

Step 13

● Parts Needed For ● Roof Beams

- Main Roof Beam (1)
- 8474 Roof Beam (2)



(12)

1 Fasten the **main roof beam** to the gable brace of the front gable.

2 Fasten the other end of the main roof beam to the gable brace of the rear gable.

3 Fasten the remaining **roof beams** *small holes on top* as shown using bolts.

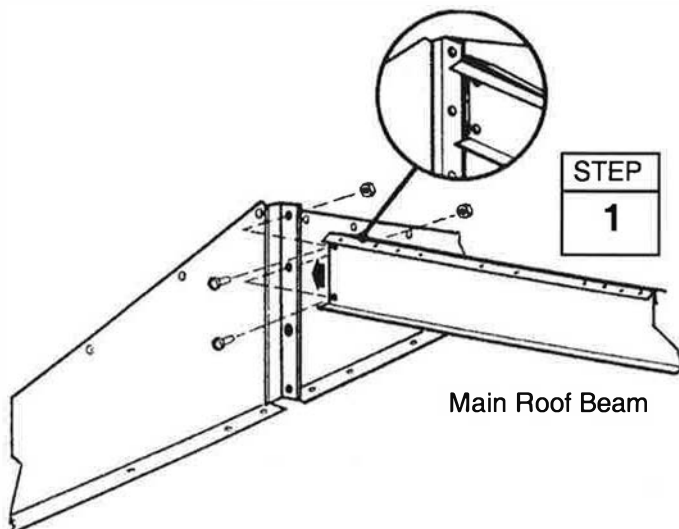
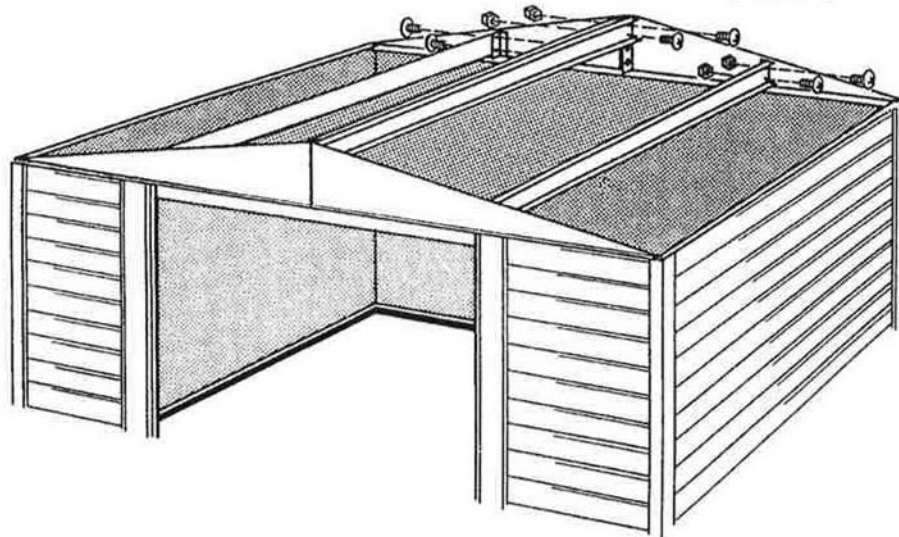
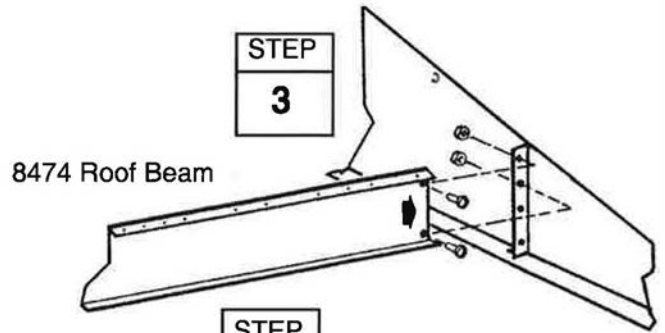

Step 14

● Parts Needed For ● Right Roof Panel

● 8466 Right Roof Panel (1)

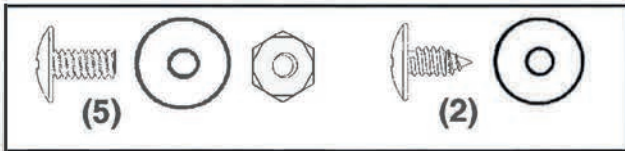

Installing the roof panels is best done with a step ladder. Begin installing roof panels at the back right corner of the building. Each screw and bolt in the roof requires a washer.

NOTE

Measure the building diagonally again and make adjustments to make sure the building is square and level. This will make the roof panels fit better, and holes will align. Don't anchor the floor frame.

NOTE

If a **Roof Beef-Up Kit** was purchased, assemble prior to attaching the roof panels.

1 Locate the roof panels by their numbers. *Note the sequence and position they are to be installed.*

2 Position the **right roof panel** at the back right corner and fasten to the gable with 5 bolts and nuts and roof beams using 2 screws. *Do not fasten the lower end of the panel to the side wall angle at this time.*

Hint: Attach fasteners in order shown in diagram.

STEP
1

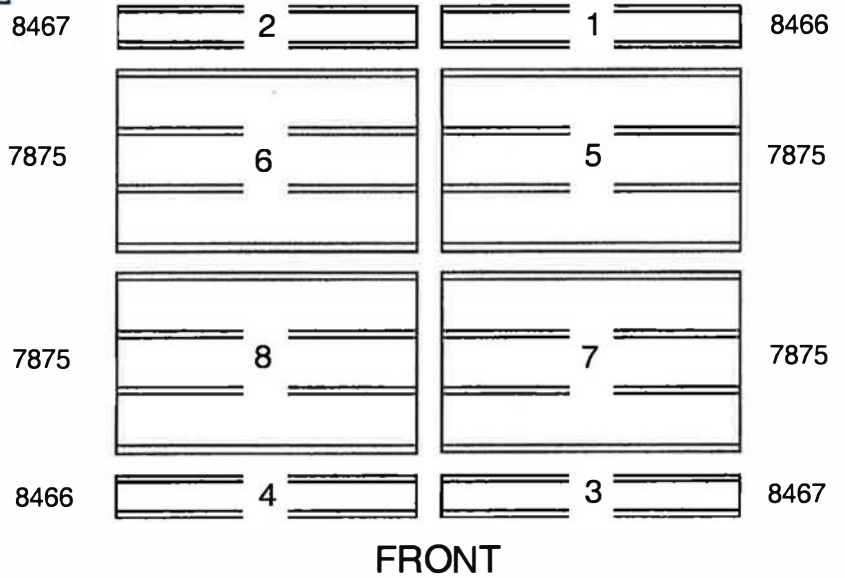

STEP
2

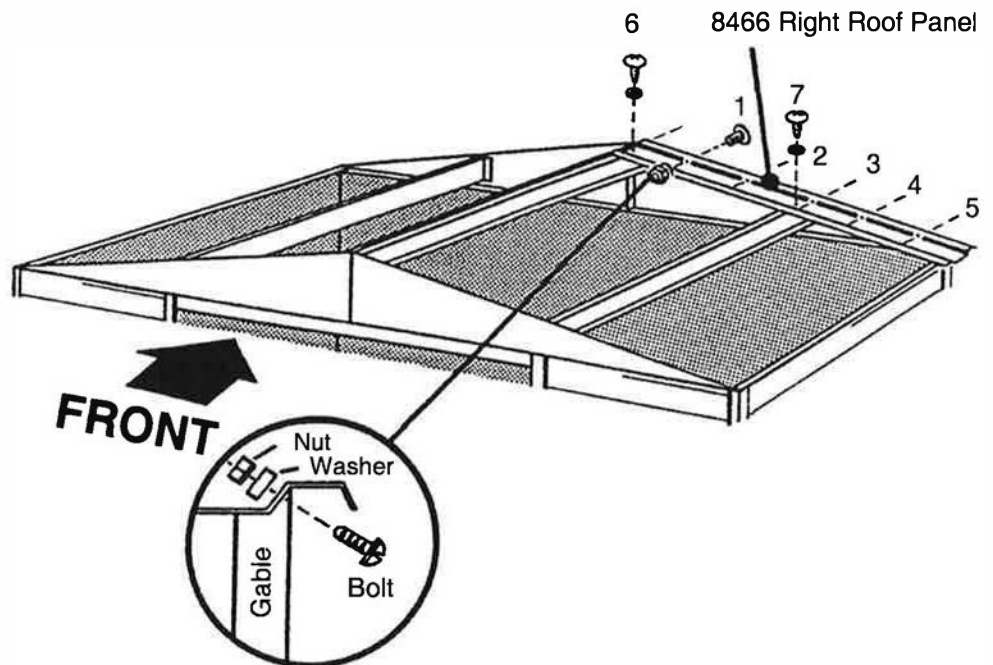

Step 15

● Parts Needed For ● Roof Assembly

- 8467 Left Roof Panel (2)
- 7875 Roof Panel (4)
- 8466 Right Roof Panel (1)



1 Install a **left roof panel** at the left rear and right front corner of the roof. Install a **right roof panel** at the left front corner of the roof.

2 Cut 2 short 2" (5,1 cm) strips off the roll of **weather stripping tape**, and put them aside. Cover the joint at the peak with weather stripping tape. Unroll the tape and press it down over the opening at the ridge as you install each roof panel. Do not cut the tape at this time.

3 Install 4 **roof panels** in the sequence and positions shown on previous page. *Do not fasten the lower end of the panels to the side wall angles at this time.* Continue weather stripping the ridge opening. Fasten roof panel overlaps not used for ridge cap (roof center). Cover the head of bolt with the 2" (5,1 cm) piece of weather stripping tape.

STEP
1

8467 Left Roof Panel

Weather Stripping
Tape Roll

STEP
2

8466 Right
Roof Panel

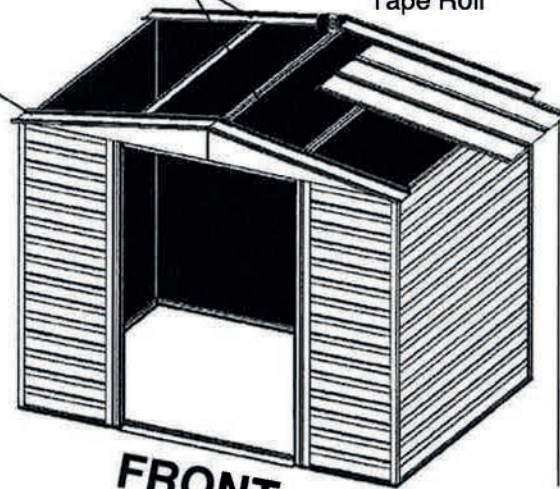

7875 Roof Panel

STEP
3

Screws To
Roof Beam

Fasten At
Overlap with
Bolt

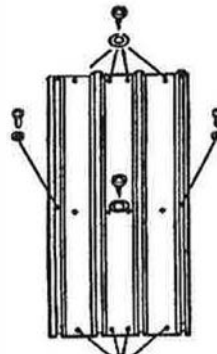

Fasten At
Overlap with
Bolt

Screws To
Roof Beam

Do not fasten
at this time

Strips

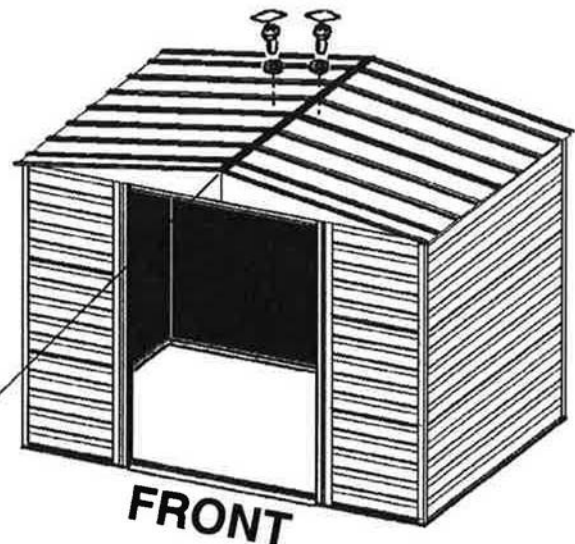

Cut
Weather Stripping
and Fold Under

NOTE

Narrow roof panel crimped rib is overlapped by wide rib of adjacent panel where possible.

NOTE

If roof beam holes do not line up with the roof panel holes, shift the building from left to right. If this does not help, your building may not be level. Shim the corners until holes line up.

Step 16

● Parts Needed For ● Ridge Cap/Roof Trim

- 8461 Ridge Cap (1)
- 8482 Side Roof Trim (2)

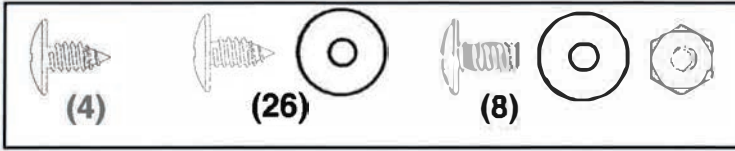

1 Install the **ridge cap** on the completed roof section using bolts. Do not fasten the ends of the ridge cap until instructed to do so.

2 Fasten the lower end of the panels to the side wall angles using screws and washers.

3 Attach the **side roof trim** to the lower end of the roof panels on each side of the building using screws at each panel overlap.

4 Using your thumb and index finger, overbend the bottom flange of the side roof trim at the corner inward enough so the right and left roof trim caps fit onto right and left corners.

5 Fasten the roof trim caps to the side trim using a screw.

6 Fasten the roof panel rib, **peak cap** and ridge cap together using bolts and nuts. Fasten the remaining peak cap in the same manner.

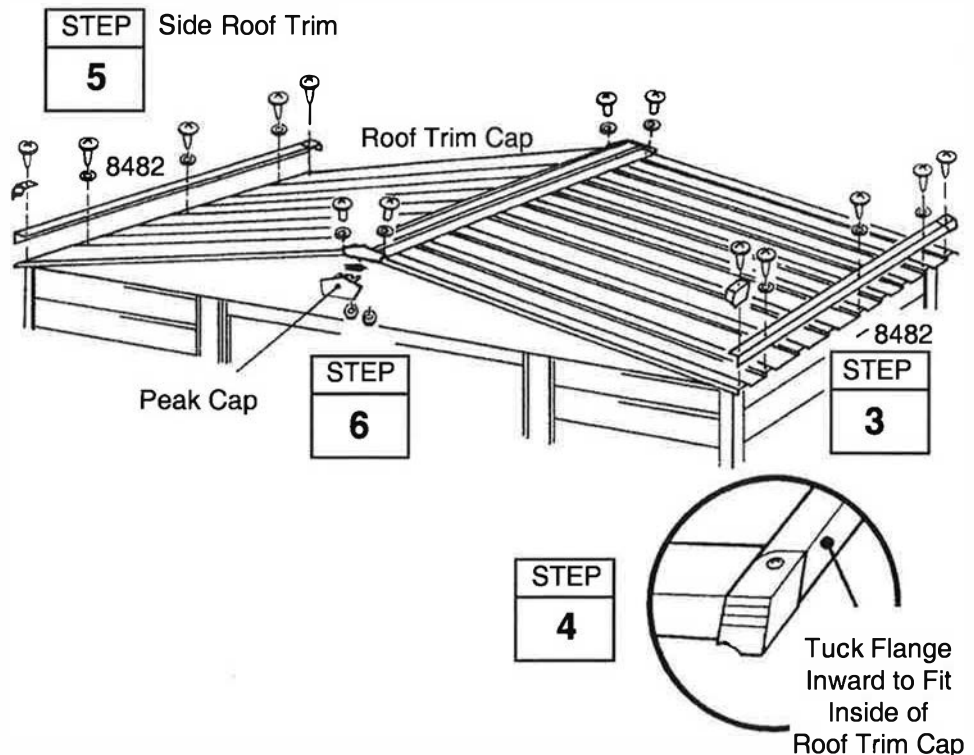
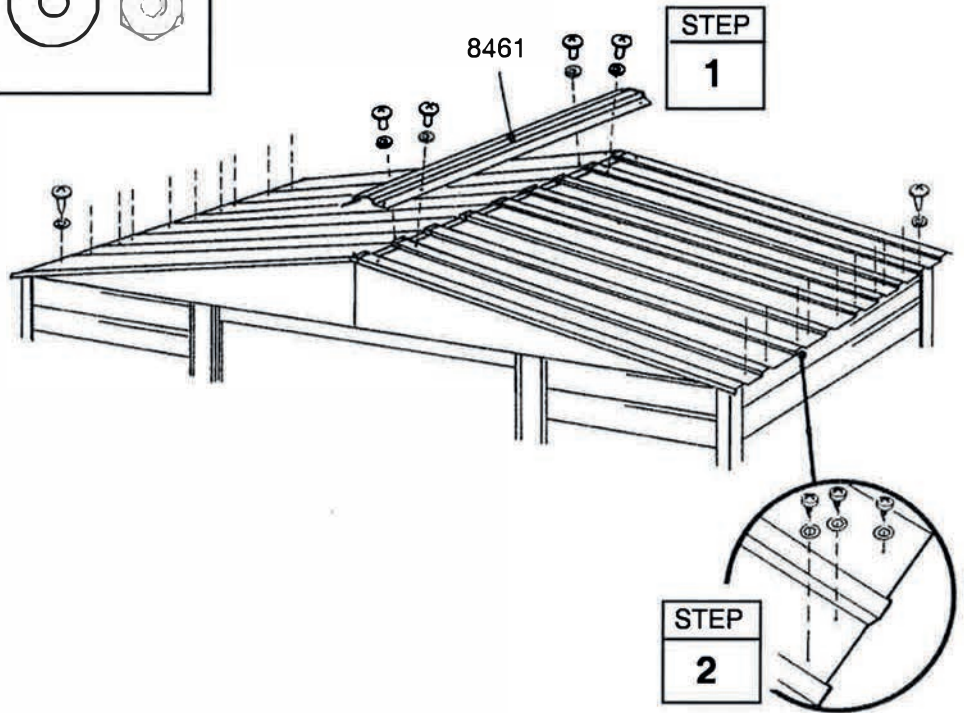

Step 17

● Parts Needed For ● Door Assembly

- 10484 Right and Left Doors (2)
- 10498 Horizontal Door Brace (4)
- 6301 Vertical Door Brace (2)

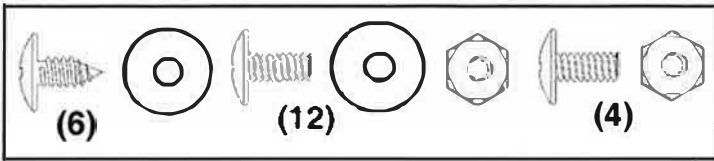

The steps on this page tell how to assemble the right door. You will perform exactly the same procedures for the left door. Each bolt and screw in the door requires a washer. Proceed as follows:

1 Attach the **handle** to the **door** with 2 bolts and nuts as shown.

2 Hold the **vertical door brace** against the center of the inside surface of the door and turn the screw to hold the vertical door brace in place. Fasten to door above and below center connection using 2 screws.

3 Put a **horizontal door brace** onto the top edge *and* bottom edge and fasten *with 1 bolt in the center*.

4 Attach the **lower door guides and bolts** as shown.

5 Repeat steps 1 through 4 for the **left door**.

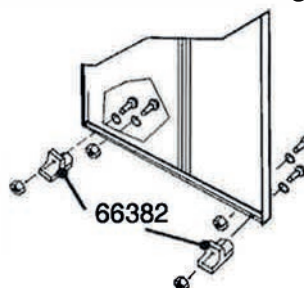
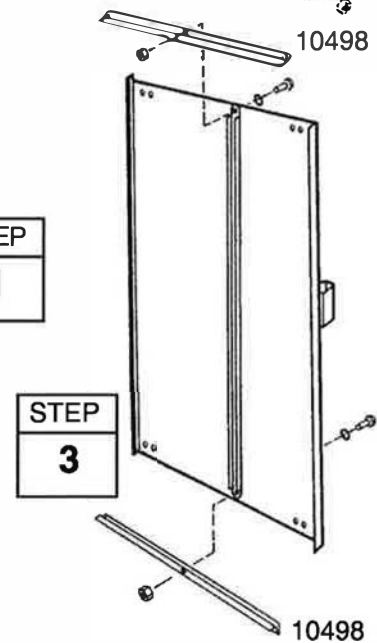
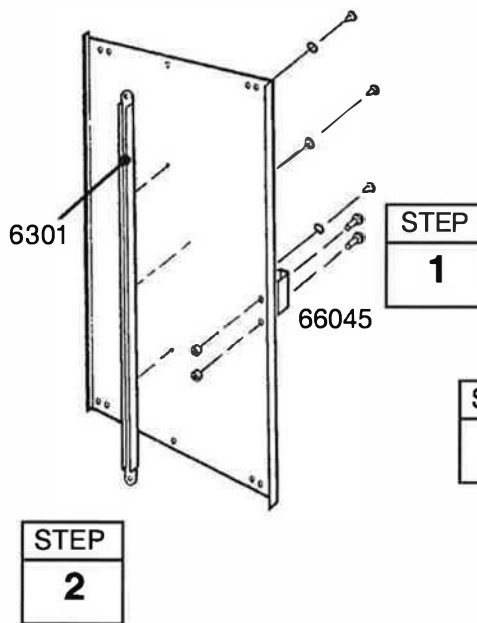
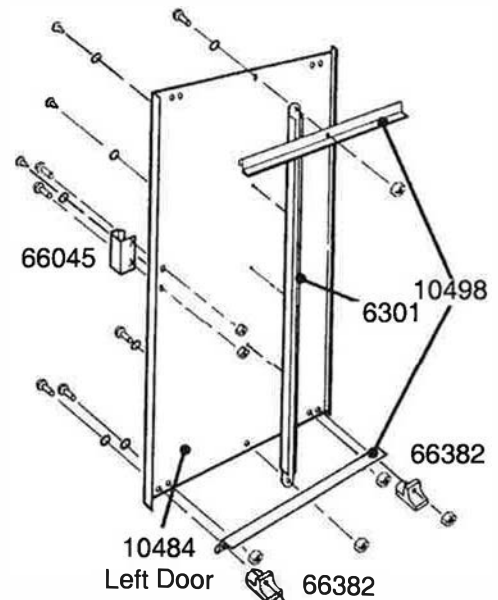
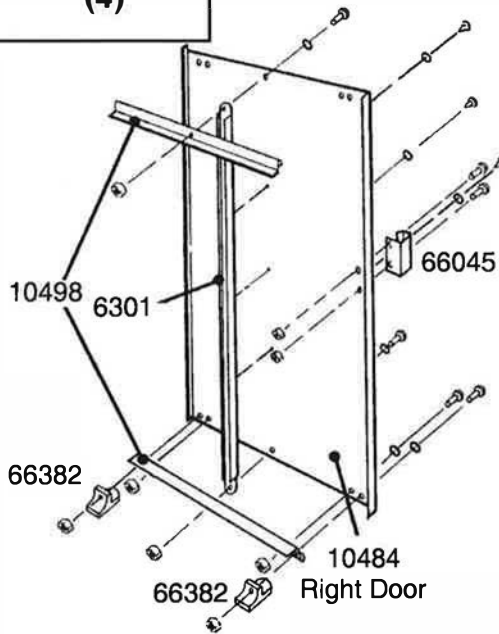

END VIEW
SHOWING:



Step 18

● Parts Needed For ● Door Installation & Adjustment

- Right Door Assembly (1)
- Left Door Assembly (1)

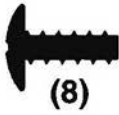

1 From inside the building, put the bottom of the right door assembly (on your left when you are inside the building) behind door jamb into the front frame track.

2 Position the top of the door so that the holes in the door line up with the holes in the door slides.

3 Fasten the door to the door slides using two #10Bx1/2" (13 mm) screws per door slide.

NOTE

The holes in the door slides allow you to adjust the doors. Place the door in the middle holes.

4 Repeat steps 1 through 3 for the left door.

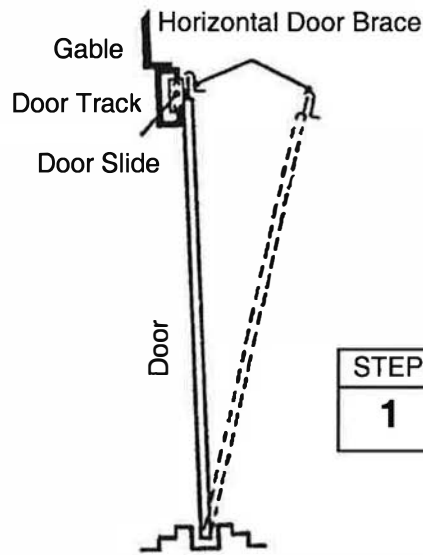

STEP
1

STEP
2

Front Floor Frame Assembly

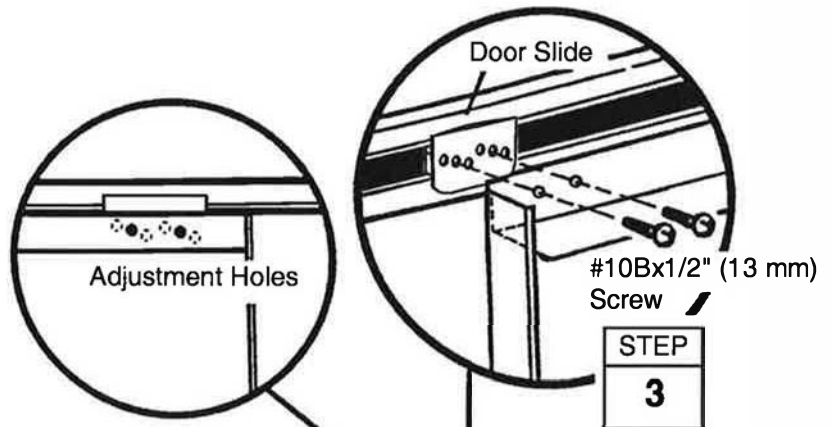

Adjustment Holes Allow Doors to Meet Evenly Along Their Length

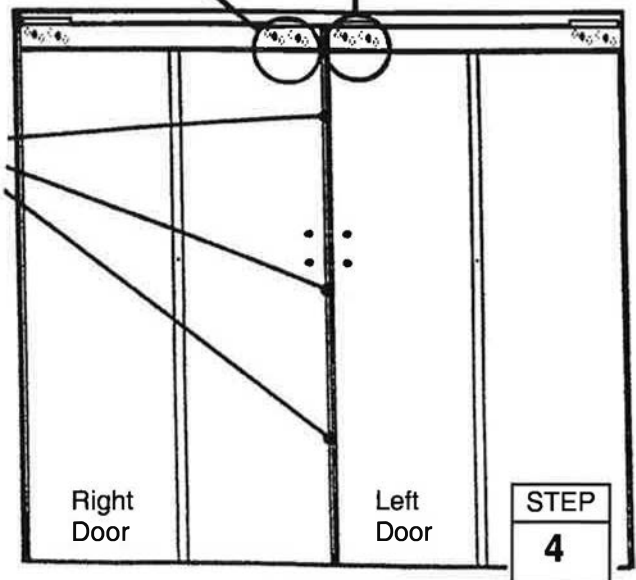

Keep this Owner's Manual and Assembly Instructions for future reference.

Anchoring and Floor Frame

Anchoring

Anchor your building at this time.

Floor Frame

If you have purchased a Floor Frame Kit you need to install it at this time.

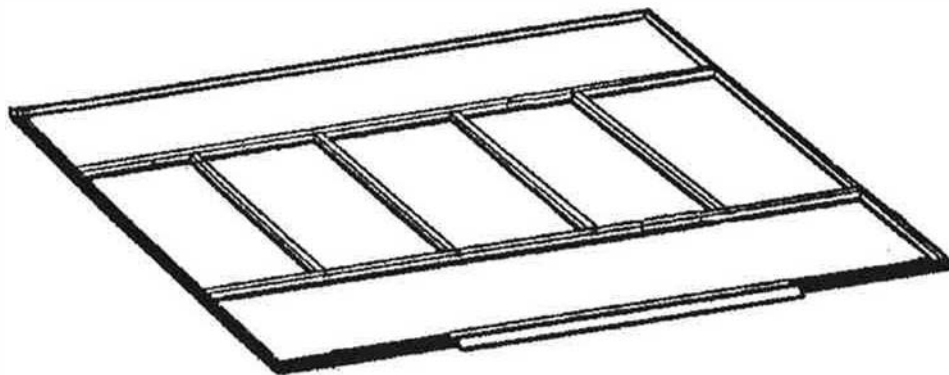

SOME FACTS ABOUT RUST

Rusting is a natural oxidizing process that occurs when bare metal is exposed to moisture. Problem areas include screw holes, unfinished edges, or where scrapes and nicks occur in the protective coating through normal assembly, handling and use. Identifying these natural rusting problem areas and taking some simple rust protection precautions can help to stop rust from developing, or stop it quickly as soon as it appears.

1. Avoid nicking or scraping the coating surface, inside and out.
2. Use all the washers supplied. In addition to protecting against weather infiltration, the washers protect the metal from being scraped by the screws.
3. Keep roof, base perimeter and door tracks free of debris and leaves which may accumulate and retain moisture. These can do double damage since they give off acid as they decay.
4. Touch up scrapes or nicks and any area of visible rust as soon as possible. Make sure the surface is free of moisture, oils, dirt or grime and then apply an even film of high quality touch-up paint.