

Owner's Manual & Assembly Instructions

Roof Beef-Up Kit

Model No. **RBK6586**



FOR 6x5 & 8x6 BUILDINGS

RBK10610



FOR 10x6, 10x8, 10x9 & 10x10 BUILDINGS

RBK1012



FOR 10x12 BUILDINGS

RBK1014



FOR 10x13 & 10x14 BUILDINGS

697.68207



FOR 10x6, 10x8, 10x9 & 10x10 BUILDINGS



This Roof Beef Up Kit is required to meet certain building code requirements relating to snow load factors. It accomplishes this by providing additional roof beams and gable braces. The parts provided in the kit are related to the standard model building so you should refer to both the standard assembly instructions and this booklet when assembling your building. Various parts must be notched as shown in the following steps, prior to assembly on the building. Wear work gloves, eye protection and long sleeves when cutting and handling the metal parts.

NOTE

This kit may be installed in buildings that have already been constructed. It will be necessary to remove the roof panels to accomplish this.

Parts and Parts List: Check to be sure that you have all the necessary parts for your Roof Beef Up Kit.

- All part numbers can be found on the parts. All of these numbers must agree with the numbers on the parts list.
- If you find that a part is missing, include the model number of this kit and contact:

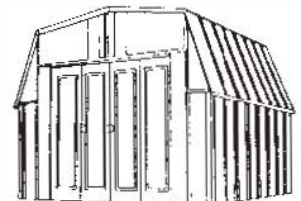
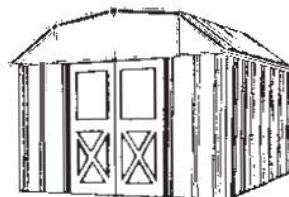
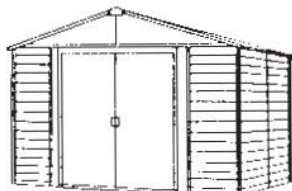

Parts List

RBK6586

Assembly Key No.	Part Number	Part Description	Quantity in Carton	Check List
1	9735	Roof Beam 1x2 37 3/4"	6	

RBK10610 697.68207

Assembly Key No.	Part Number	Part Description	Quantity in Carton	Check List
1	6636	Gable Brace 23 7/8"	8	
2	9736	Roof Beam 1x4 60 5/8"	12	

RBK1012

Assembly Key No.	Part Number	Part Description	Quantity in Carton	Check List
1	6636	Gable Brace 23 7/8"	8	
2	9737	Roof Beam 1x4 142 3/8"	6	

RBK1014

Assembly Key No.	Part Number	Part Description	Quantity in Carton	Check List
1	6636	Gable Brace 23 7/8"	8	
2	6314	Roof Beam 1x4 159 3/8"	6	

Hardware



65004

#8x5/16" Screw

RBK6586	(16)
RBK10610, 697.68207	(17)
RBK1012	(104)
RBK1014	(25)



65103

#8-32 Hex Nut

(31)
(66)
(54)
(54)



65923

#8-32x3/8" Bolt

(31)
(66)
(54)
(54)

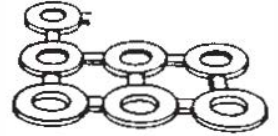

66646

Washer

(160)
(240)
(240)
(320)



66611

#10x1/2" Screw

RBK6586	(62)
RBK10610, 697.68207	(171)
RBK1012	(54)
RBK1014	(241)

These larger screws are only required for buildings that have already been constructed and it was necessary to remove the roof panels. Where a #8x5/16" screw was removed, replace with a #10x1/2" screw.

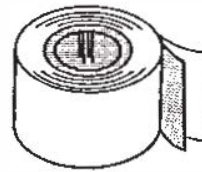

67293/67545

Weather Stripping

(1)/(0)
(1)/(1)
(0)/(1)
(1)/(2)

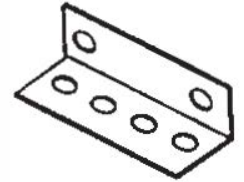

7916

Gable Brace

(4)

Tools

The following tools are required to complete the installation of this Roof Beef Up Kit in your building in addition to those listed in the standard manual for this building.



Tin Snips
(Heavy Duty)

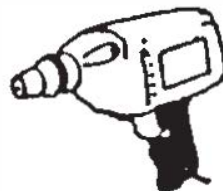

Drill



Drill Bits
7/32" - 3/32" Diameters

RBK6586

● Parts Needed For ● Roof Beam Assemblies

● 9735 Roof Beam (6)

The roof beams join the two gables and support the roof panels. Proceed as follows:

NOTE

The roof beams packed with the standard building and additional roof beams packed with this kit *must* be used, to accomplish installation.

Hint: These pieces are force-fitted, so you may have to press hard to join them together.

1 Place the end of a **roof beam** inside another **roof beam**. Telescope them to a length of 56 1/8" for the 6x5 building or 67 7/8" for the 8x6 building, so that six holes in each piece align. Make three sets of roof beams by repeating this procedure. Do not fasten together at this time.

9735

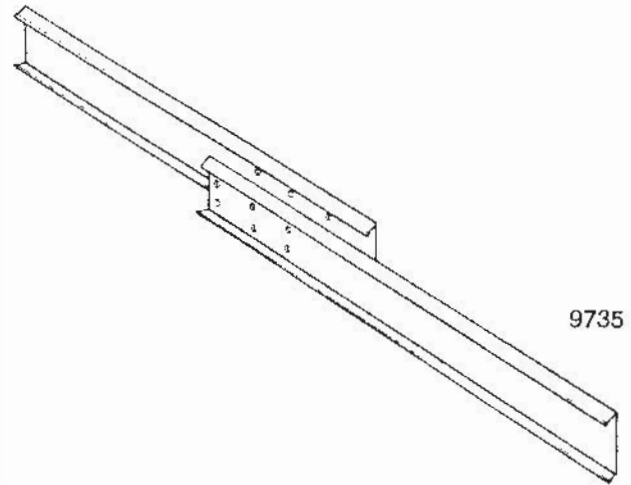

9735

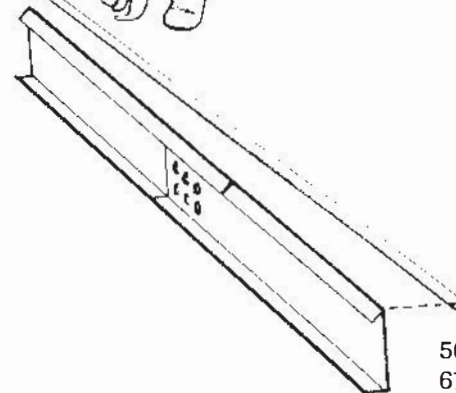
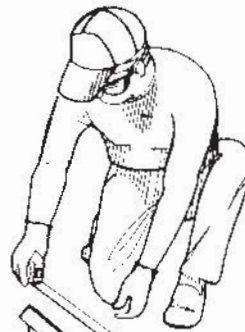

56 1/8" (6x5)
67 7/8" (8x6)

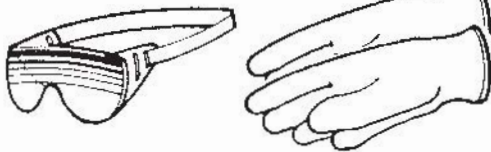

NOTE

Don't forget to wear your gloves and safety goggles.

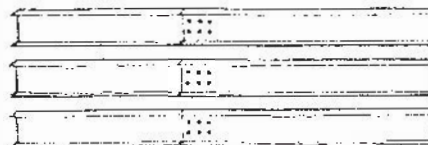

RBK6586

● Parts Needed For ● Roof Beam Installation

- 7916 Gable Brace (4)
- Roof Beam Assemblies (3)

NOTE

This step to be done in conjunction with Steps #8 and #9 in the standard assembly instructions for the 6x5 building and #12 & #13 for 8x6 building.

REMINDER

If your building has already been constructed, at this point you must remove roof panels.

1 Install gables as outlined in the standard assembly instructions for your building.

2 On the 6x5 and 8x6, install the **beef up roof beam assembly**, back-to-back, in place of the roof angle from the standard building as outlined in the assembly instructions for your building. Use bolts and nuts to fasten the roof beams to the legs of the gables and braces. Using the six holes in the beef up beam as a guide, with a $7/32$ " diameter drill bit, drill through the six holes, and fasten beams together using six bolts and nuts.

3 On the 6x5, position **gable brace** $16\ 3/4$ " over from the main center roof beam on inside of the gable with leg pointing toward the center of the building. Mark two holes and with a $7/32$ " diameter drill bit, drill two holes into the face of the gable. See diagram for location.

4 On the 6x5, fasten **gable brace** to the gable using two bolts and nuts.

NOTE

Repeat item #3 and #4 on the other three gables

5 On the 6x5, fasten remaining **beef up roof beam assemblies** to the **gable braces** using bolts and nuts. Fasten six aligned holes on beam, using bolts and nuts.

6 On the 8x6, position the **beef up roof beam assemblies**, back-to-back, with the roof beam from the standard building as outlined in the assembly instructions for your building. Use bolts and nuts to fasten the roof beams to the legs of the roof beam brackets. Using the six holes in the beef up beam as a guide, with a $7/32$ " diameter drill bit, drill through the six holes, and fasten beams together using six bolts and nuts.

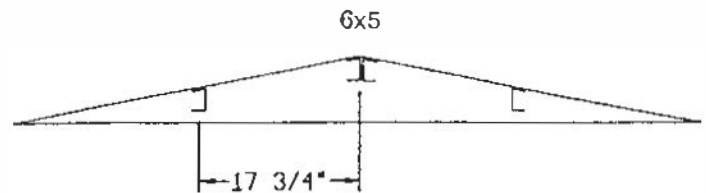
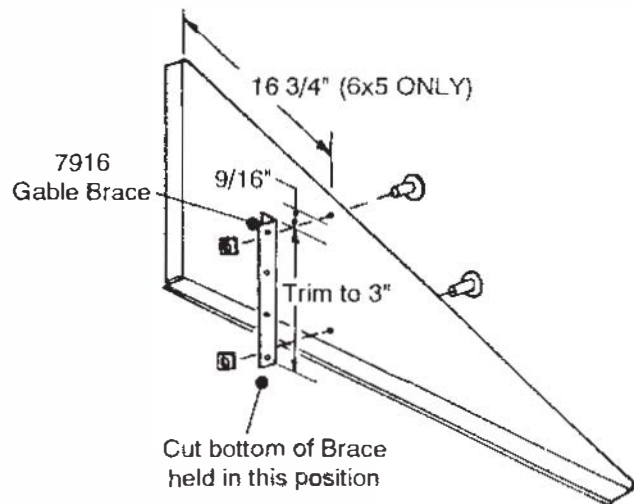

POSITION OF (4) 2" BEAMS

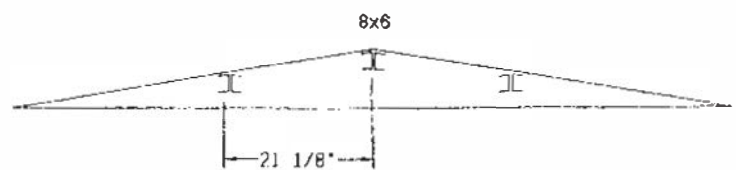

POSITION OF (6) 2" BEAMS

RBK6586

Roof Panel Installation

NOTE

Each screw and bolt in the roof requires a washer

NOTE

If your building has already been constructed and you had to remove the roof panels, use the larger #10Ax1/2" screws to replace the #8Ax5/16" screws that were removed

1 Using Step #10 in the standard assembly instructions for the 6x5 as a guideline, or Step #14 in the 8x6, install a right roof panel at the back right corner of the building.

2 Fasten this right roof panel to the main roof beam assembly (6x5 & 8x6 labeled #1 in the diagram), and to the double roof beam in the 8x6, using screws and washers.

3 On the 6x5, using a 3/32" diameter drill bit, drill a hole through the roof panel and into the roof beam (labeled #2 in the diagram). Fasten the roof panel to the roof beam in this new hole using a screw and washer.

4 Install the remainder of the roof panels as outlined in Steps #11 and #12 of the standard assembly instructions for 6x5 building, or Step 15 for the 8x6 building, with the following exception.

NOTE ON THE 6x5

As described in item #3 of this step you *must* drill 3/32" diameter holes and fasten with #8Ax5/16" screws and washers to the additional roof beams labeled #2 in the diagram.

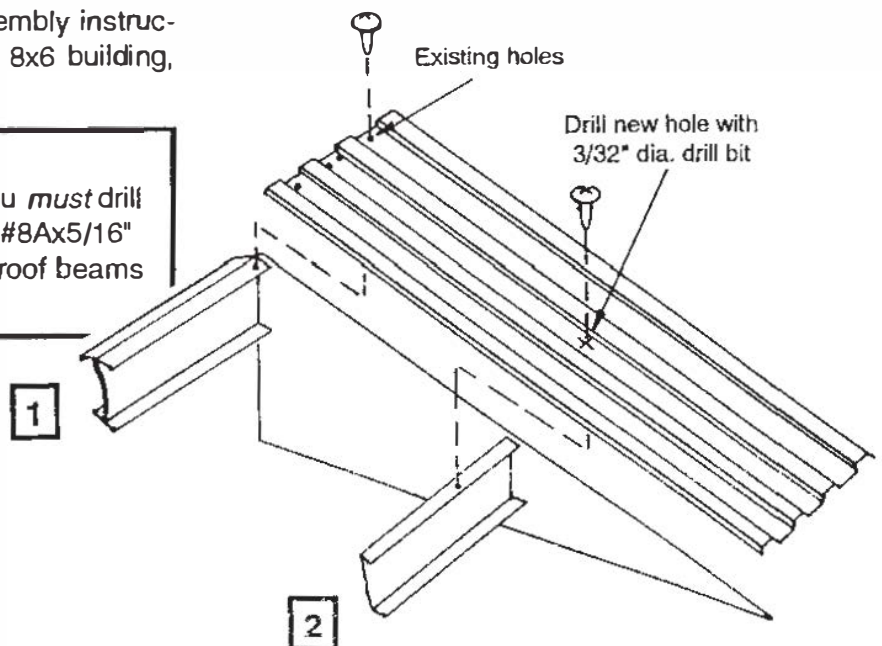

RBK10610

697.68207

● Parts Needed For ● Roof Beam Assemblies

● 9736 Roof Beam (twelve)

The roof beams join the two gables and support the roof panels. Proceed as follows:

NOTE

The roof beams packed with the standard building and additional roof beams packed with this kit *must* be used, to accomplish installation.

Hint: These pieces are force-fitted, so you may have to press hard to join them together.

1 Place the end of a **roof beam** inside another **roof beam**. Telescope them to a length of 67 7/8" for the 10x6, 91 7/8" for the 10x8, 104 1/8" for the 10x9, or 113 5/8" for the 10x10 building, so that six holes in each piece align. Make six sets of roof beams by repeating this procedure. Do not fasten together at this time.



NOTE

Don't forget to wear your gloves and safety goggles.

9736

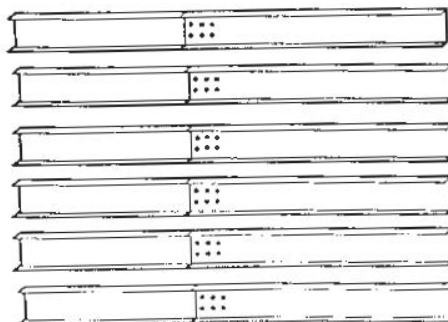
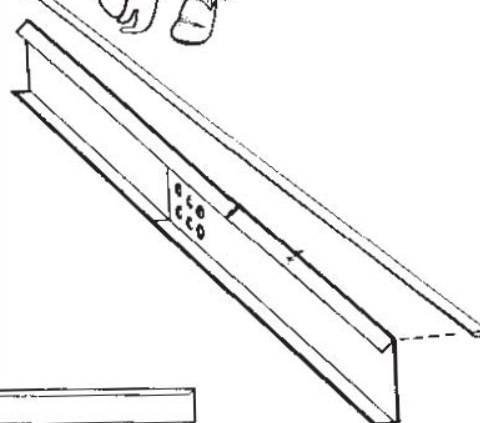
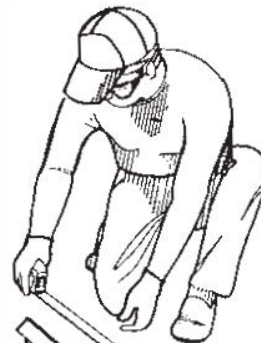
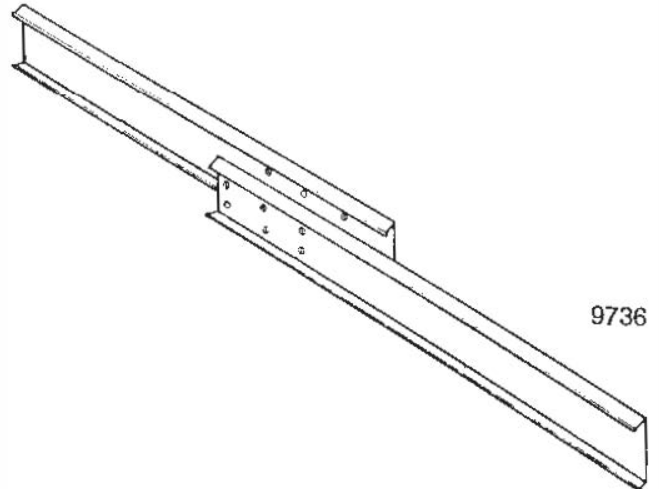

67 7/8" (10x6)
91 7/8" (10x8)
103 15/16" (ES109, 697.68171)
104 1/8" (10x9)
113 5/8" (10x10)

RBK10610

697.68207

● Parts Needed For ● Roof Beam Installation

- 6636 Gable Brace (eight)
- Roof Beam Assemblies (six)

NOTE

This step to be done in conjunction with Steps for Gables/Braces and Roof Beams in the standard assembly instructions for your building.

REMINDER

If your building has already been constructed, at this point you must remove roof panels.

1 On the 10x6, 10x8, 10x9 & 10x10 Low 9" Gable, install gables as outlined in the standard assembly instructions for your building.

2 Position gable brace 16" and 45 1/2" over from the main center roof beam on inside of the gable with leg pointing toward the center of the building. Cut gable brace to appropriate dimension shown, using tin snips. Mark two holes and with a 7/32" diameter drill bit, drill two holes into face of the gable. Fasten gable brace to the gable using two bolts and nuts. See diagram.

NOTE

Repeat item #2 on the other three gables.

3 Fasten beef up roof beam assemblies to the gable braces, using bolts and nuts. Notch beam at 45 1/2". Fasten six aligned holes on beam, using bolts and nuts.

4 Position the remaining beef up roof beam assemblies, back-to-back, with the roof beam from the standard building as outlined in the assembly instructions for your building. Use bolts and nuts to fasten the roof beams to the legs of the roof beam brackets. Using the six holes in the beef up beam as a guide, with a 7/32" diameter drill bit, drill through the six holes (where needed), and fasten beams together using six bolts and nuts.

1 On the 10x8 & 10x9 High 17 1/2" Gable, follow Steps #1 through #4 above with the following exception. Position gable brace 13 3/4" and 43 1/4" over from the main center roof beam on inside of the gable with leg pointing toward the center of the building.

Mark three holes and with a 7/32" diameter drill bit, drill three holes into face of gable. Fasten gable brace to the gable using three bolts and nuts.

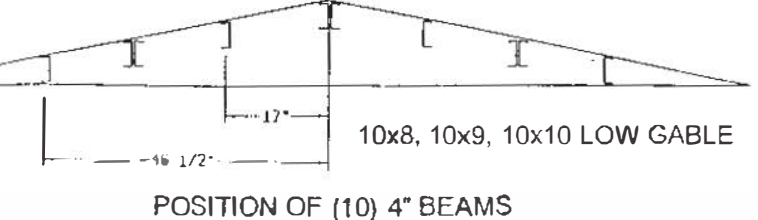
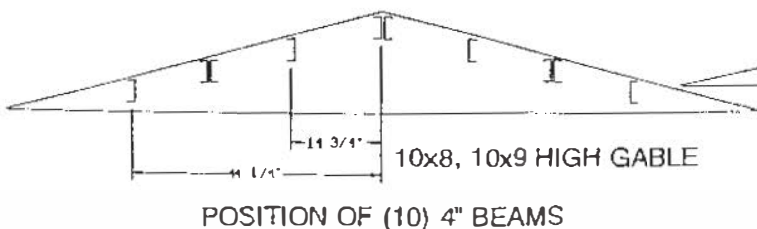
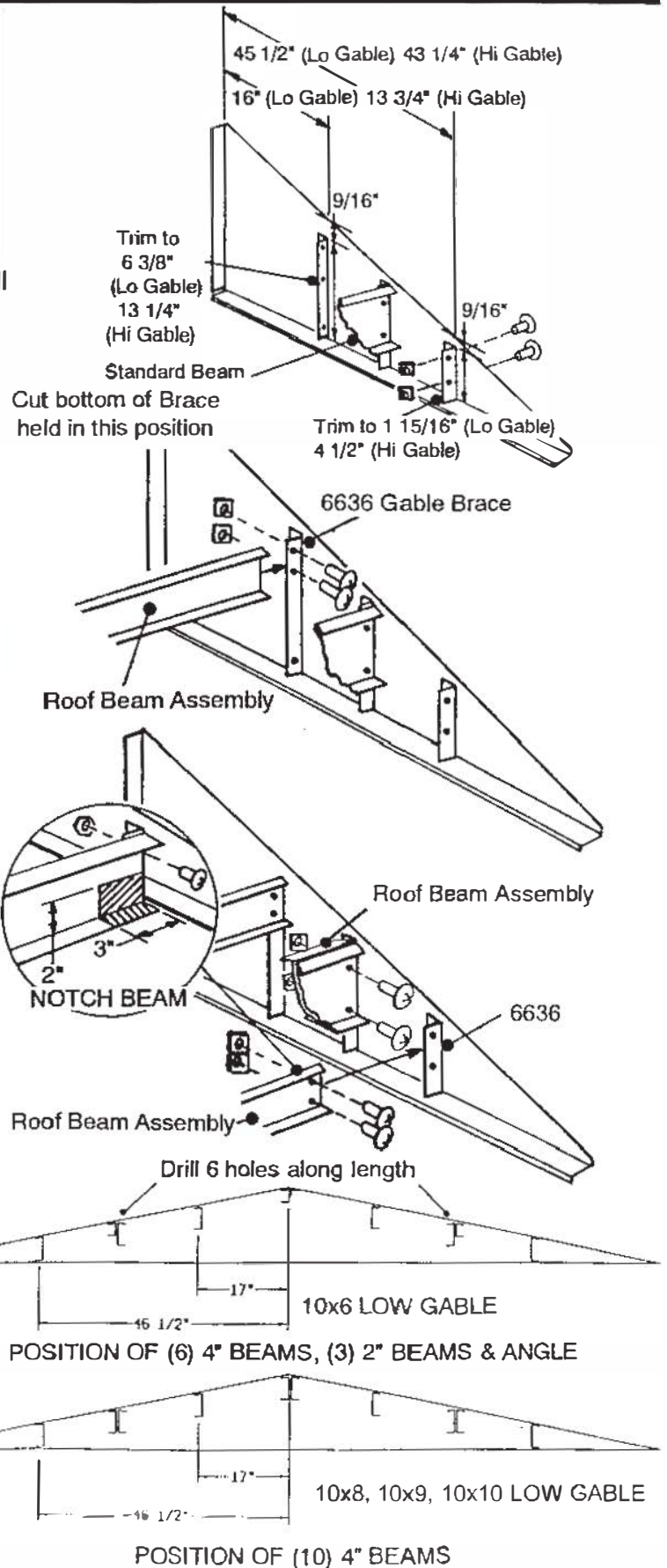

RBK10610

697.68207

● Parts Needed For ● Roof Beam Installation

- 6636 Gable Brace (four)
- Roof Beam Assemblies (six)

1 On the 10x8 & 10x9 High Gambrel, install gables as outlined in the standard assembly instructions for your building.

2 Position **gable brace** 14 5/8" on the 10x8 & BF109 (24 1/4" on the 10x9) over from main center beam on inside of gables with leg pointing toward the center of the building. Mark three holes and with a 7/32" diameter drill bit, drill three holes into the face of the gable. Fasten gable brace to the gable using three bolts and nuts.

NOTE

Repeat item #2 on the other three large gables.

3 On the 10x8 & BF109, fasten two **beef up roof beam assemblies**, back-to-back, to the **gable brace**, using bolts and nuts. Repeat on opposite side of building.

4 On the 10x8 & BF109, position the remaining **beef up roof beam assemblies**, back-to-back, with the roof beam from the standard building as outlined in the assembly instructions for your building. Use bolts and nuts to fasten the roof beam to the legs of the roof beam brackets.

5 On the 10x9, fasten single **beef up roof beam assembly** to the **gable brace**, using bolts and nuts. Repeat on opposite side. Fasten beams at six holes.

6 On the 10x9, position the remaining **beef up roof beam assemblies**, back-to-back, with the roof beams from the standard building as outlined in the assembly instructions for your building. Use bolts and nuts to fasten the roof beams to the legs of the roof beam brackets.

Note: On items 3, 4 & 6, using the six holes in the beef up beam as a guide, with a 7/32" diameter drill bit, drill through the six holes (where needed), and fasten beams together using six bolts and nuts.

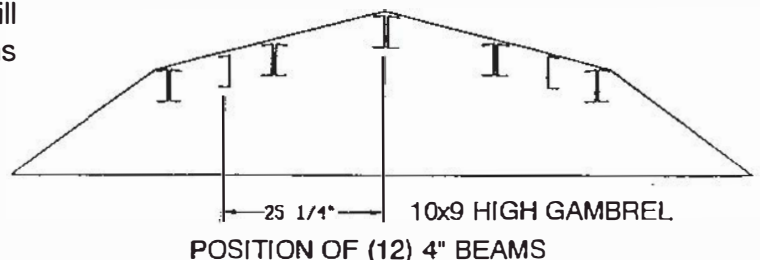
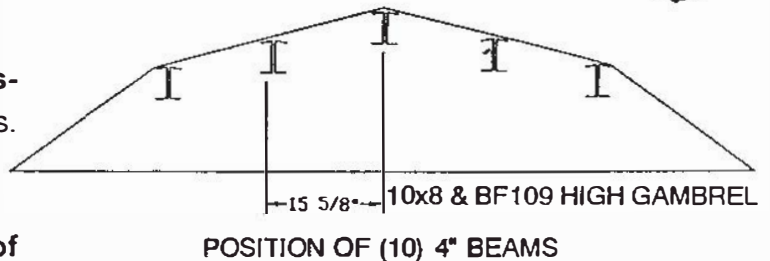
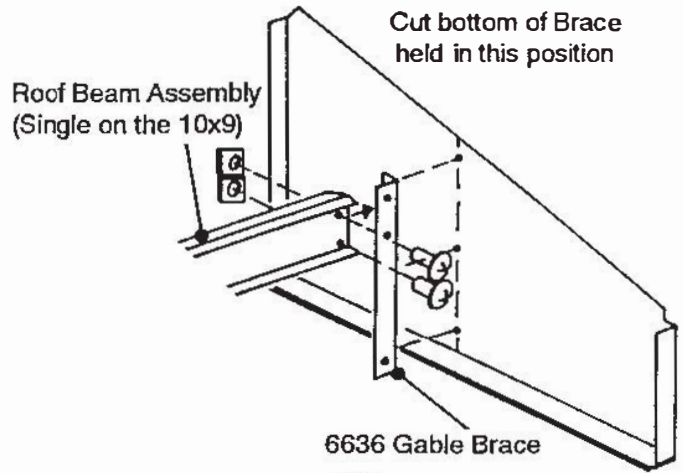
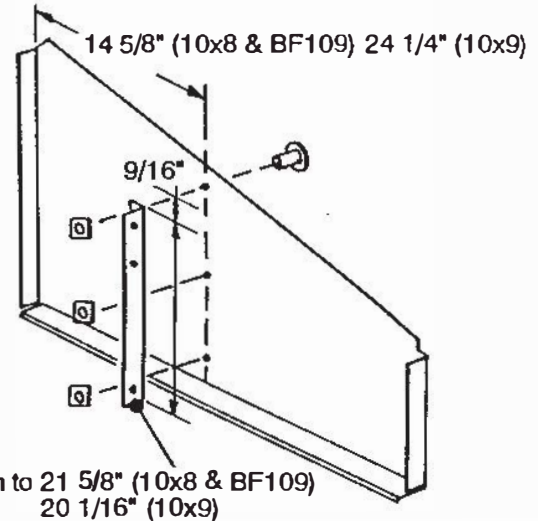

RBK10610

697.68207

● Parts Needed For ● Roof Beam Installation

- 6636 Gable Brace (eight)
- Roof Beam Assemblies (six)

1 On the ES109 & 697.68171, install gables as outlined in the standard assembly instructions for your building.

2 Position **gable brace** 10 3/4" and 33 1/4" over from main center beam on inside of gables with leg pointing toward the center of the building. **Mark** three holes and with a 7/32" diameter drill bit, drill three holes into the face of the gable. Fasten gable brace to the gable using three bolts and nuts.

NOTE

Repeat item #2 on the other three gables.

3 On the ES109, fasten single **beef up roof beam assemblies**, to the **gable braces**, using bolts and nuts. Repeat on opposite side of building.

4 On the ES109, the remaining **beef up roof beam assemblies**, replace the standard 2" beams at the break between gables (with small holes up). Install the two 2" beams back-to-back with the other 2" beams at the 23 3/4" location.

5 On the 697.68171, fasten single **beef up roof beam assembly** to the **gable brace** (at 10 3/4") using bolts and nuts. Repeat on opposite side of building.

6 On the 697.68171, position the remaining **beef up roof beam assemblies**, back-to-back, to the **gable brace** (at 33 1/4") using bolts and nuts. Repeat on opposite side of building.

NOTE

On items 3, 4, 5 & 6, using the six holes in the beef up beam as a guide, with a 7/32" diameter drill bit, drill through the six holes (where needed), and fasten beams together using six bolts and nuts.

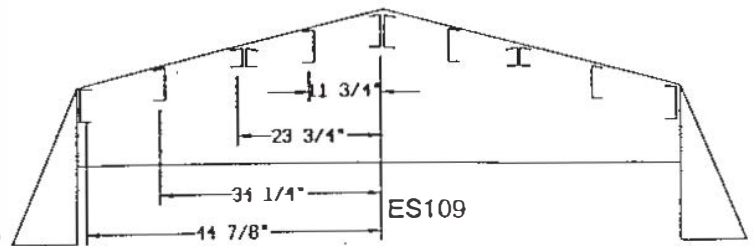
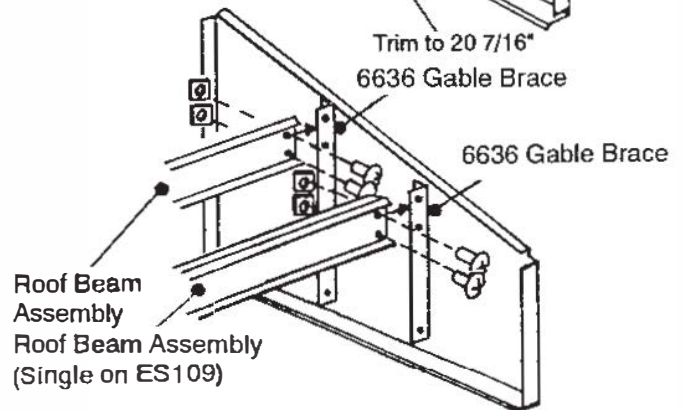
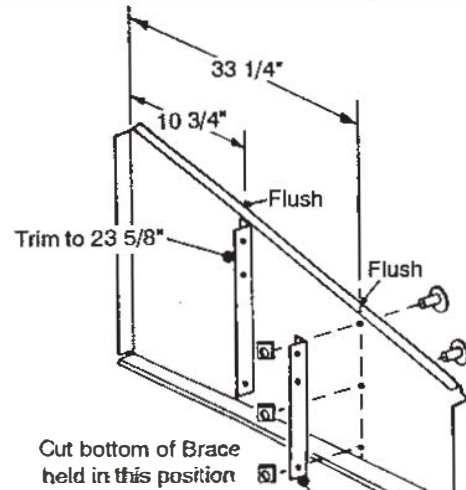

POSITION OF (8) 4" BEAMS & (4) 2" BEAMS

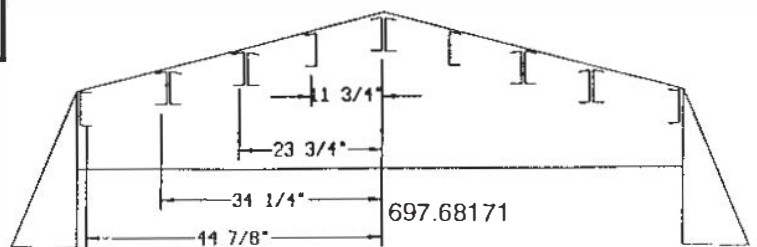

POSITION OF (14) 4" BEAMS

RBK10610

697.68207

Roof Panel Installation

NOTE

Each screw and bolt in the roof requires a washer

If your building has already been constructed and you had to remove the roof panels, use the larger #10Ax1/2" screws to replace the #8Ax5/16" screws that were removed

1 Install right roof panel at right rear corner of the building. Fasten this right roof panel to the beams as shown in the standard assembly instructions.

2 Using a 3/32" diameter drill bit, drill a hole through the roof panel and into the additional roof beams. Fasten the roof panel to the roof beams in these new holes using a screw and washer.

3 Install the remainder of the roof panels as outlined in the Steps of the standard assembly instructions for this building with the following exception.

NOTE

As described in item #2 of this step you *must* drill 3/32" diameter hole and fasten with screw and washer to the additional roof beams as shown.

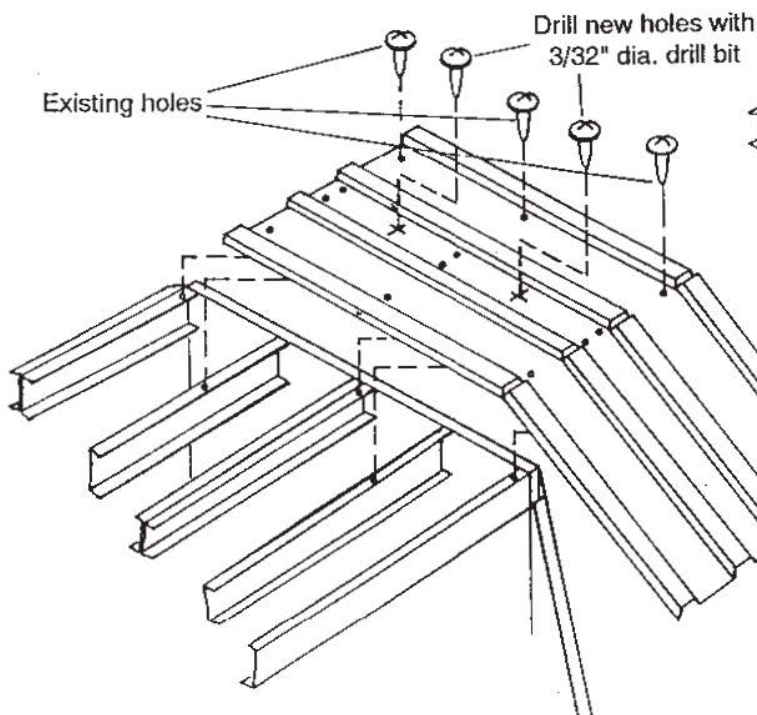
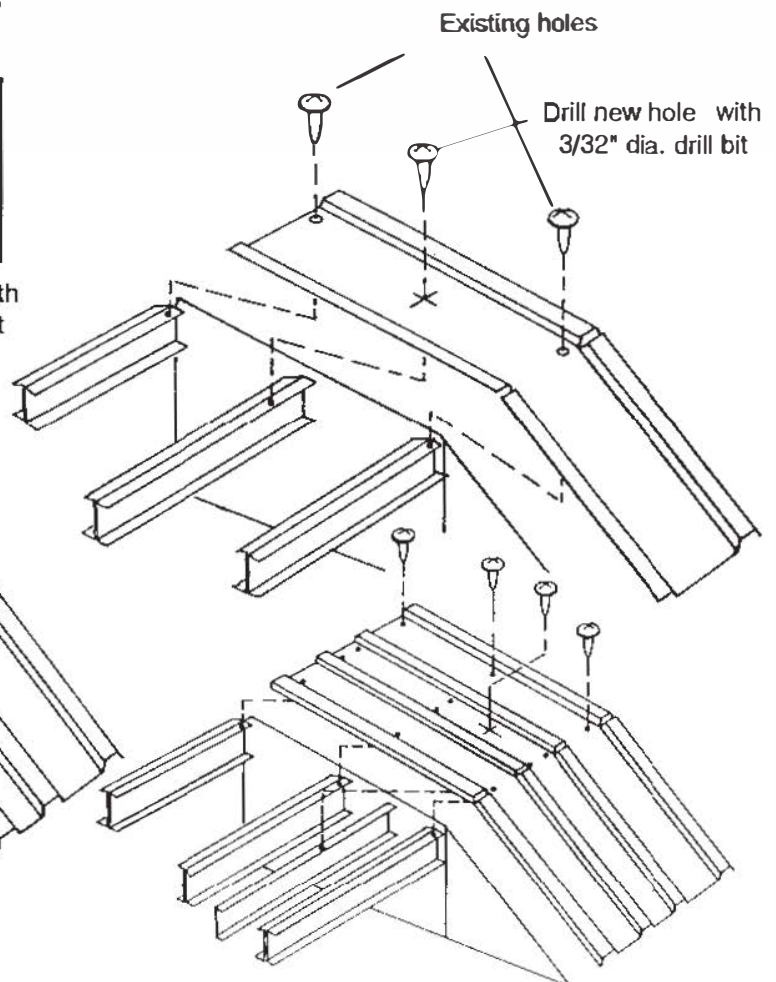
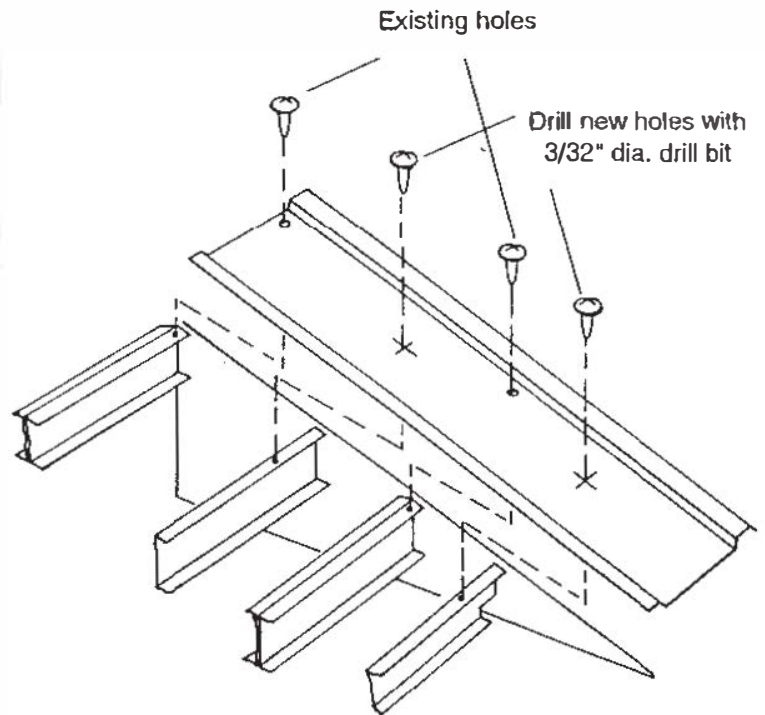

RBK1012

● Parts Needed For ● Roof Beam Installation

- 6636 Gable Brace (8)
- 9737 Roof Beam (6)

NOTE

This step to be done in conjunction with Steps for Gables/Braces and Roof Beams in the standard assembly instructions for your building. The roof beams packed with the standard building and additional roof beams packed with this kit must be used, to accomplish installation.

REMINDER

If your building has already been constructed, at this point you must remove roof panels.

- 1 On the 10x12 Low 9" Gable, install gables as shown.
- 2 Position **gable brace** 16" and 45 1/2" over from the main center roof beam on inside of the gable with leg pointing toward the center of the building. Cut gable brace to appropriate dimension shown, using tin snips. Mark two holes and with a 7/32" diameter drill bit, drill two holes into face of the gable. Fasten gable brace to the gable using two bolts and nuts. See diagram.

NOTE

Repeat item #2 on the other three gables.

- 3 Attach two **beef up roof beams**, back-to-back, to the center gable braces, as shown in the assembly instructions for your building, using bolts and nuts. Bolt the two beams together at six places, using bolts and nuts.
- 4 Fasten **beef up roof beam** to the **gable brace** (at 16"), using bolts and nuts. Position **beef up roof beam** back-to-back, with the roof beam from the standard building as outlined in the assembly instructions for your building. Use bolts and nuts to fasten the roof beams to the legs of the roof beam brackets. Repeat on other side. Bolt the two beams together at six places, and reverse.
- 5 Fasten standard roof beam to the **gable brace** (at 45 1/2"), using bolts and nuts. Repeat on other side. Notch end of beam at this location, using tin snips.

- 1 On the 10x12 High 17 1/2" Gable, follow Steps #1 through #5 above with the following exception. Position **gable brace** 13 3/4" and 43 1/4" over from the center of gable assembly on inside of the gable with leg pointing toward the center of the building. Mark three holes and with a 7/32" diameter drill bit, drill three holes into face of gable. Fasten gable brace to the gable using three bolts and nuts.

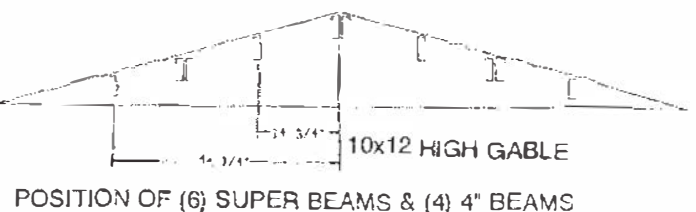
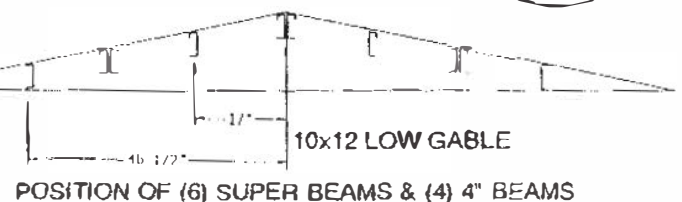
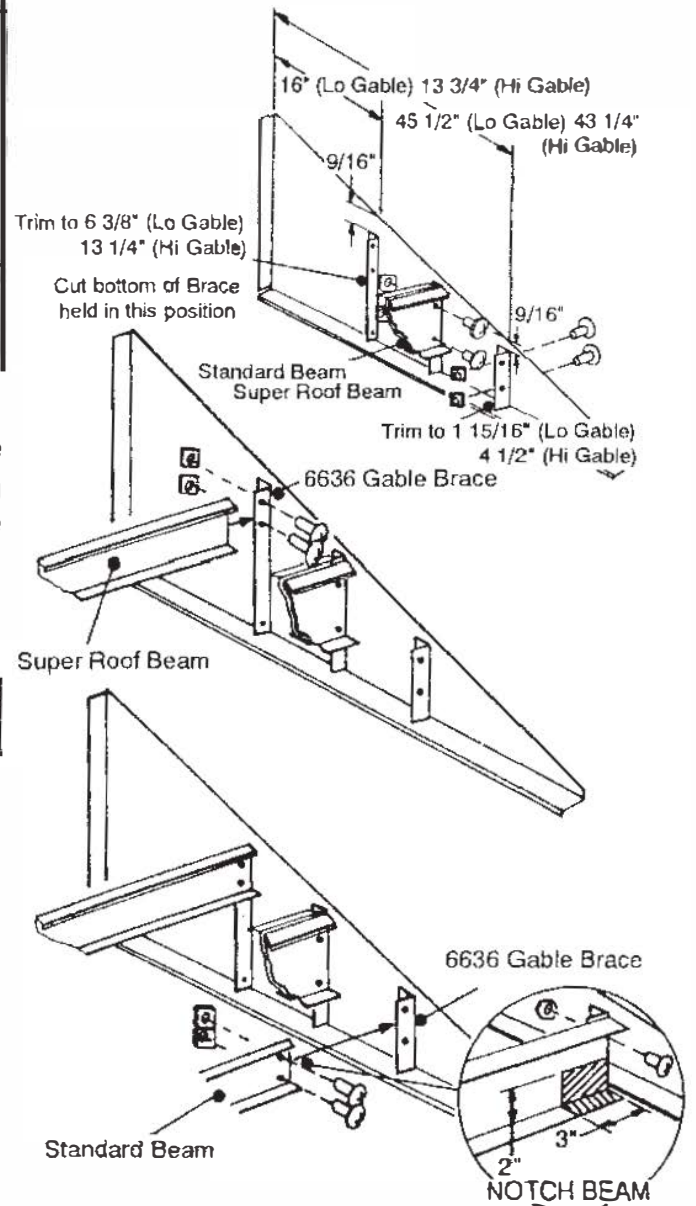

RBK1012

Roof Panel Installation

NOTE

Each screw and bolt in the roof requires a washer

NOTE

If your building has already been constructed and you had to remove the roof panels, use the larger #10x1/2" screws to replace the #8x5/16" screws that were removed

1 Using the Roof Step in the standard assembly instructions as a guideline, position a right roof panel at the back right corner of the building.

2 Fasten this right roof panel to the main roof beam assembly (labeled #1 in the diagram), and to the double roof beam (labeled #2 in the diagram), using screws and washers.

3 Using a 3/32" diameter drill bit, drill a hole through the roof panel and into the roof beam (labeled #3 & #4 in the diagram). Fasten the roof panel to the roof beams in these new holes using a screw and washer.

4 Install the remainder of the roof panels as outlined in the Steps of the standard assembly instructions for this building with the following exception.

NOTE

As described in Item #3 of this step you *must* drill 3/32" diameter hole and fasten with screw and washer to the additional roof beams as shown.

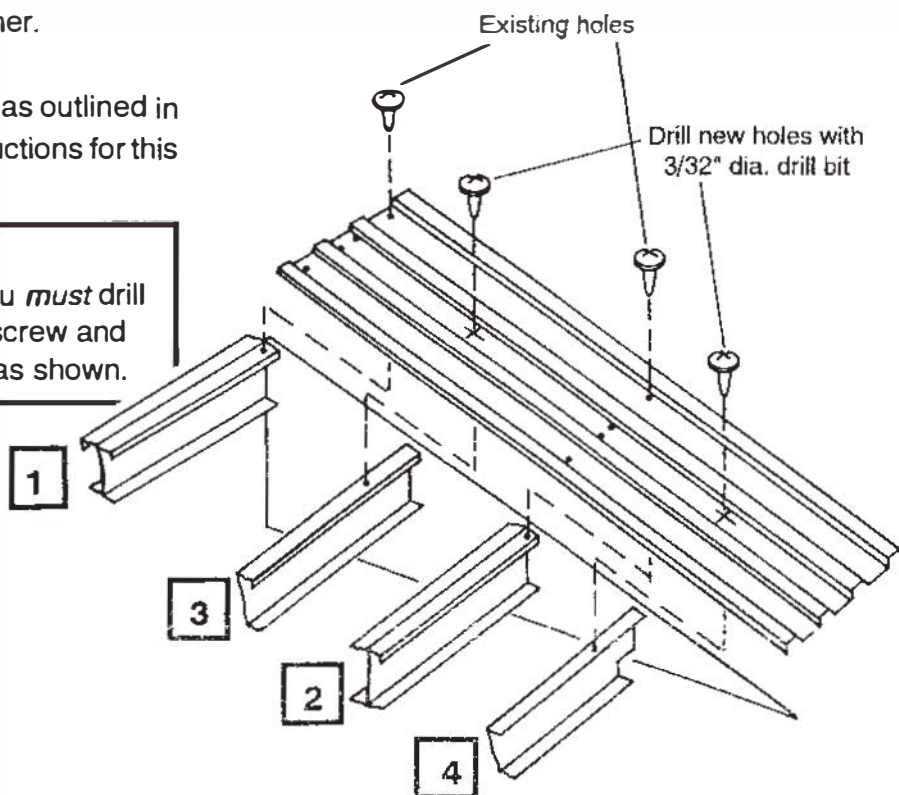

RBK1014

● Parts Needed For ● Roof Beam Installation

- 6636 Gable Brace (4)
- 6314 Roof Beam (6)

NOTE

The roof beams packed with the standard building and additional roof beams packed with this kit must be used, to accomplish installation.

REMINDER

If your building has already been constructed, at this point you must remove roof panels.

1 On the 10x13 & 10x14 High 24" Gambrel, install gables as outlined in the standard assembly instructions for your building.

2 Position **gable brace** 14 5/8" over from main center beam on inside of gables with leg pointing toward the center of the building. Mark three holes and with a 7/32" diameter drill bit, drill three holes into the face of the gable. Fasten gable brace to the gable using three bolts and nuts.

NOTE

Repeat item #2 on the other three gables.

3 Fasten two **beef up roof beams**, back-to-back, to the **gable brace**, using bolts and nuts. Repeat on opposite side of building. Bolt beams together at six places.

4 Position the remaining **beef up roof beams**, back-to-back, with the roof beam from the standard building as outlined in the assembly instructions for your building. Use bolts and nuts to fasten the roof beam to the legs of the roof beam brackets. Bolt beams together six places.

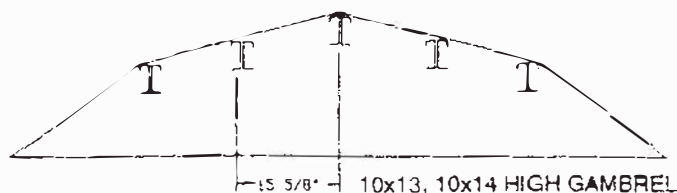
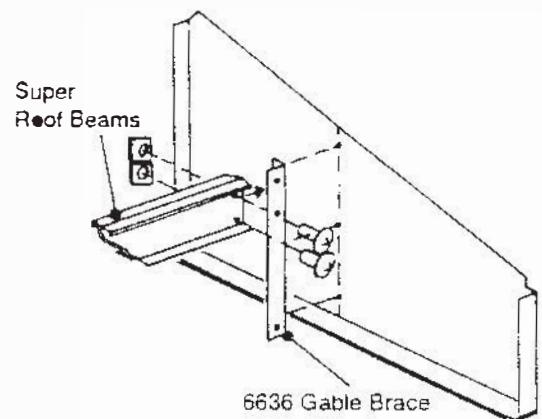
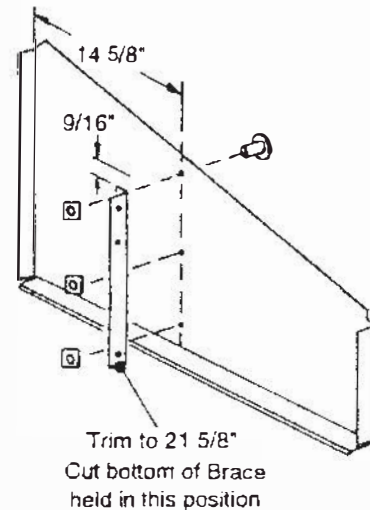

POSITION OF (10) SUPER BEAMS

RBK1014

● Parts Needed For ● Roof Beam Installation

- 6636 Gable Brace (8)
- 6314 Roof Beam (6)

1 On the ES1014 & 697.68172, install gables as outlined in the standard assembly instructions for your building.

2 Position **gable brace** 10 3/4" and 33 1/4" over from main center beam on inside of gables with leg pointing toward the center of the building. Mark three holes and with a 7/32" diameter drill bit, drill three holes into the face of the gable. Fasten gable brace to the gable using three bolts and nuts.

NOTE

Repeat item #2 on the other three gables.

3 On the ES1014, fasten single **beef up roof beams**, to the **gable braces**, using bolts and nuts. Repeat on opposite side of building.

4 On the ES1014, position the remaining **beef up roof beams**, back-to-back, with the roof beam from the standard building as outlined in the assembly instructions for your building. Use bolts and nuts to fasten the roof beam to the legs of the roof beam brackets. Bolt beams together at six places, using bolts and nuts.

5 On the 697.68172, fasten single **beef up roof beam** to the **gable brace** (at 10 3/4") using bolts and nuts. Repeat on opposite side.

6 On the 697.68172, position the remaining **beef up roof beams**, back-to-back, to the **gable brace** (at 33 1/4") using bolts and nuts. Repeat on opposite side of building. Bolt beams together, using 6 bolts and nuts.

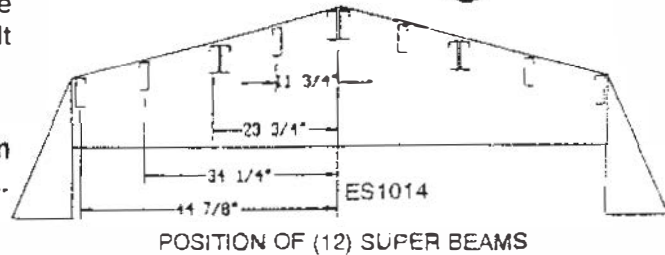
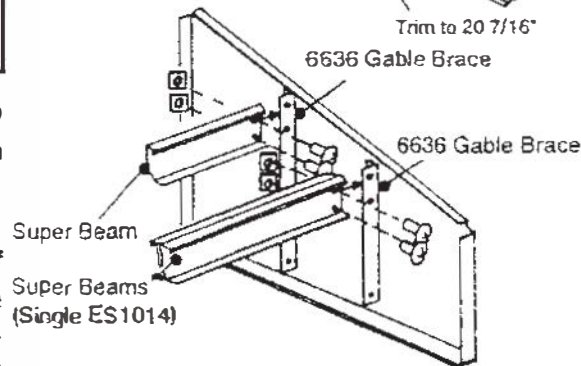
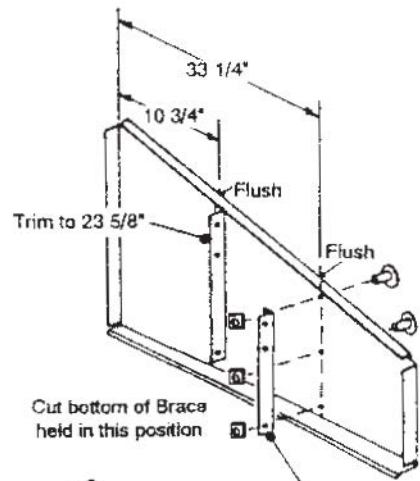

POSITION OF (12) SUPER BEAMS

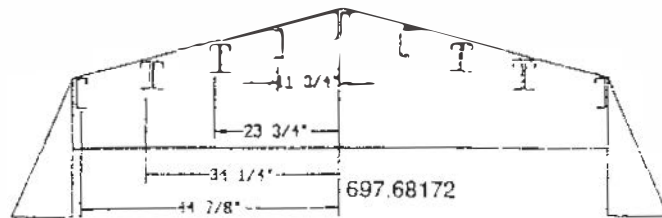

POSITION OF (14) SUPER BEAMS

RBK1014

Roof Panel Installation

NOTE

Each screw and bolt in the roof requires a washer

NOTE

If your building has already been constructed and you had to remove the roof panels, use the larger #10Ax1/2" screws to replace the #8Ax5/16" screws that were removed

1 Install right roof panel at right rear corner of the building. Fasten this right roof panel to the beams as shown the standard assembly instructions.

2 Using a 3/32" diameter drill bit, drill a hole through the roof panel and into the additional roof beams. Fasten the roof panel to the roof beams in these new holes using a screw and washer.

3 Install the remainder of the roof panels as outlined in the Steps of the standard assembly instructions for this building with the following exception.

NOTE

As described in item #2 of this step you *must* drill 3/32" diameter hole and fasten with screw and washer to the additional roof beams as shown.

