

Owner's Manual & Assembly Guide



! caution
sharp edges *

Gloves must be worn at all times to reduce risk of injury!

Model No.

- | | | | |
|---------------|--------------------------|------------------|--------------------------|
| EZ10872HVCR | <input type="checkbox"/> | EZ10872HVCREU | <input type="checkbox"/> |
| EZ10872HVCRCC | <input type="checkbox"/> | EZ10872HVCRCCCEU | <input type="checkbox"/> |
| EZ10872HVCC | <input type="checkbox"/> | EZ10872HVCCEU | <input type="checkbox"/> |
| EZ10872HVCCCR | <input type="checkbox"/> | EZ10872HVCCCREU | <input type="checkbox"/> |

10' x 8'

Nominal Size

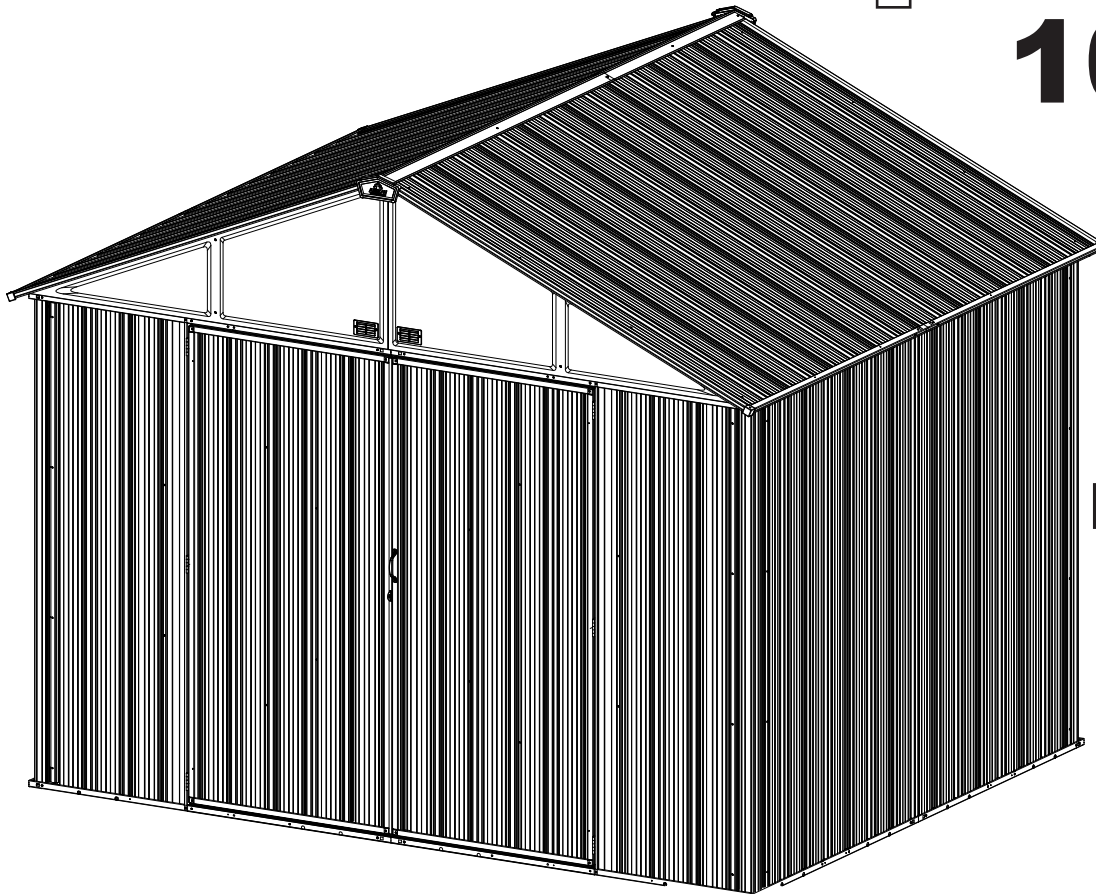

EZEE SHED™

Base Size	116 1/2" x 92 1/2" 295.9 cm x 235 cm
------------------	---

BUILDING DIMENSIONS

†Size rounded off to the nearest foot

For proper base construction see page 14

Approx.† Size	Storage Area	Exterior Dimensions (Roof Edge to Roof Edge)			Interior Dimensions (Wall to Wall)			Door Opening	
		Width	Depth	Height	Width	Depth	Height	Width	Height
10' x 8'	71 Sq. Ft. 502 Cu. Ft.	117 3/4"	98"	98"	114"	90"	97"	63 1/2"	69 3/4"
2,9 m x 2,3 m	6,6 m ² 14,2 m ³	299,1 cm	248,9 cm	248,9 cm	289,6 cm	228,6 cm	246,4 cm	161,3 cm	177,2 cm

* See Inside for Detailed Safety Information.

SAFETY PRECAUTIONS...

Safety precautions MUST be followed at all times throughout the construction of your building!

sharp edges

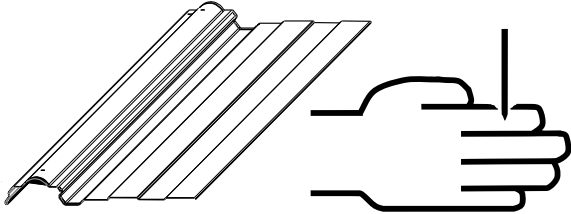

Care must be taken when handling various pieces of your building since many contain sharp edges. Please wear work gloves, eye protection and long sleeves when assembling or performing any maintenance on your building.

always practice proper tool safety

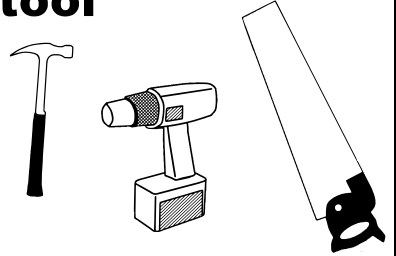

Practice caution with the tools being used in the assembly of this building. Be especially familiar with the operation of all power tools.

no children or pets at worksite



Keep children and pets away from the worksite during construction and until the building is completely assembled. This will help avoid distractions and any accidents which may occur.

don't focus weight on roof



NEVER concentrate your weight on the roof of the building. When using a step ladder make sure that it is fully open and on even ground before climbing on it.

beware of wind



Do NOT attempt to assemble your building on a windy day. The large panels can catch the wind like a "sail", causing them to be whipped around making construction difficult and unsafe.

Do NOT attempt to assemble your building before double checking that you have all the parts indicated in the parts lists (page 9) as well as all hardware (page 8). Any building left partially assembled may be seriously damaged by even light winds.

IMPORTANT NOTE ON ANCHORING

- Your building MUST be anchored to prevent wind damage. An anchoring kit is not supplied with your building and you have many options when it comes to anchoring. See anchoring page for more info.
- You must also have a temporary anchoring system in place in case you need to take a break from assembly. See page 4 for more info.

ASSEMBLY TIPS & TOOLS

Watch the Weather Closely: Be sure the day you choose to install your building is dry and calm. Do **NOT** attempt to assemble your building on a windy day. Be careful on wet or muddy ground.

Use Teamwork: Two or more people are required to assemble your building. One person can hold the parts or panels in place while the other person fastens them together and handles the tools. This makes the process of assembling your building faster and safer.

Tools and Materials: Here is a list of some basic tools and materials you will need to assemble your building. Decide which method of anchoring and the type of base you will use to make a complete list of the materials you will need.

WHAT YOU NEED

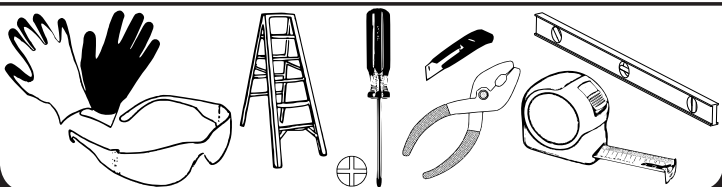

- Work Gloves
- Safety Glasses
- Step Ladder
- No. 2 Phillips Screwdriver (Magnetic Tip Preferred)
- Utility Knife or Scissors
- Pliers
- Carpenter's Level
- Tape Measure

RECOMMENDED TIME SAVERS

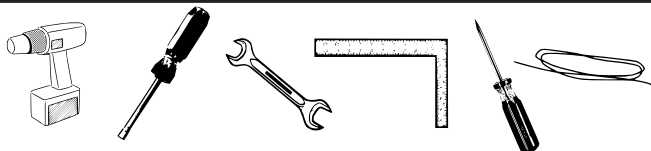

- Power Drill (Cordless, Variable Speed)
- Nut Driver or Wrench
- Square
- String (for squaring the frame)
- Awl (to align holes)

BASE PREPARATION TOOLS

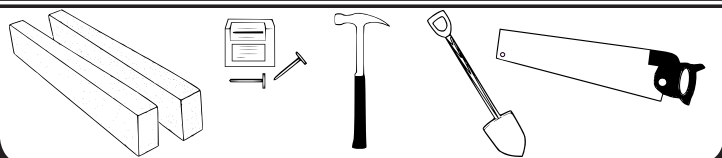

- Lumber and/or Concrete
- Hammer and Nails
- Spade or Shovel
- Hand Saw or Power Saw

How to Select and Prepare Your Building Site: Before you start to assemble your building, you will want to decide on a good location. The best location is a level area with good drainage.

- Allow enough working space so it is not difficult to move parts into position for assembly. Be sure there will be enough space at the entrance for the doors to completely open. Also, there needs to be enough space outside the building to be able to fasten the panel screws from the outside.
- Before assembling any parts, your base should be constructed and an anchoring system should be ready to use.

FREQUENTLY ASKED QUESTIONS

Q. How long will it take to assemble the building?

A. Assembly time depends on a variety of factors, including roof design, tools available, DIY skill and the pace at which you work. Guidelines for each shed assembly are approximate AFTER completion of the base, and assume two or more people working on the assembly. Generally, you should plan on at least one day working with someone who can assist you; again, after constructing the base. Refer to the clock icons on each product page on the website for specific time estimates.

Q. How do I decide where to put my shed?

A. The key to a successful assembly is to make sure the shed will be square and level when built. The shed can be assembled directly onto level ground (grass or dirt). If you have location options, choose one that is already flat, with good drainage to control moisture. If you don't have a flat, well-drained area, you need to prepare the space. Level the area using cinder blocks, concrete, crushed gravel or other sturdy materials. Once level with good drainage, construct your base. Using a carpenter's level, make sure your base is level and free of bumps or ridges to provide good support for your building.

Q. What if I can't finish my building in one session?

A. If weather conditions change so that it becomes windy or rainy, it is recommended that you stop assembly until conditions improve. This is for your safety and for protection of the shed. However, do not leave your unfinished construction without first temporarily anchoring the walls of the shed and placing weights, such as patio blocks or sandbags, around the walls. Failure to anchor the building if you leave it while partially assembled could result in irreparable damage or personal injury if the building collapses.

Q. Do I need to anchor my building?

A. Yes! Fully assembled buildings should be anchored using a permanent anchoring system. If you need to leave your building before it is completely assembled, you will need to place weights, such as patio blocks or sandbags, around the floor channel.

Q. How do I temporarily anchor my building before it's fully assembled?

A. An incomplete building must be anchored before breaking for any period of time to prevent possible damage.

- If the building is on a wood base, secure the frame with wood screws in the corners
- If the building is on a concrete base, temporarily anchor the frame in the corners
- Use patio blocks or sandbags along side of the floor channel as weights
- Secure the floor channel to the ground with ground augers or rope the frame in the corners to the ground

Q. How do I control condensation and prevent water from leaking in?

A. To minimize condensation, install a continuous, unbroken plastic vapor barrier with a thickness of 6 mil. between exposed ground surface and the building's base. Make sure that washers are used throughout the assembly process. Ensure that all washers are flush with the panels and do not over-tighten screws, as this can crack the washers. Silicone caulking may be used to create watertight seals at the washers and throughout the building.

Q. What kind of base do I use?

A. You can:

- Pour a concrete slab
- Build a wood deck/floor (use exterior-grade plywood)
- Use patio blocks
- Build on crushed gravel, dirt or grass

If you are building a wood deck/floor, an Arrow floor frame kit on top of your deck/floor assembles in minutes and provides a floor frame suitable for a 5/8" exterior-grade plywood floor (not included). A continuous unbroken plastic vapor barrier with a thickness of 6 mil. between the ground and the building's base is also recommended.

Q. How should I measure for my base?

A. Shed dimensions are provided in "nominal" size. Nominal sizes are roof-edge measurements rounded to the nearest foot and are not the measurements to use for constructing the shed base. So, carefully check the exact, recommended base size in the specifications for your shed model.

Note: If you have to stop assembly for any reason before it is complete, do not leave your unfinished construction without first temporarily anchoring the corners of the shed to your base and placing weights, such as patio blocks or sandbags, along side the floor channels.

Q. Can the building be painted?

A. The buildings can be painted with an exterior-grade paint designed for use on steel. Contact your local paint supplier for recommendations.

Q. I heard that rust might be an issue with steel; is it?

A. While bare steel can rust, with proper care this should not be an issue. For a long-lasting finish, periodically clean the exterior surface and apply spray-on car wax. Touch up scratches as soon as you notice them by immediately cleaning the area with a wire brush or emery paper, washing it and applying touch-up paint. This will minimize rust and maintain your shed's attractive appearance for years.

Q. How do I take care of dents in my shed?

A. Proper selection of shed size, including a sufficient door-opening width, and proper placement of your shed should minimize the possibility of damage. If a dent does occur, carefully push the dent out from the opposite side. If the paint has been scratched or removed, touch up the area as soon as you notice it. Immediately clean the area with a wire brush or emery paper, wash it and apply touch-up paint. This will minimize rust and maintain your shed's attractive appearance for years.

PANEL & CHANNEL ASSEMBLY TIPS

PANEL

1. Recommend a large table or sawhorses with plywood for working surface.
2. Corners will need to hang off of work surface, so an elevated flat surface is important.
3. Arrows always point up, and always get covered.
4. Start from middle and work your way out to push together panels.
5. Panels can be pulled apart if not aligned properly. Once channels are applied, the wall assembly will be “final”.

CHANNEL

6. Work from one end and angle the channel. Line up a section and then tap the channel to work it into place. Continue working your way down the channel.

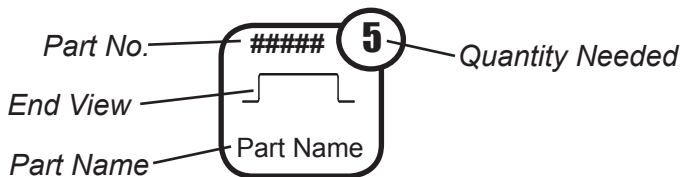

At the top of each page you will see one or more **Part Cues** like the one to the left. These **Part Cues** are designed to help you quickly identify the parts needed for each step.

Confirm that all hardware and parts are present before attempting to assemble your building.

For missing or damaged parts contact Customer Service. Do not return to store.

Part Numbers

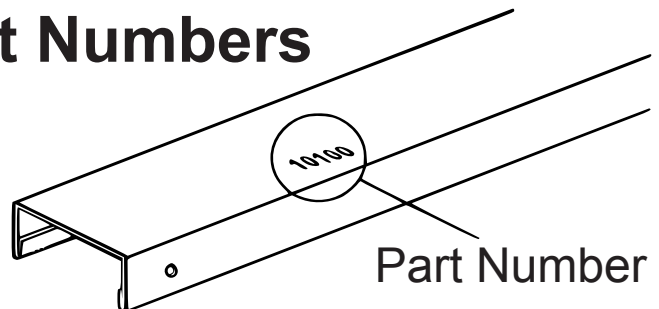

1. Each part has an identifying part number on it.
2. Part Numbers are referenced in each step.
3. Unpainted parts have a stamped in number and painted parts have a number that is inked on.

Remove inked on numbers with soap and water after assembly.

CARE & MAINTENANCE...

Exterior Care:

For a long lasting finish, clean and wax the exterior surface. We recommend washing with a mild soap solution. DO NOT use power washing to clean your shed. Using a spray automotive type wax periodically on the exterior is highly recommended if you are in a high humidity or coastal climate region.

Combustibles and corrosives must be stored in air tight containers designed for chemical and/or combustible storage. Corrosive chemicals such as fertilizers, pesticides and herbicides should be cleaned off the interior and exterior surfaces immediately. Rust caused by chemical damage is not covered by the warranty.

DO NOT STORE POOL CHEMICALS IN YOUR SHED - THIS VOIDS YOUR WARRANTY

Rust protection precautions may help to stop rust from developing, or stop it quickly as soon as it appears.

- Avoid nicking or scraping the coating surface, inside and out.
- Keep roof, base perimeter and door free of debris and leaves which may accumulate and retain moisture. These can do double damage since they give off acid as they decay.
- Touch up scrapes or nicks and any area of visible rust as soon as possible. Make sure the surface is free of moisture, oils, dirt or grime and then apply an even film of high quality touch-up paint.
- Various paint manufacturers provide products for rust treatment and coverage. If surface rust does appear on your shed we recommend treating those areas as soon as possible, following the paint supplier of your choice instructions.
- Our customer service department can provide the paint tinting formula for matching the color of your shed. We also have touch-up paint available for repairing small nicks and scratches.

Roof:

Keep the roof clear of leaves and snow. Heavy amounts of snow on the roof can damage the building making it unsafe to enter.

Fasteners:

Use all washers supplied to protect against weather infiltration and to protect the metal from being scratched by the screws. Regularly check screws, bolts, nuts, etc., and retighten as necessary.

General:

- A plastic sheet (vapor barrier) placed under the entire floor area may reduce condensation.
- Wash off inked part numbers on coated panels with soap and water.
- Silicone caulking may be used for watertight seals throughout the building.

Please note, Manufacturer cannot be held responsible for any consequences due to buildings that are not installed per these instructions, or for damage due to weather conditions or acts of God.

Keep these assembly instructions and owner's manual for future reference.

HARDWARE LIST...

Hardware Views by Key No.

Key No.	Part No.	Part Description	Qty.	✓ List
1	65923	Bolt (#8-32 x 3/8) (10 mm)	84	
2	65103	Hex Nut (#8-32)	84	
3	65004	Screw (#8AB x 5/16) (8 mm)	226	
4	66646	Washer Sheet	4	
5	66715	Door Handle	1	
6	66718	Hinge	6	
7	66720	Padlock Eyelet	1	
8	60H	Corner Cap	4	
9	66860	Peak Cap	2	
10	66847	Vent Gable	4	
11	66719	Spring Pin Upper	1	
12	66713	Spring Pin Lower	1	
13	66721	U-Nut (Door Clip)	12	
14	10280	Corner Clip	8	
15	66866	Door Closure Clip	2	

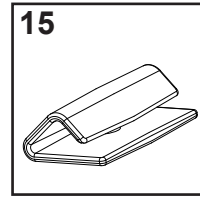
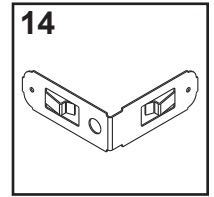
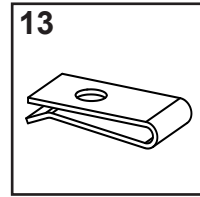
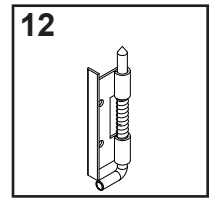
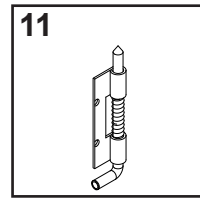
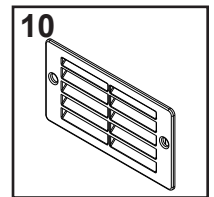
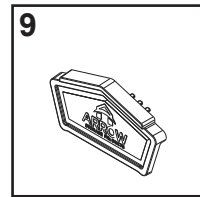
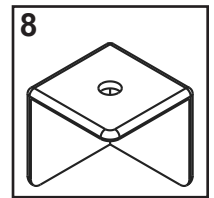
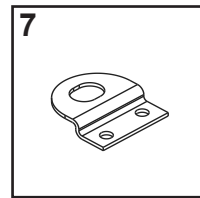
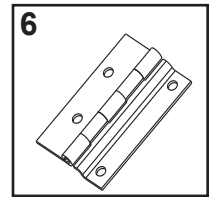
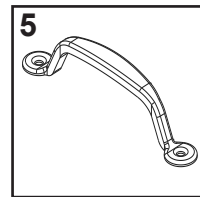
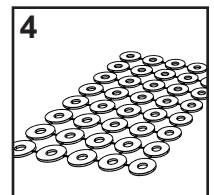
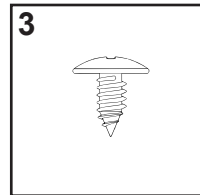
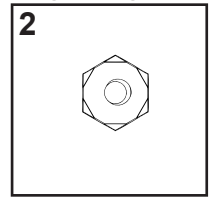
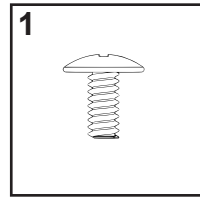

The fasteners used in each step are shown actual size at the top of each page. If you are unsure which fastener to use, hold it up to the picture and use the one that matches.

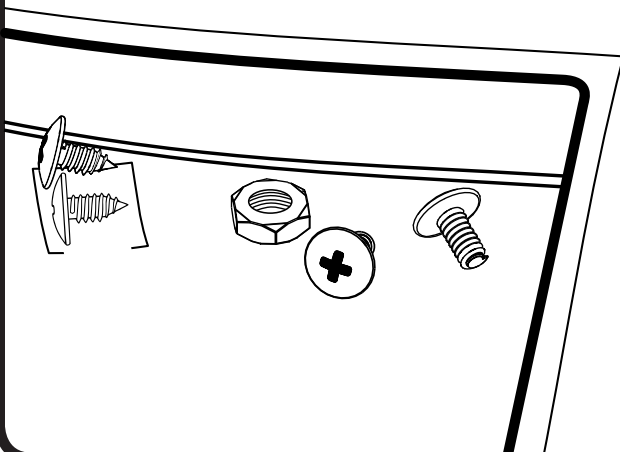

PARTS LIST...

Key No.	Part No.	Part Description	Qty.	✓ List
1	11035	Floor Channel (unpainted)	4	
2	11034	Ramp (unpainted)	1	
3	10275	Door Brace Horizontal (painted)	4	
4	11017	Door Brace Vertical (painted)	2	
5	11027	Door Brace Vertical (painted)	1	
6	11024	Door Jamb	2	
7	10288	Door Brace Diagonal	4	
8	10336	Roof Channel (painted)	4	
9	11033	Header Trim (painted)	1	
10	11037	Wall Channel (painted)	4	
11	10340	Floor Channel (unpainted)	4	
12	11038	Ridge Beam	8	
13	11040	Roof Beam Bracket	4	
14	11030	Gable Brace	2	
15	10337	Roof Channel (painted)	4	
16	11039	Fascia Trim (painted)	4	
17	11022	Ridge Cap	1	
18	11041	Roof Beam Brace	2	
19	11008	Door Panel	2	
20	11009	Door Panel	2	
21	11032	Ridge Cap	1	
22	10999	Panel Wall	3	
23	11000	Corner Panel	4	
24	10998	Panel Wall	22	
25	11036	Gable Right	2	
26	80123	Gable Left	2	
27	11014	Roof Panel	12	
28	80121	Roof Panel Left	2	
29	11015	Roof Panel Right	2	
30	11019	Channel Splice	10	
31	10341	Wall Channel (painted)	4	
32	11026	Vertical Door Brace (painted)	1	
33	11025	Door Astragal	1	
34	11031	Header Angle	1	
35	11004	Panel Wall	2	
36	11002	Door Panel	2	
37	11028	Channel Splice	2	

Selected End Views by Key No.

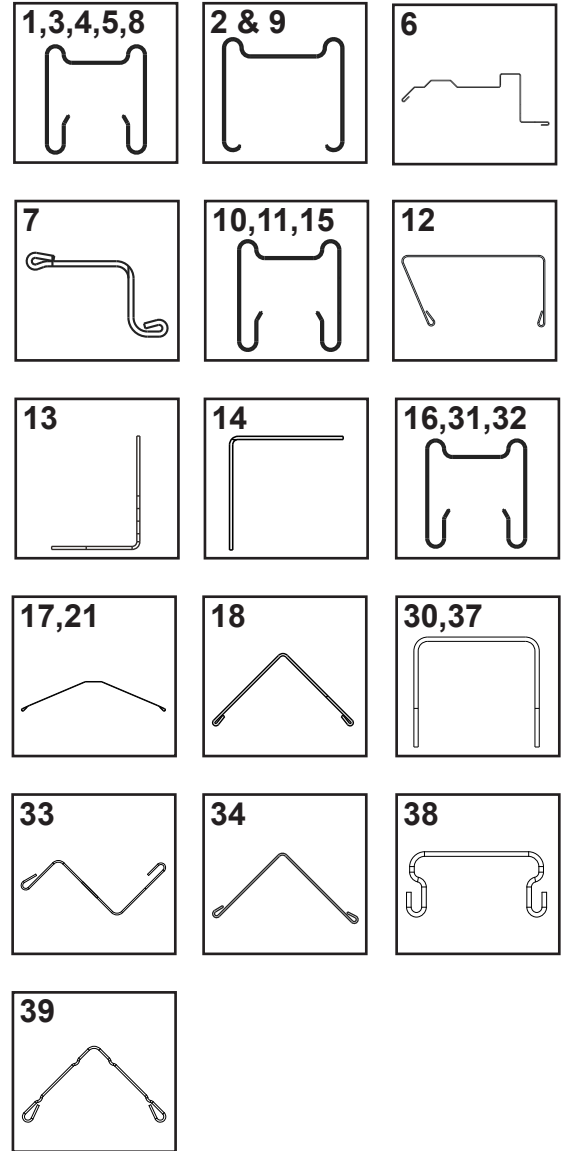

38	11051	Roof Beam Brace	4
39	11053	Door Jamb Support	2

ASSEMBLY BY KEY NO.

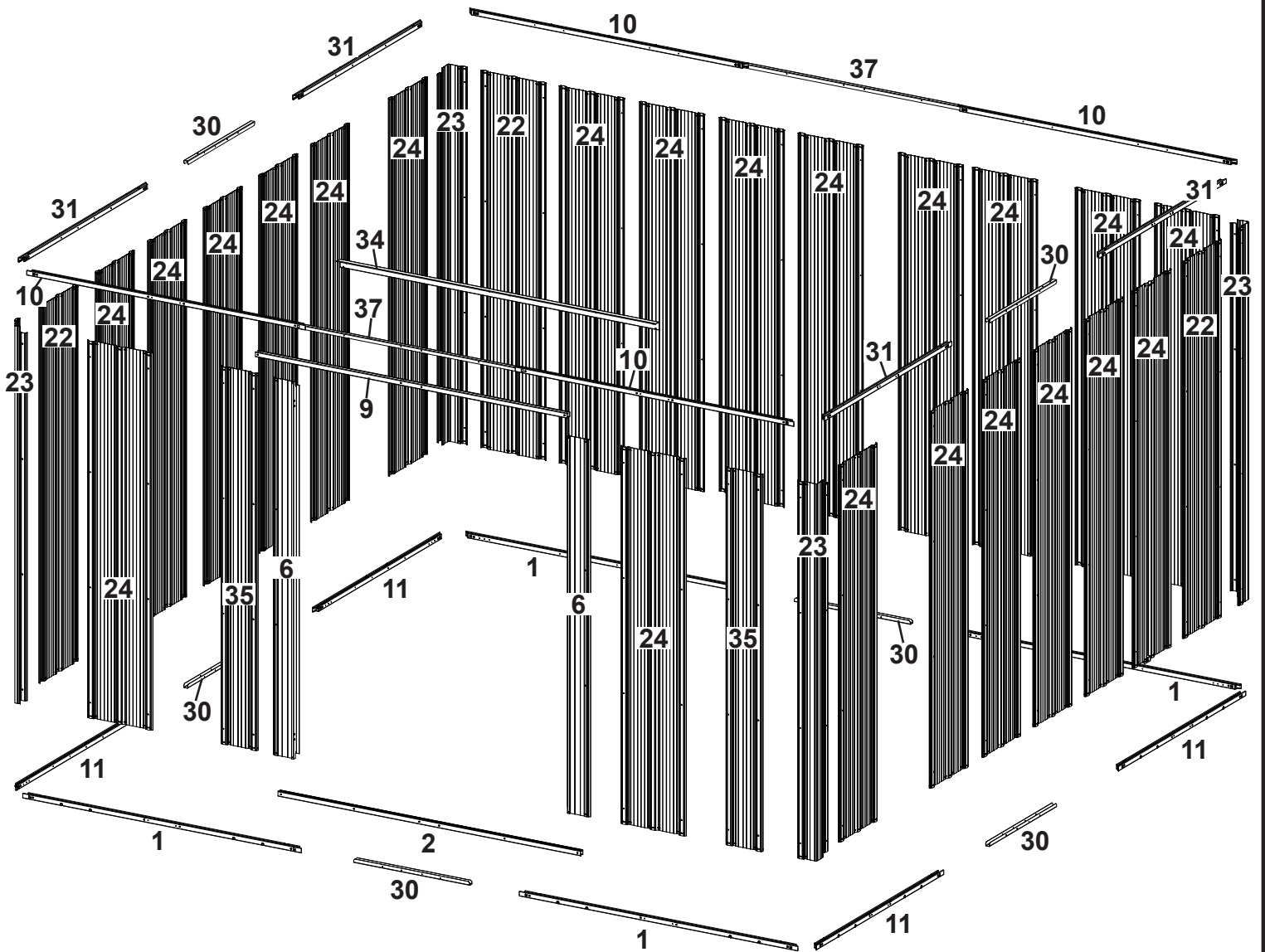

ASSEMBLY BY KEY NO.

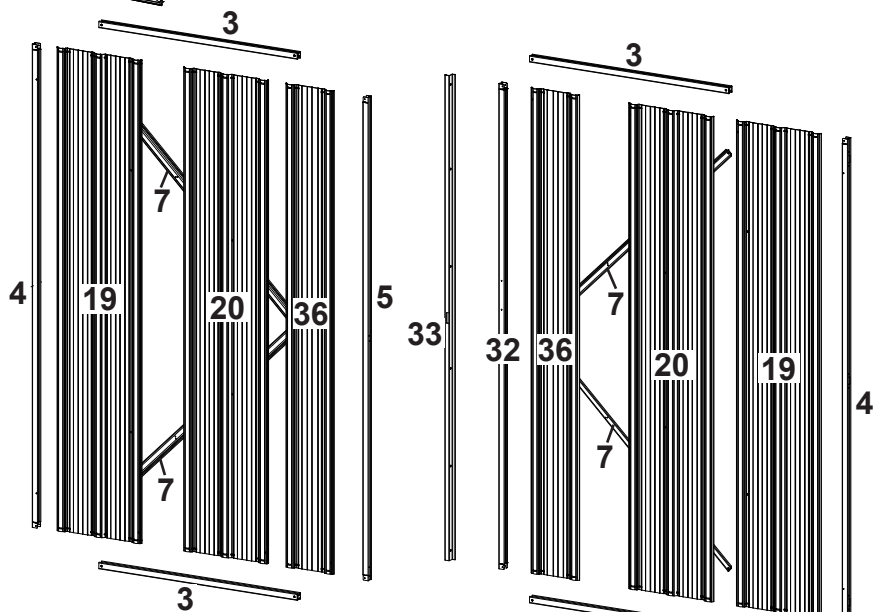
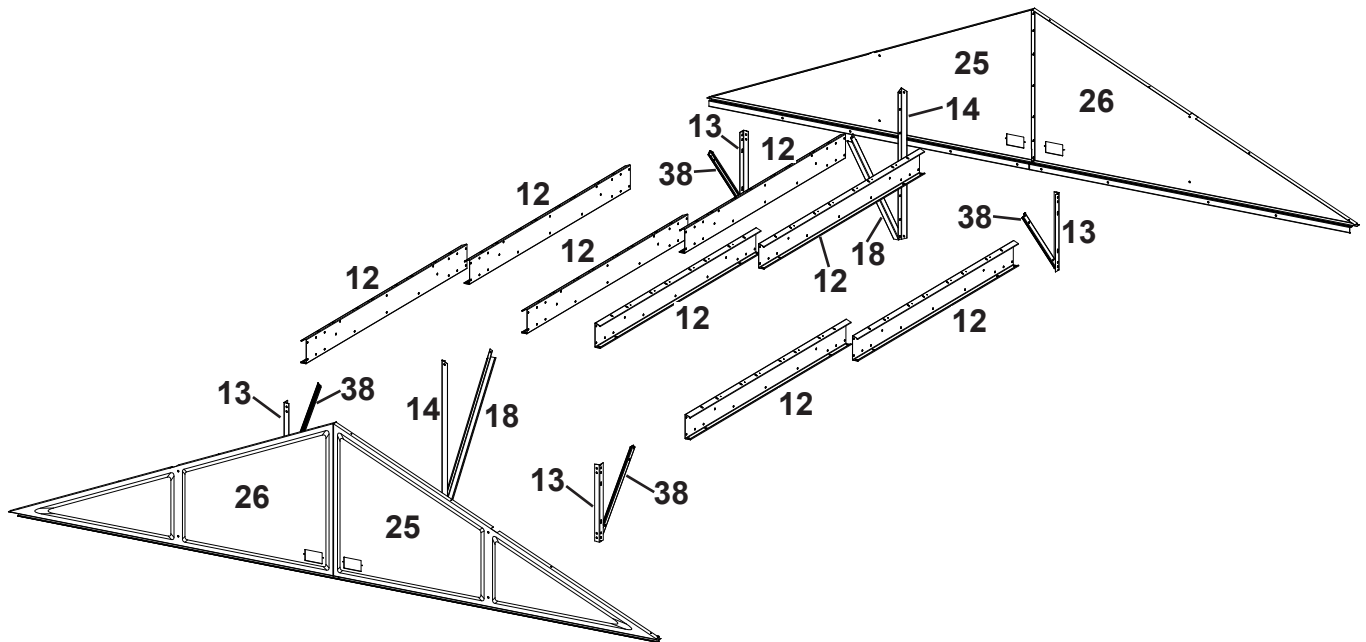
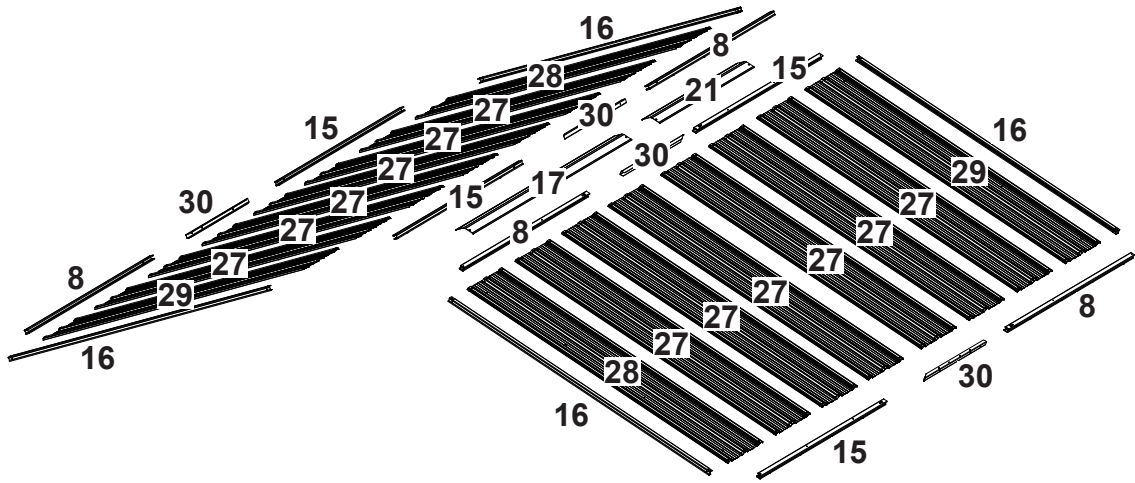

ASSEMBLY OVERVIEW

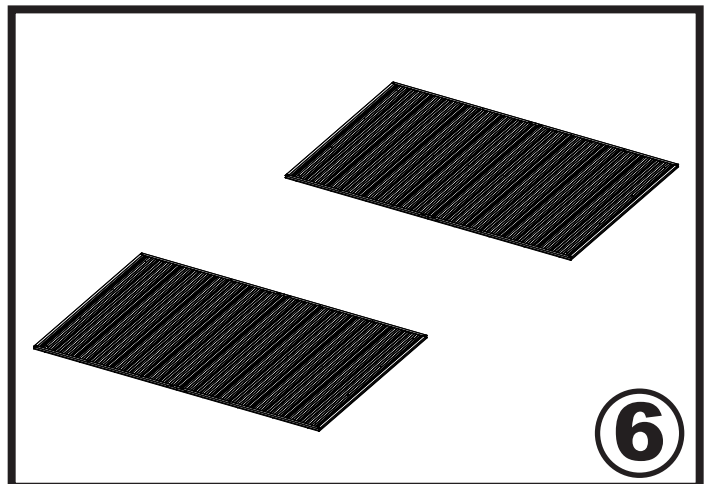
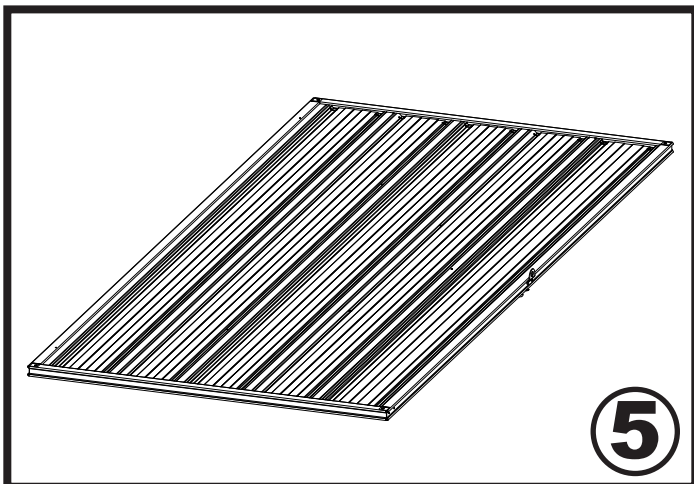
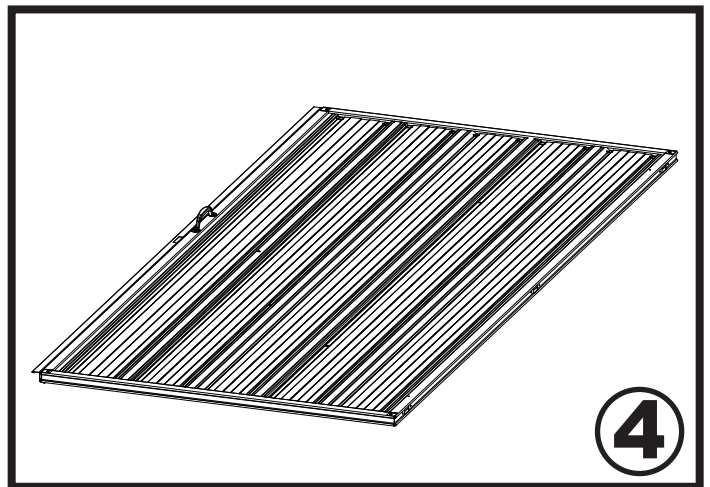
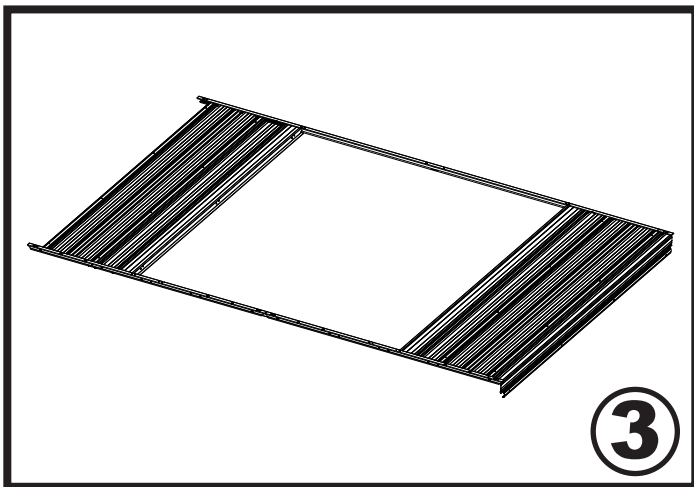
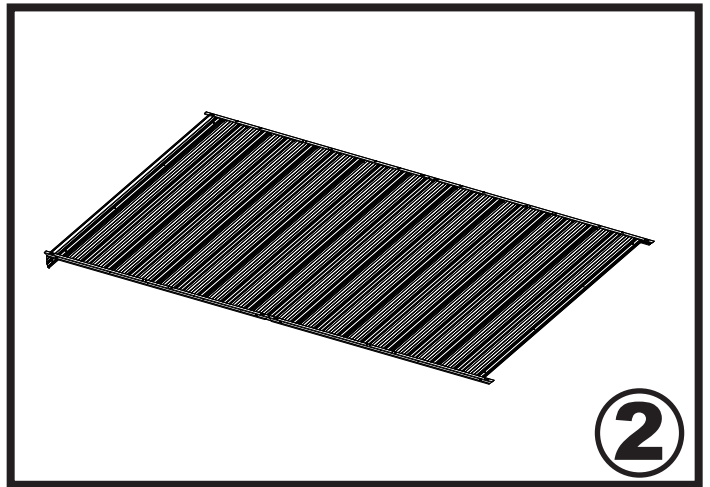
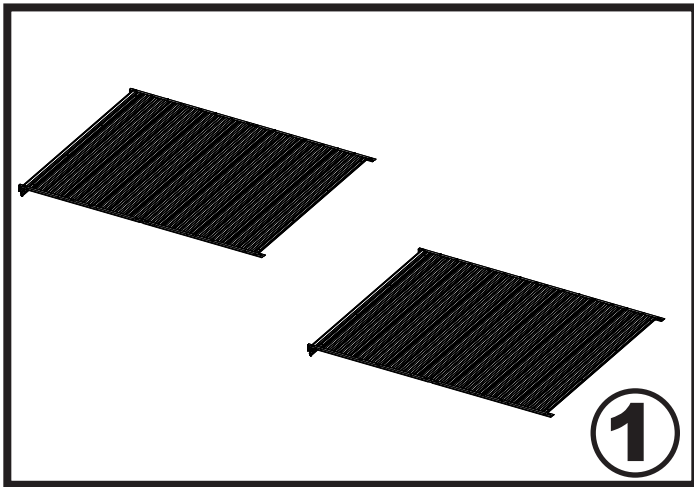

ASSEMBLY OVERVIEW

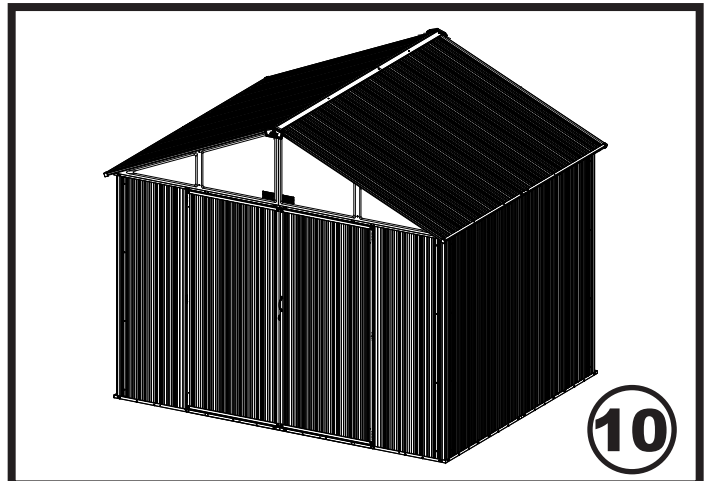
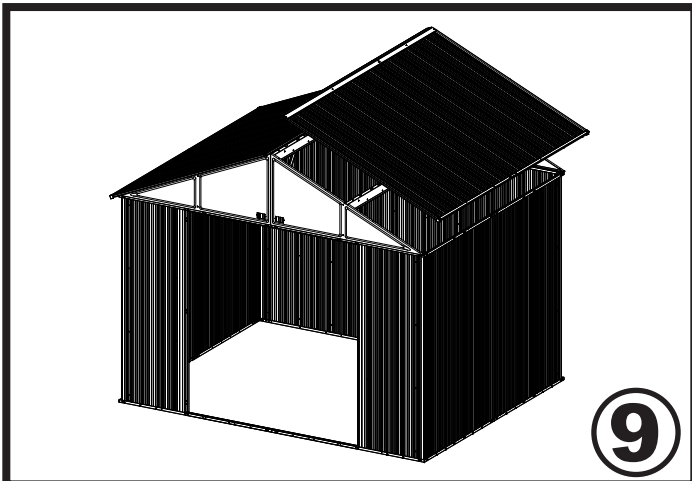
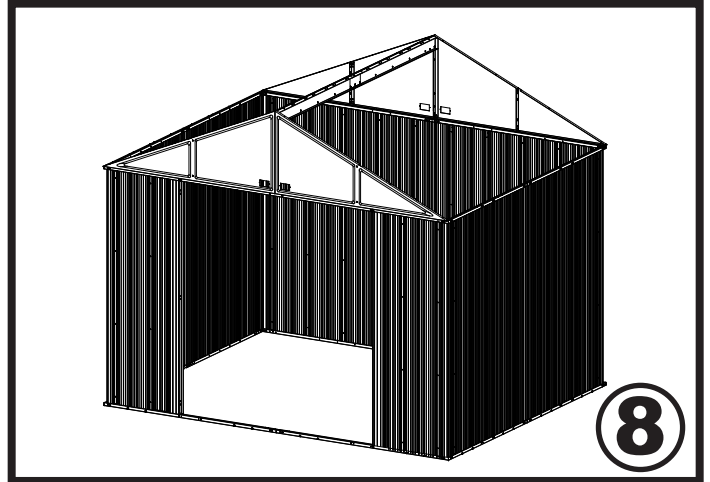
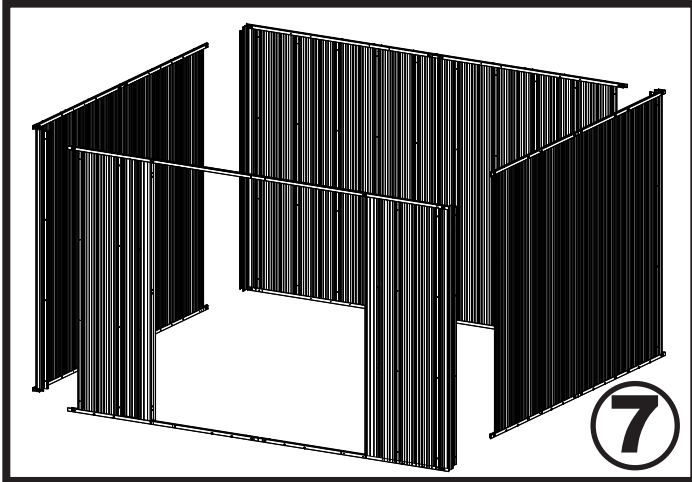

CONSTRUCTING A BASE...

OPTION 1: Directly on ground (earth)

Assemble your building directly on level ground (grass, dirt, rock, sand, etc.).

OPTION 2: Wood Platform

If you decide to build your own base, be sure to select the appropriate materials.

These are the recommended materials for your base:

- 2 x 4's (38 mm x 89 mm) Pressure Treated Lumber
- 5/8" (15,5 mm) 4 x 8 (1220 mm x 2440 mm) Plywood-exterior grade
- 10 & 4 penny Galvanized Nails
- Concrete Blocks (optional)

NOTE: Pressure Treated Lumber must not be used where it will make contact with your storage building. The properties of Pressure Treated Lumber will cause accelerated corrosion. **If Pressure Treated Lumber comes in contact with your storage building your warranty will be voided.**

The platform should be level and flat (free of bumps, ridges etc.) to provide good support for the building. The necessary materials may be obtained from your local lumber yard.

To construct the base follow instructions and diagram.

Construct frame (using 10 penny galvanized nails)

Measure 16"/24" (40,6 cm/61,0 cm) sections to construct inside frame (see diagram)

Secure plywood to frame (using 4 penny galvanized nails)

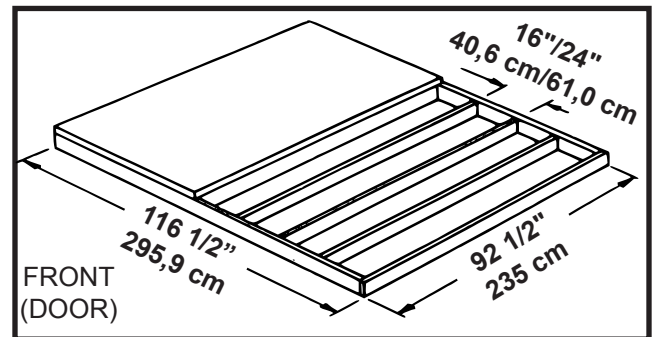

Note: Platform/Slab will extend 9/16" (1,4 cm) beyond floor frame on all four sides. Seal this 9/16" (1,4 cm) of wood with a roofing cement (not included), or bevel this 9/16" (1,4 cm) of concrete when pouring, for good water drainage.

OPTION 3: Concrete Slab

The slab should be at least 4" (10,2 cm) thick. It must be level and flat to provide good support for the frame.

The following are the recommended materials for your base.

- 1 x 4's (19 mm x 89 mm) (will be removed once the concrete cures)
- Concrete
- Sheet of 6 mil plastic
- We recommend for a proper strength concrete to use a mix of:
1 part cement • 3 parts pea sized gravel • 2 1/2 parts clean sand

Prepare the Site/Construct a Base

1. Dig a square, 6" (15,2 cm) deep into the ground (remove grass).
2. Fill up to 4" (10,2 cm) in the square with gravel and tamp firm.
3. Cover gravel with a sheet of 6 mil plastic.
4. Construct a wood frame using four planks of 1x4 (19 mm x 89 mm) lumber.
5. Pour in concrete to fill in the hole and the frame giving a total of 4" (10,2 cm) thick concrete. Be sure surface is level.

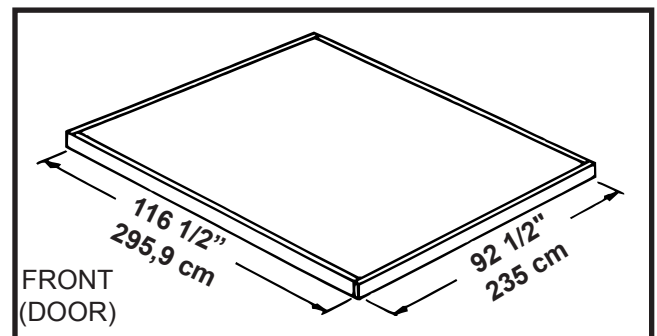

Note: Finished Slab dimensions, with lumber removed.

Step 1: Side Walls (2X)

You will need for this page:

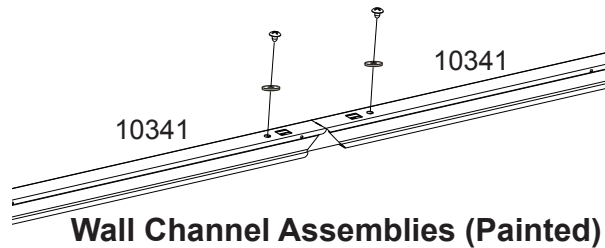
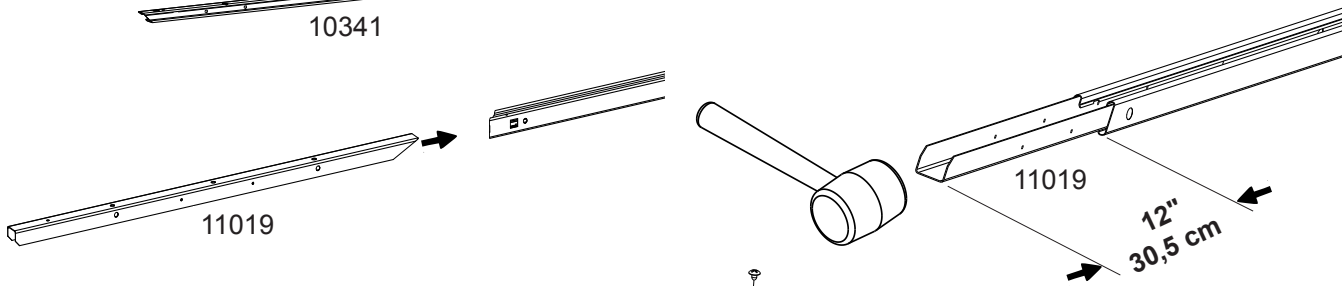
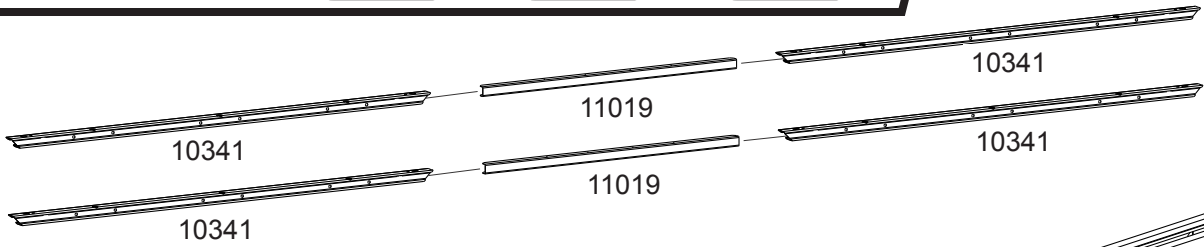
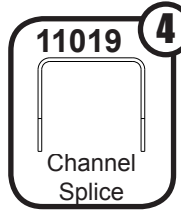
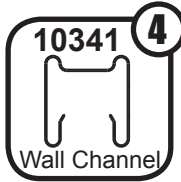
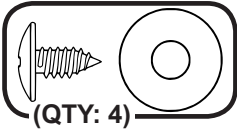

Wall Channel Assemblies (Painted)

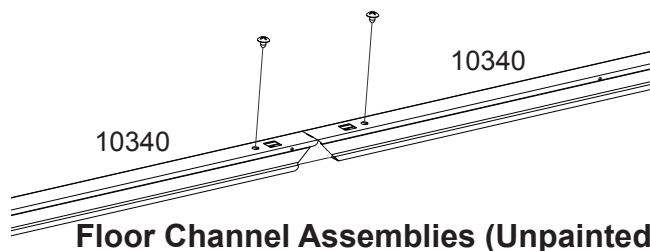
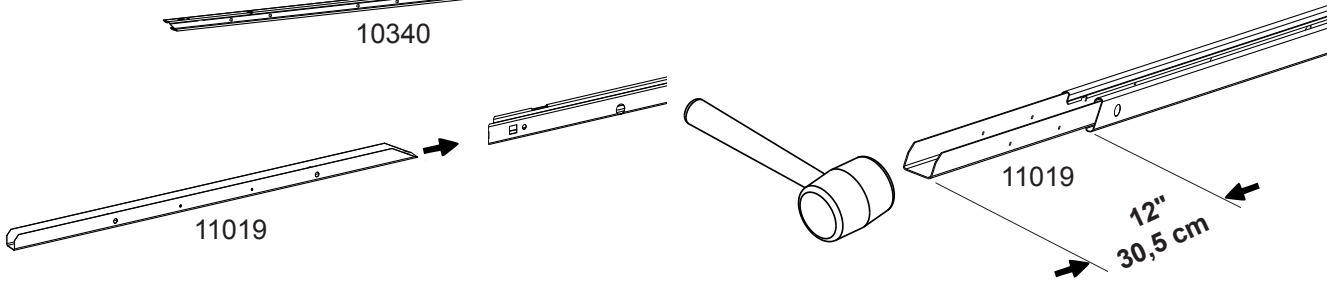
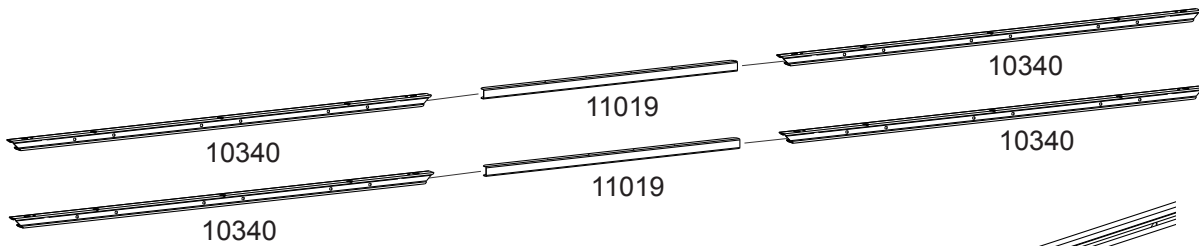

Floor Channel Assemblies (Unpainted)

Step 1: Side Walls (2X)

You will need for this page:

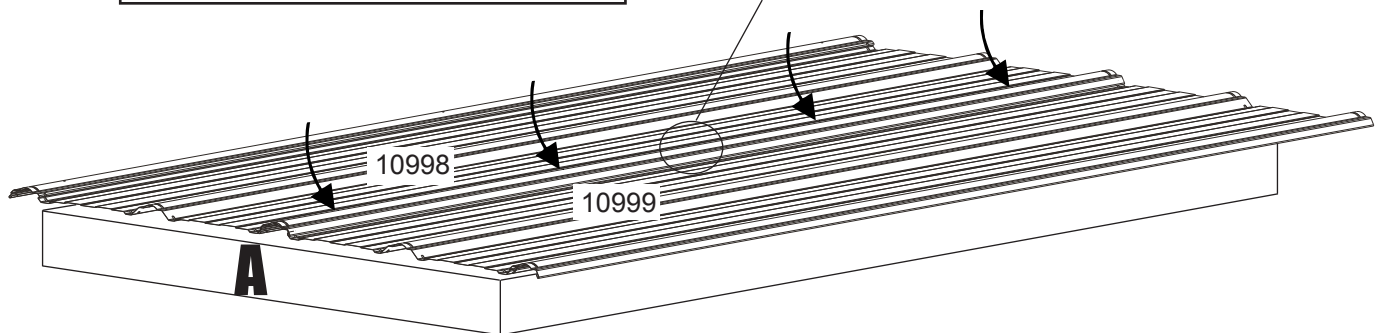
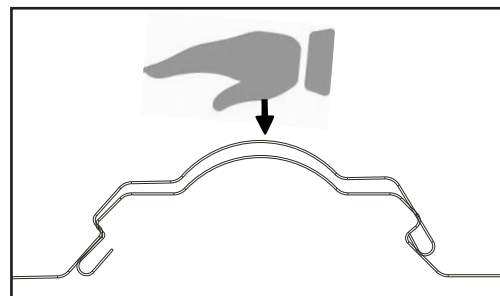
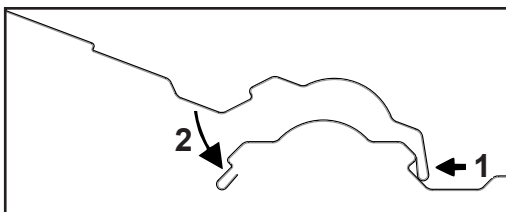
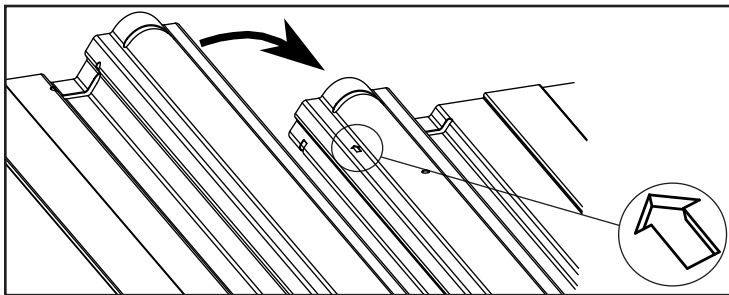
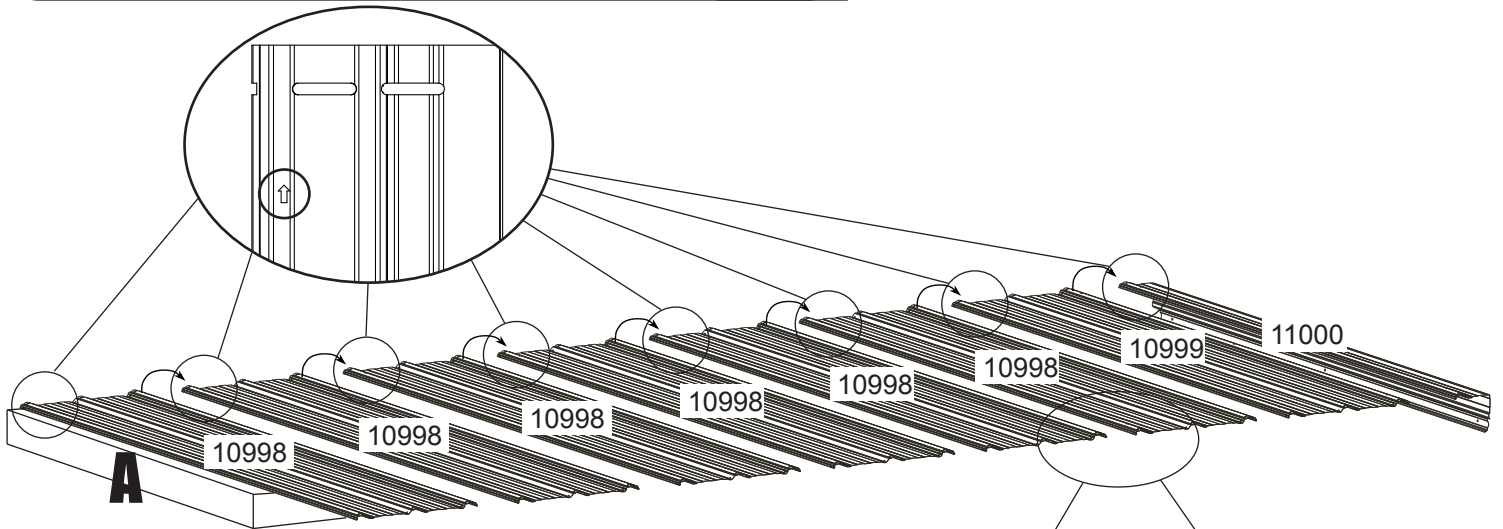
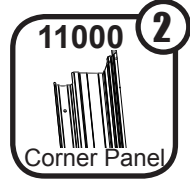
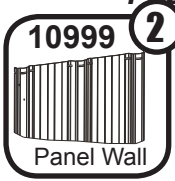
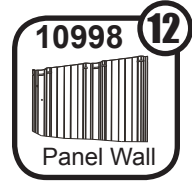

Step 1: Side Walls (2X)

You will need for this page:

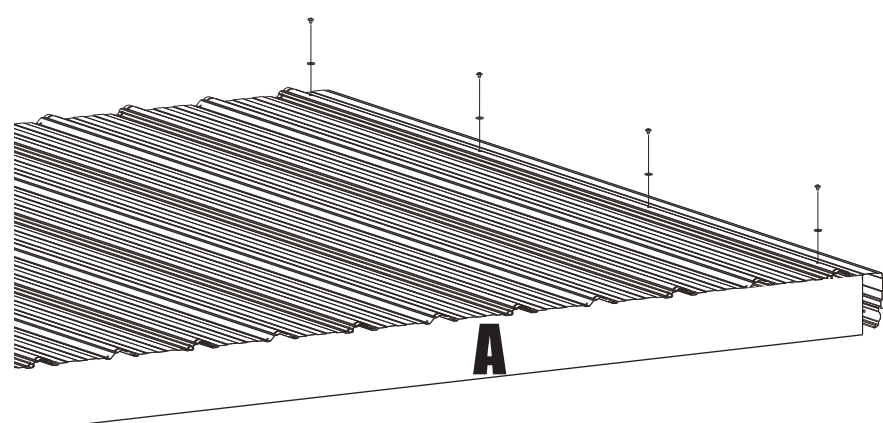
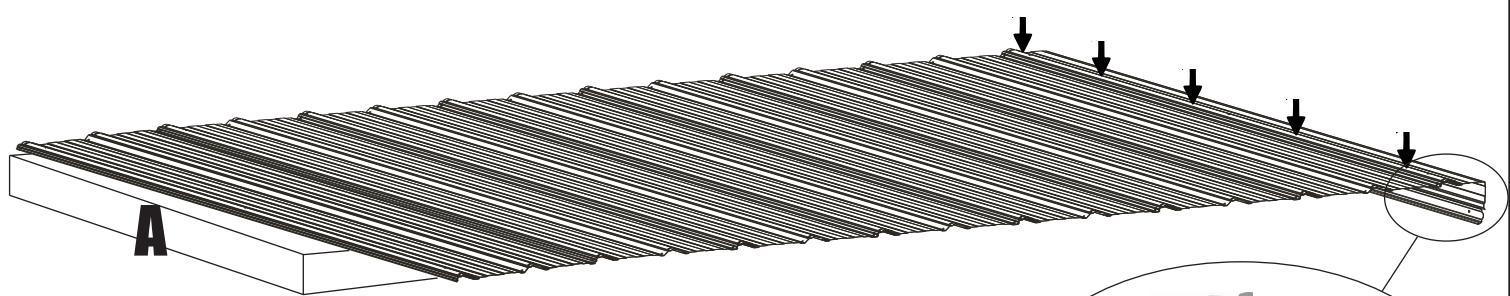
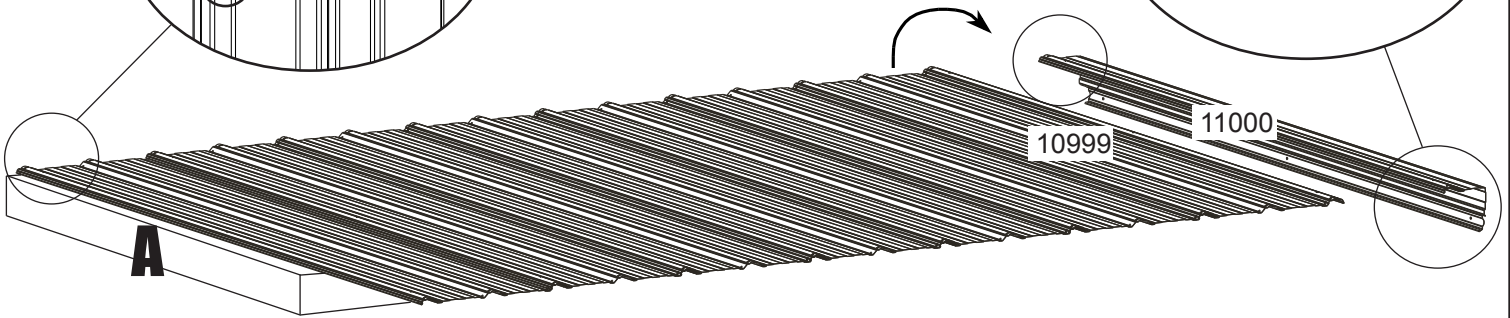
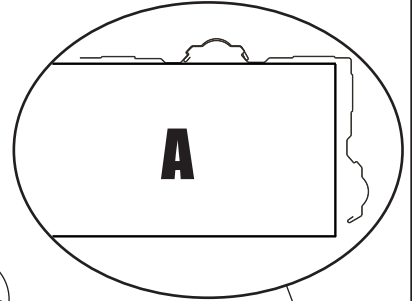
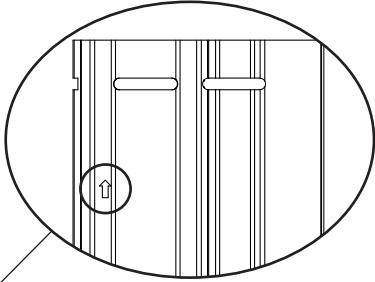
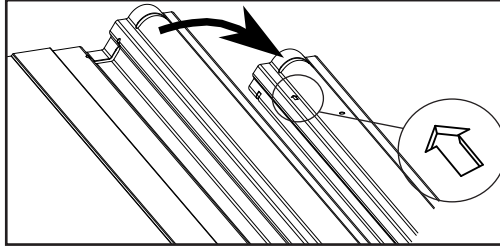
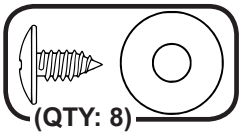

Step 1: Side Walls (2X)

You will need for this page:

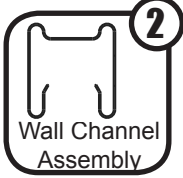

IMPORTANT
START ASSEMBLY AT CORNER PANEL

CORNER MUST BE AGAINST
45 DEGREE CUT ON CHANNEL

Channel

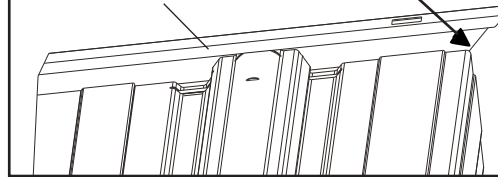

WALL CHANNEL ASSEMBLY
(Painted)

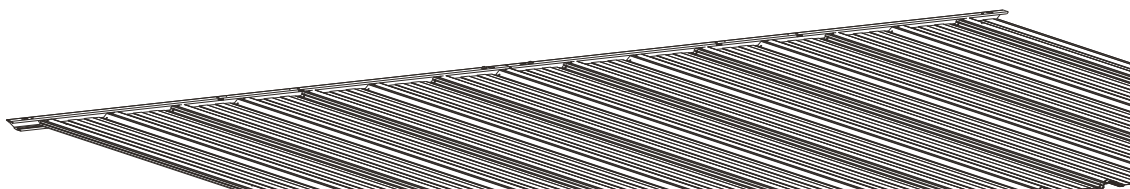
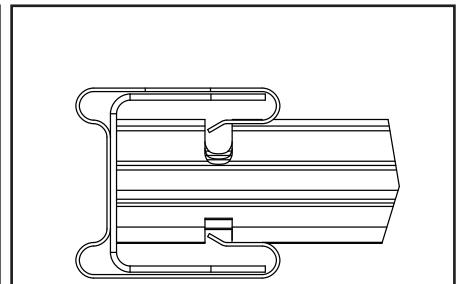
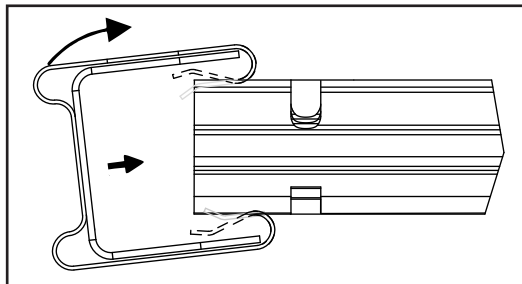
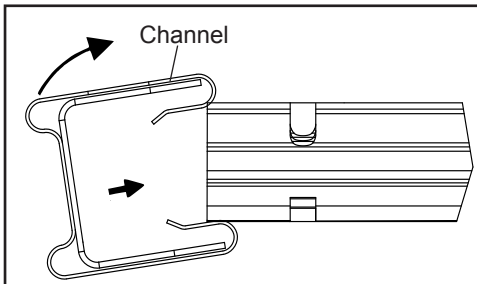
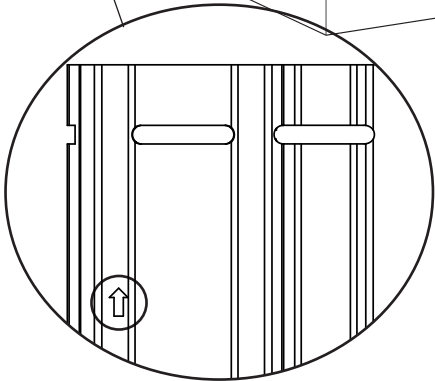
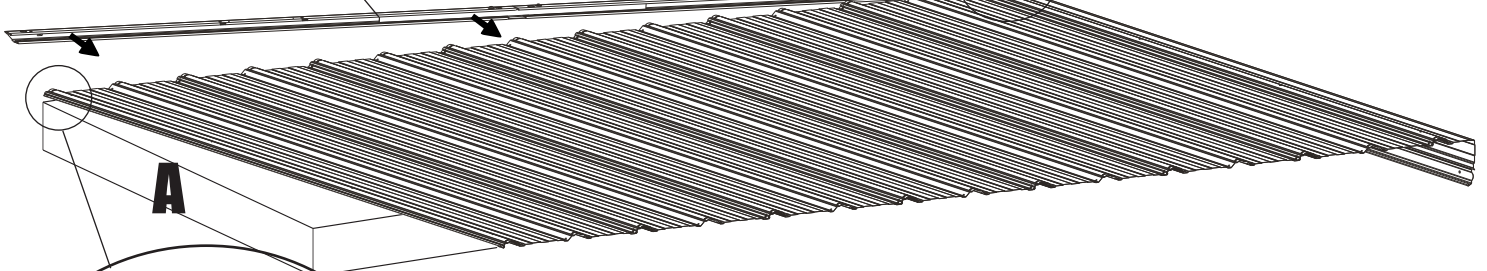

Step 1: Side Walls (2X)

You will need for this page:

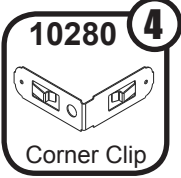
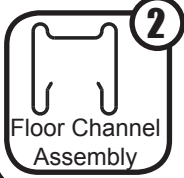

IMPORTANT START ASSEMBLY AT CORNER PANEL

CORNER MUST BE AGAINST
45 DEGREE CUT ON CHANNEL

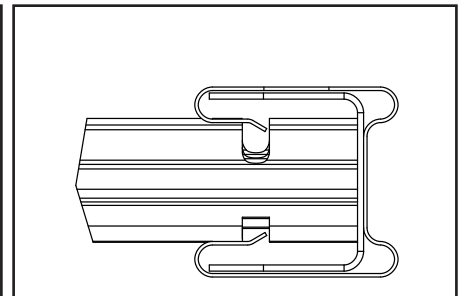
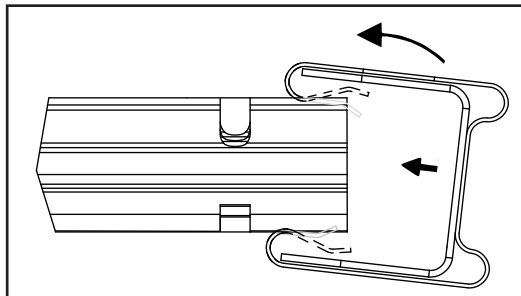
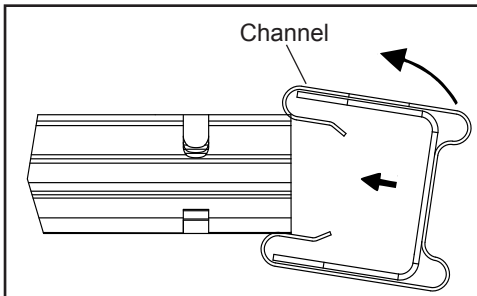
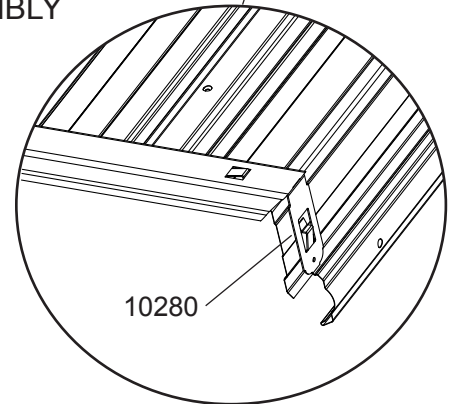
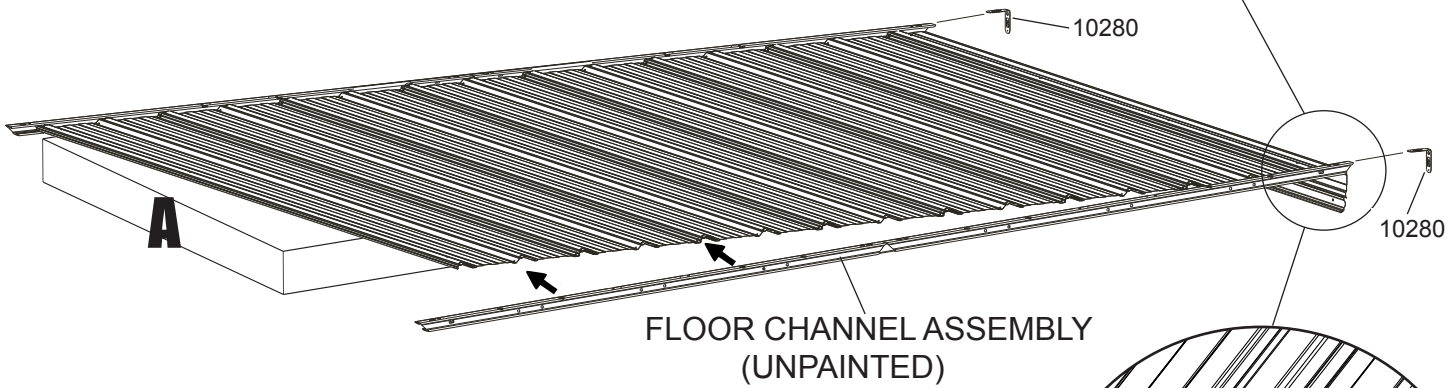
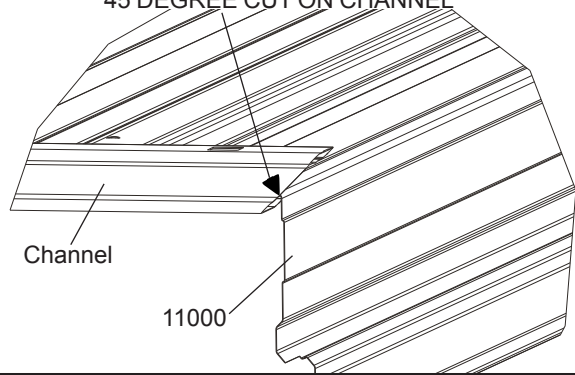

NOTE BE SURE TO MAKE TWO (2)
SIDE WALL SECTIONS.

Step 2: Rear Wall

You will need for this page:

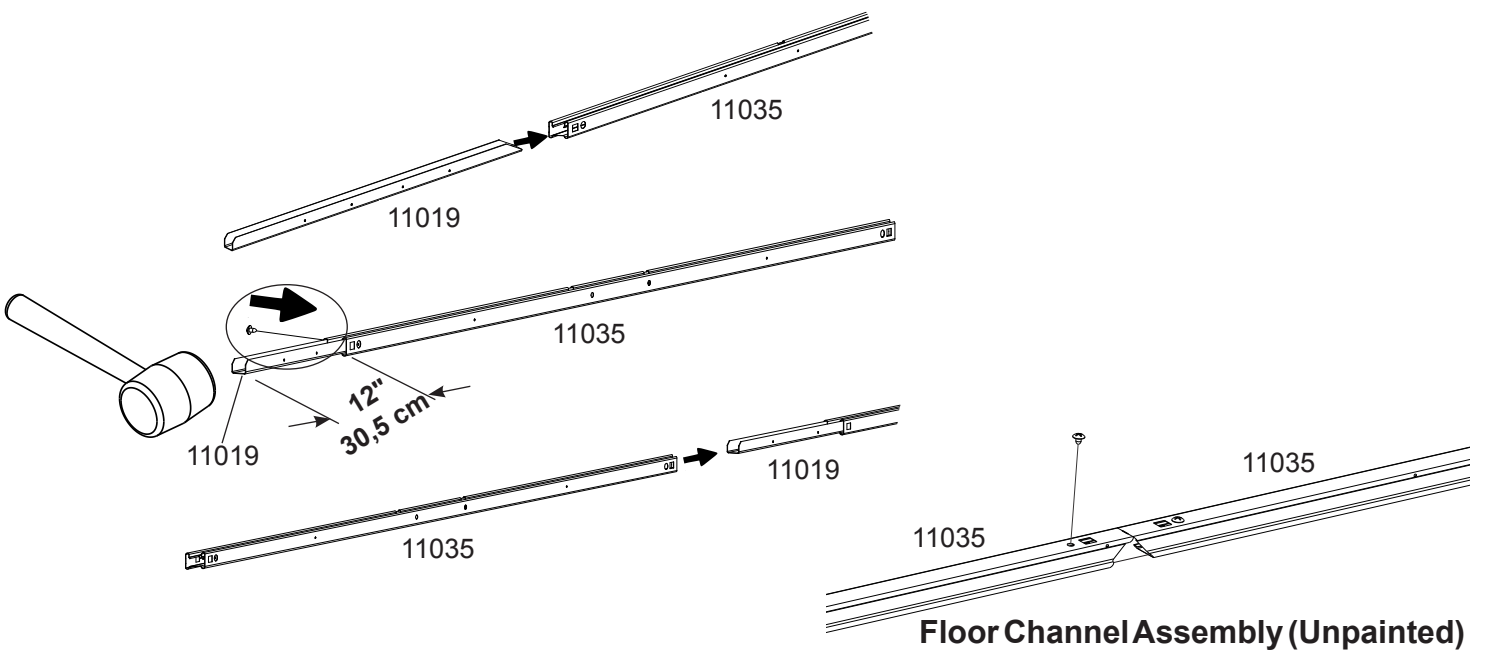
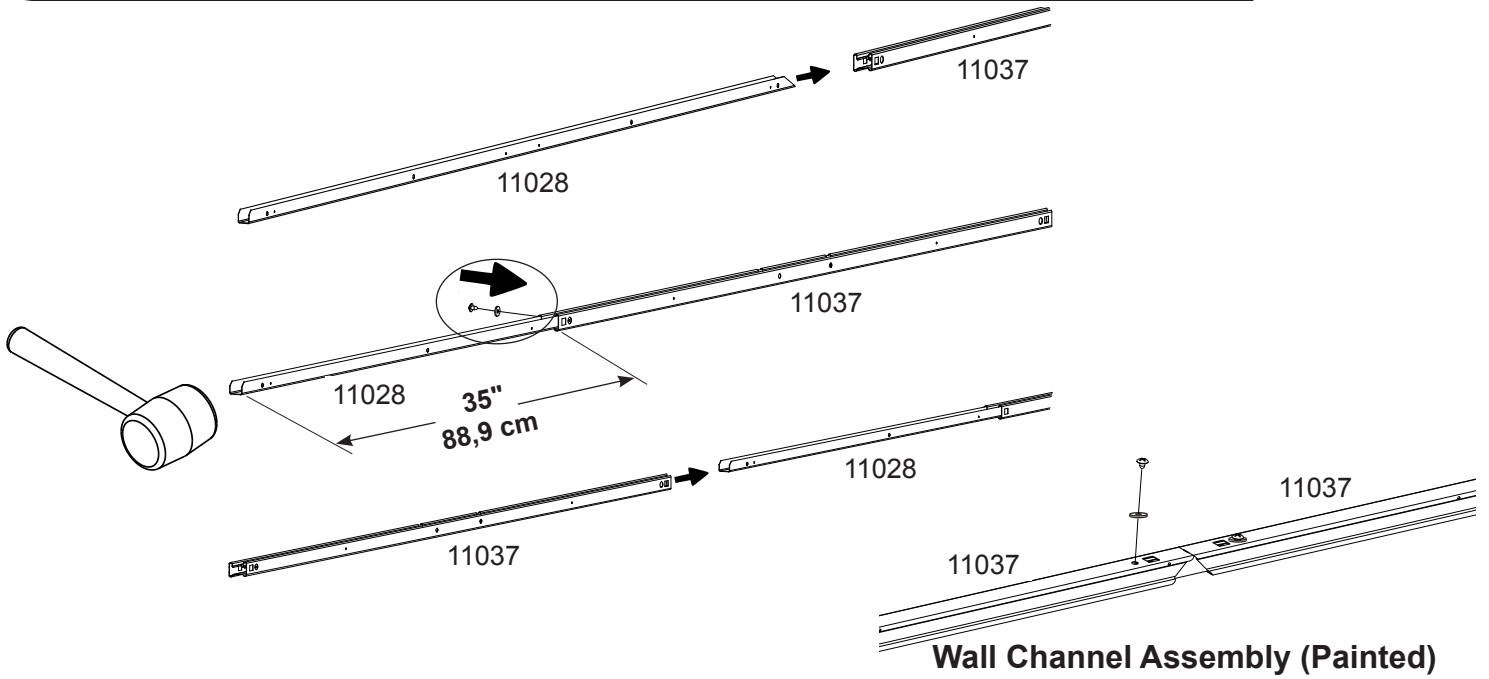
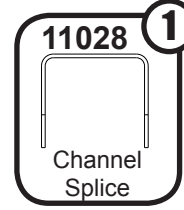
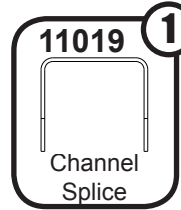
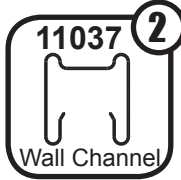
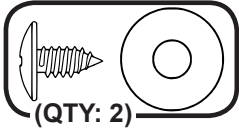

Step 2: Rear Wall

You will need for this page:

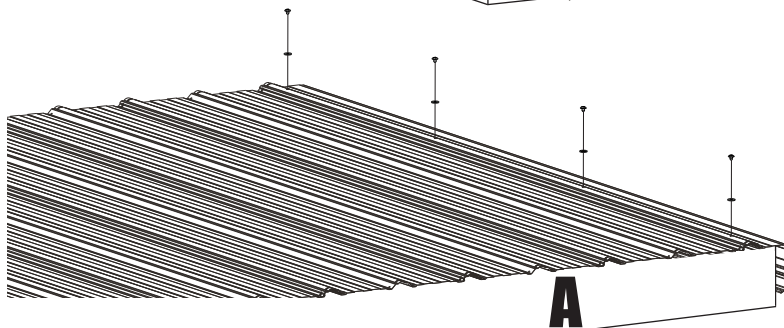
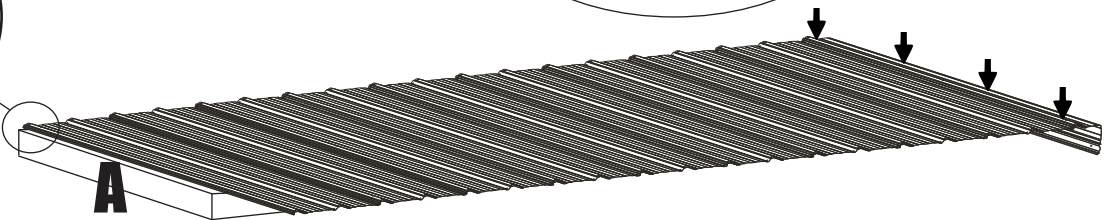
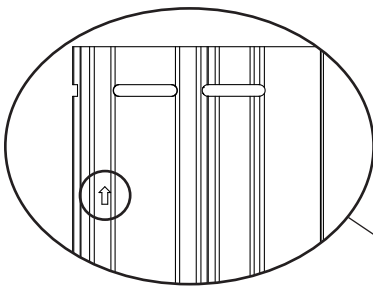
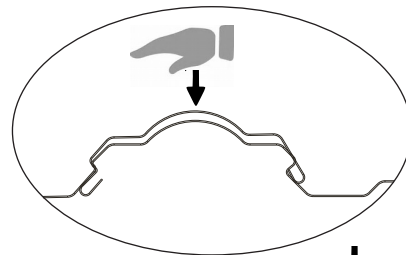
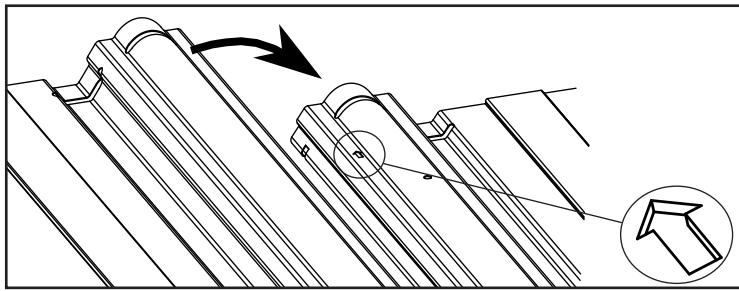
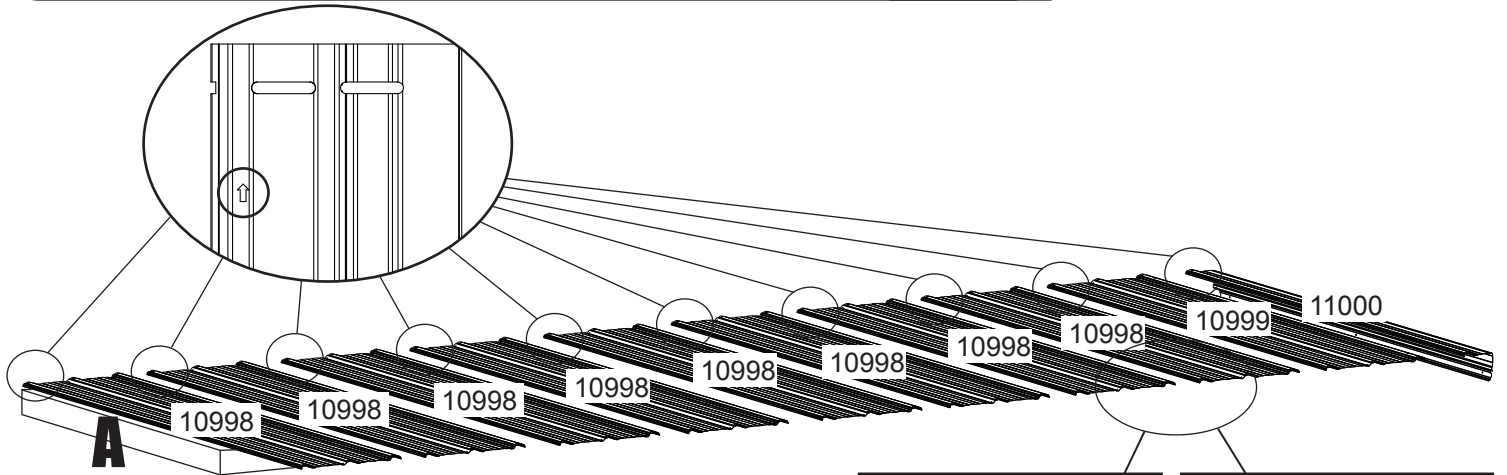
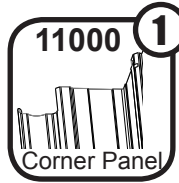
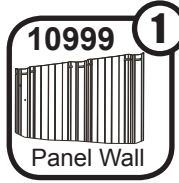
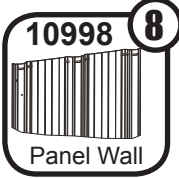
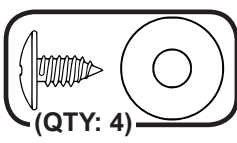

Step 2: Rear Wall

You will need for this page:

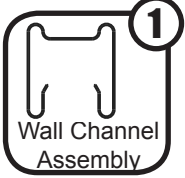

IMPORTANT
START ASSEMBLY AT CORNER PANEL

CORNER MUST BE AGAINST
45 DEGREE CUT ON CHANNEL

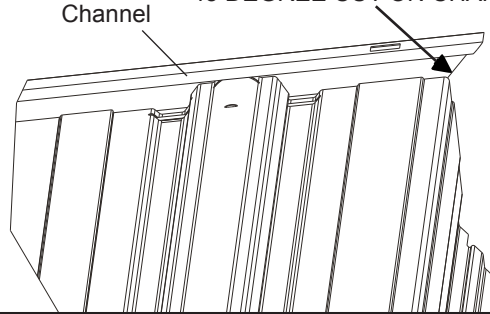

WALL CHANNEL ASSEMBLY
(Painted)

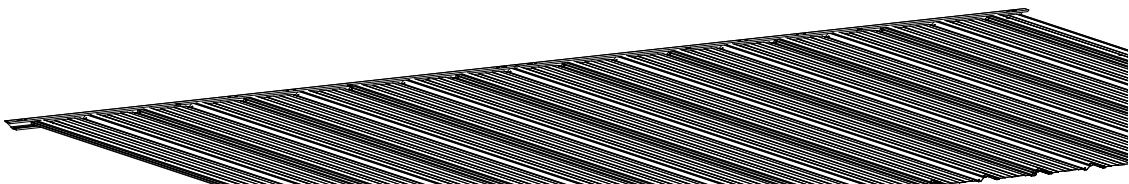
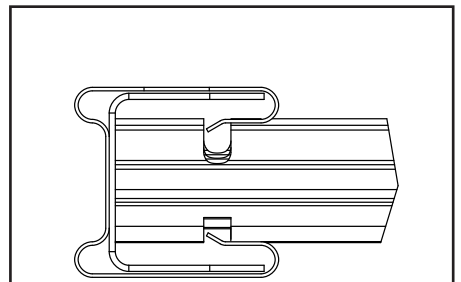
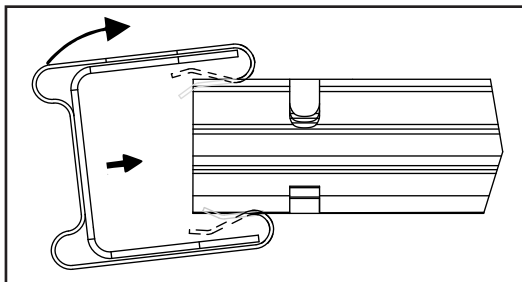
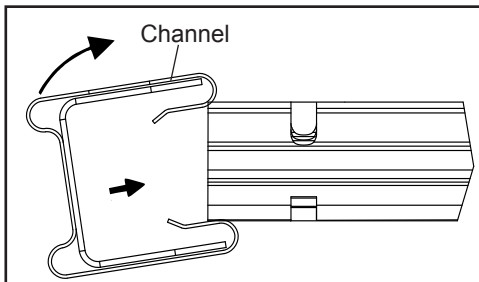
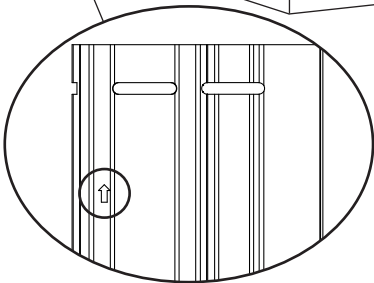
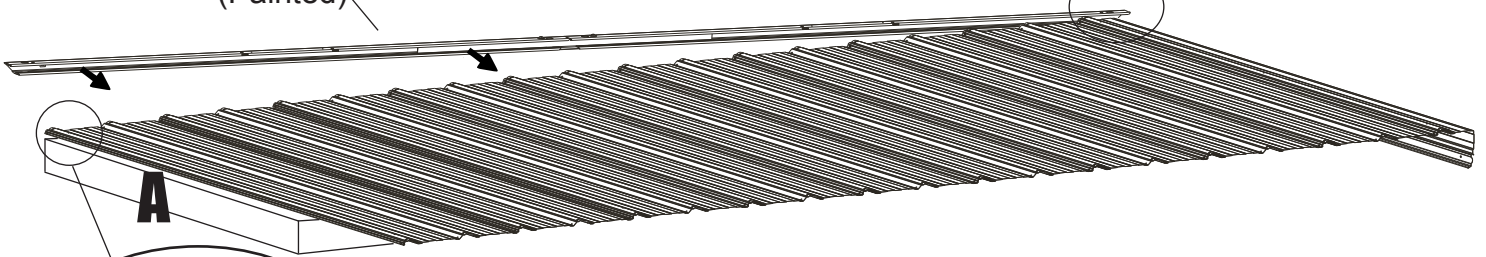

Step 2: Rear Wall

You will need for this page:

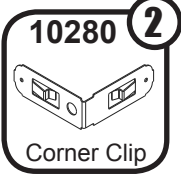
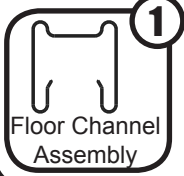

IMPORTANT START ASSEMBLY AT CORNER PANEL

CORNER MUST BE AGAINST
45 DEGREE CUT ON CHANNEL

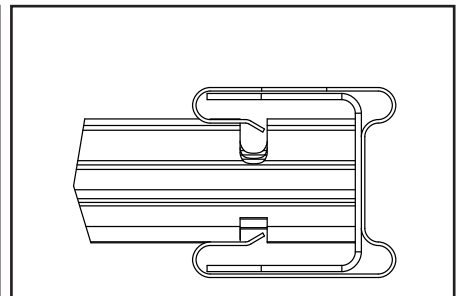
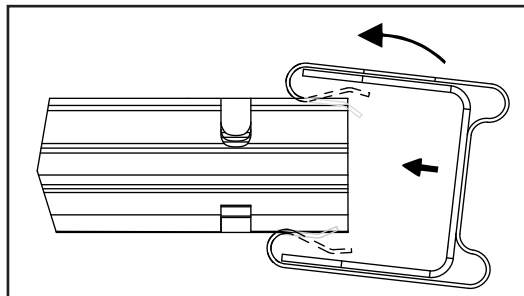
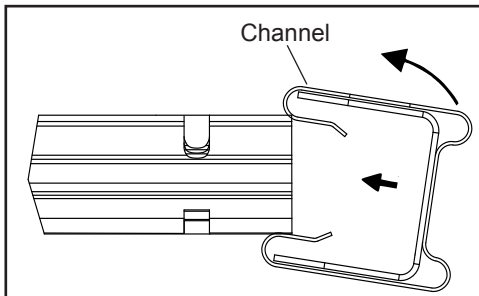
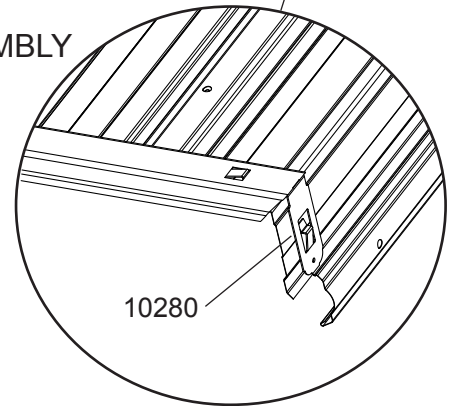
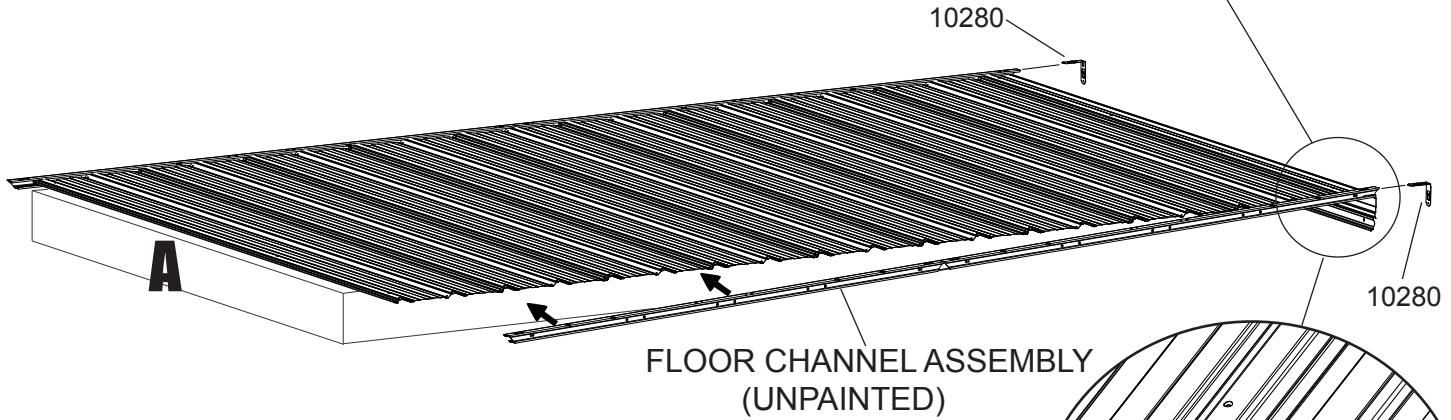
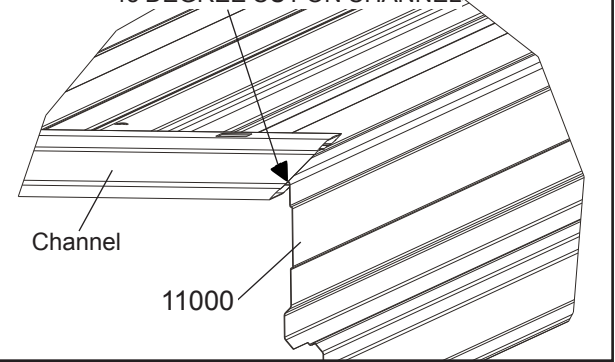

Step 3: Front Wall

You will need for this page:

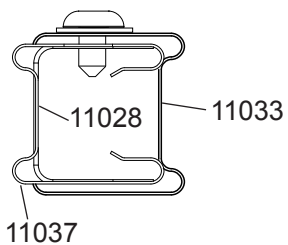
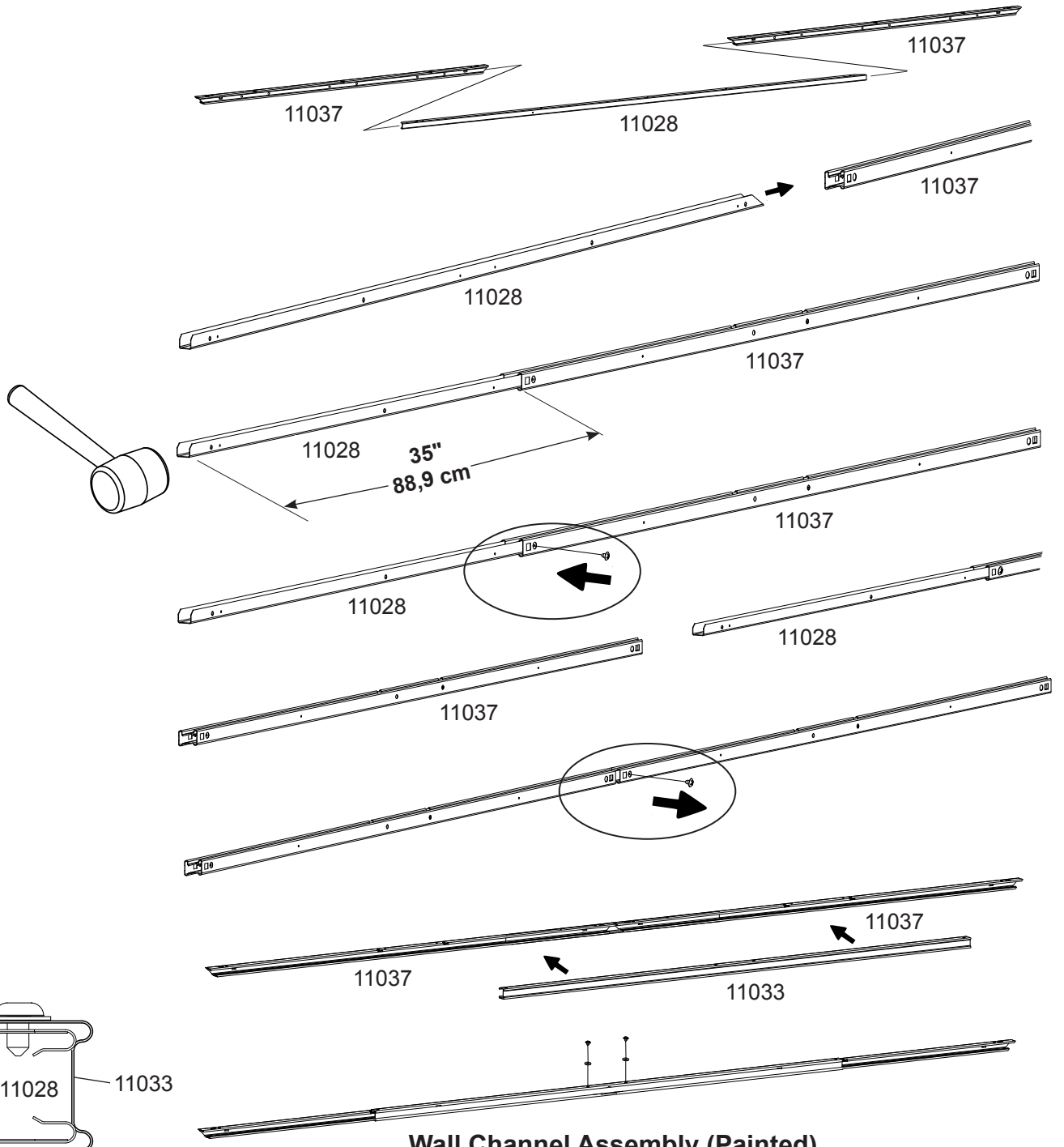
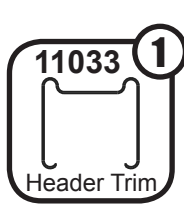
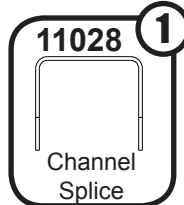
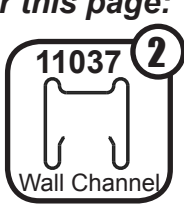
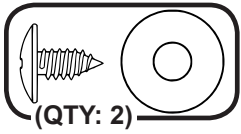

Wall Channel Assembly (Painted)

Step 3: Front Wall

You will need for this page:

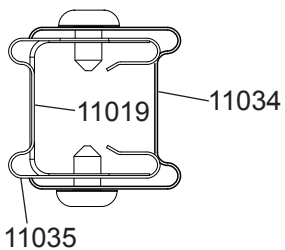
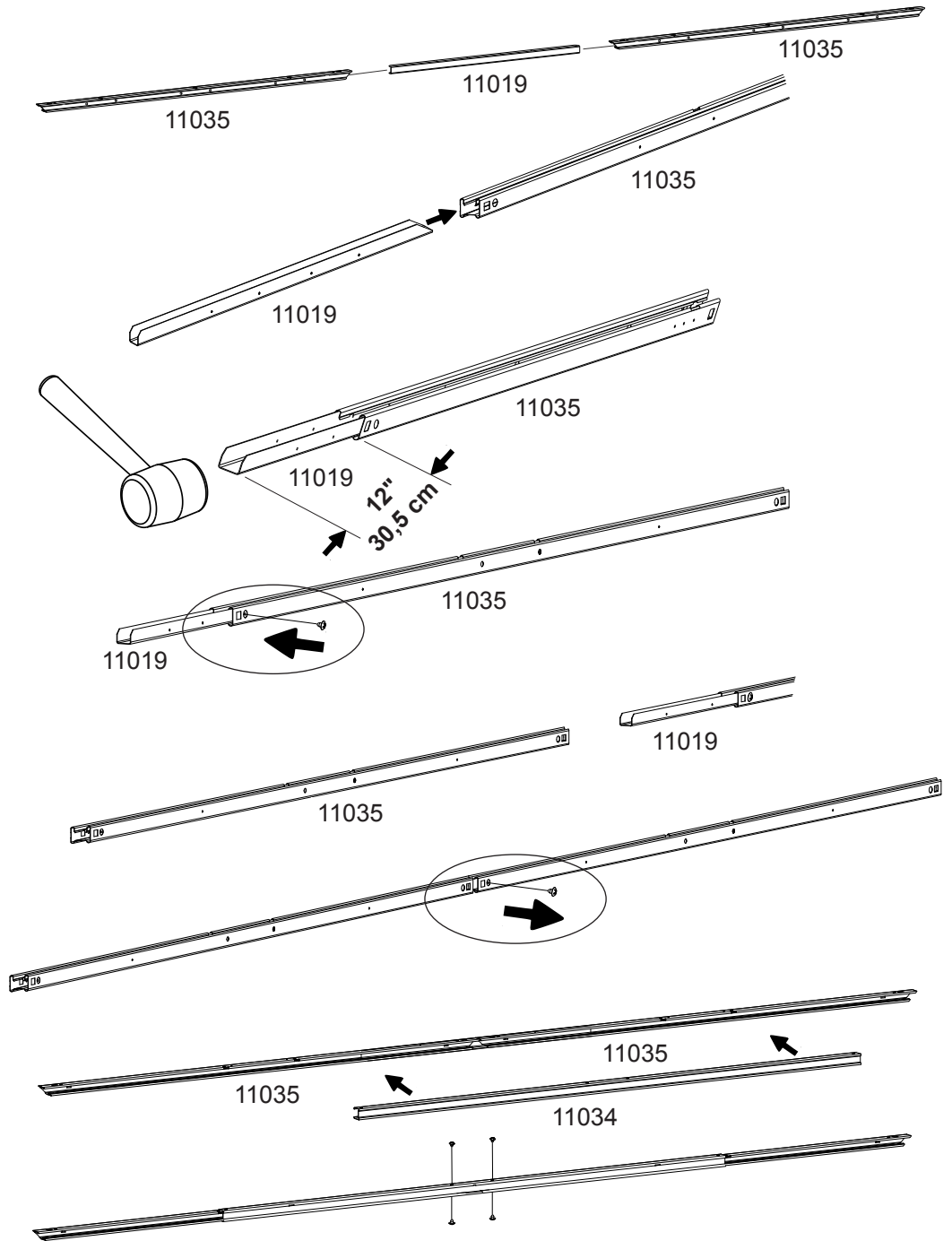
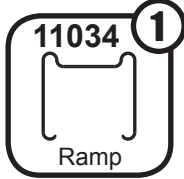
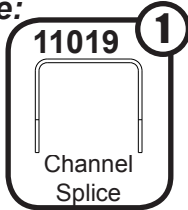
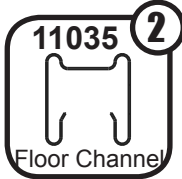

Floor Channel Assembly (Unpainted)

Step 3: Front Wall

You will need for this page:

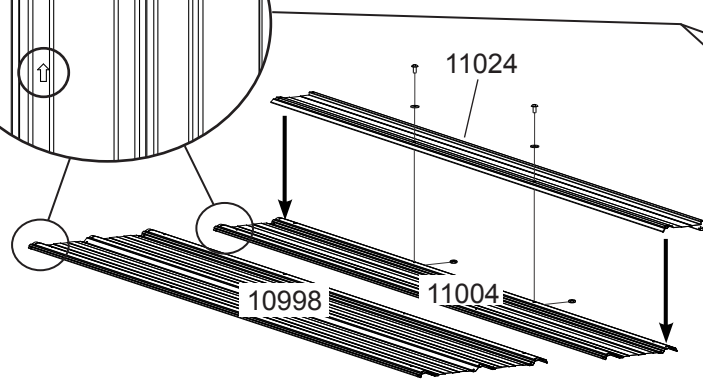
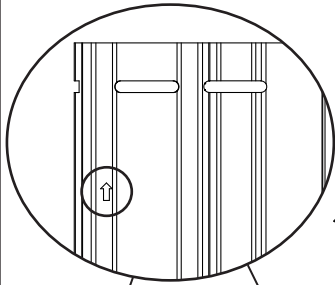
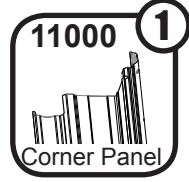
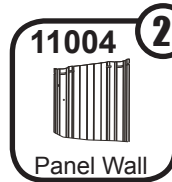
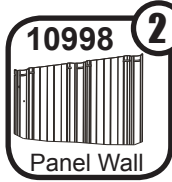
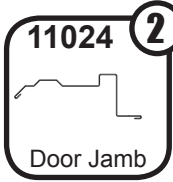
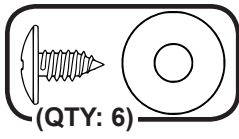
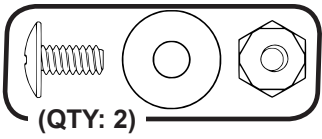

LEFT

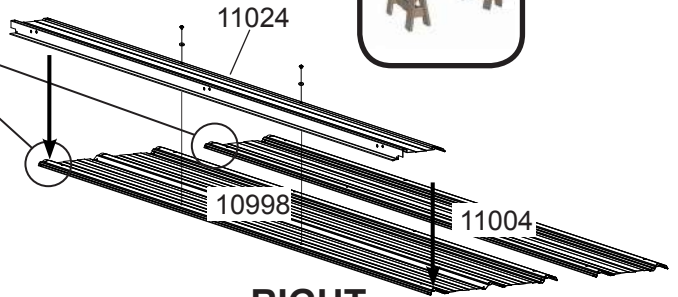

RIGHT

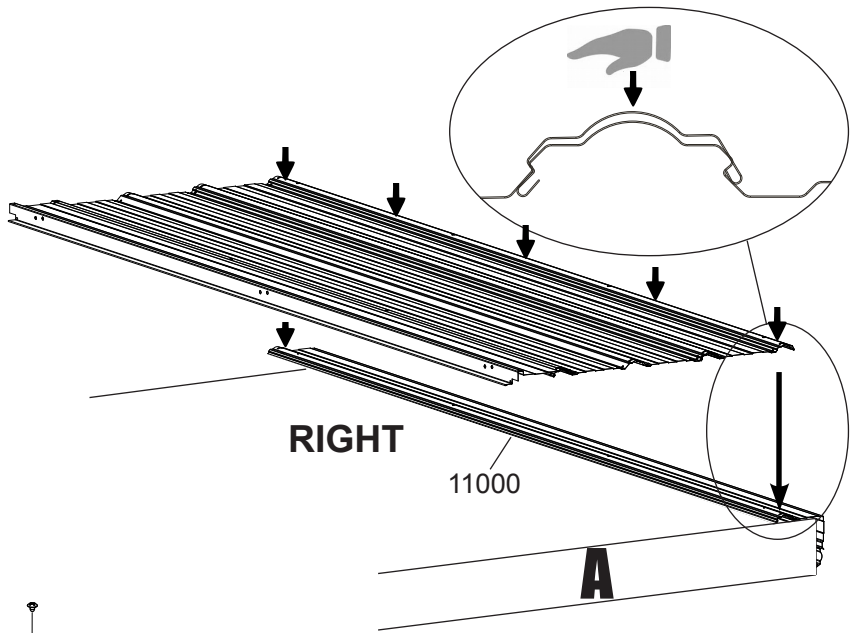

RIGHT

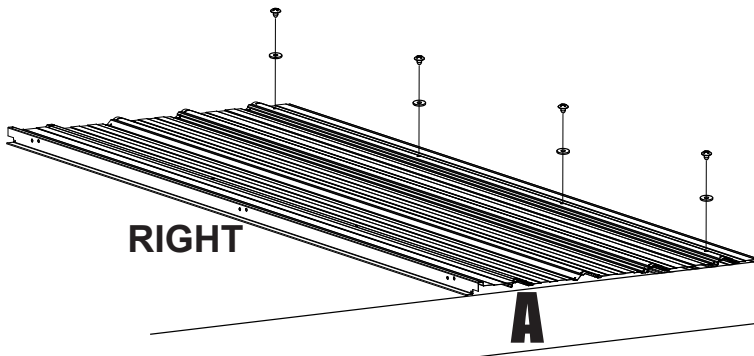

RIGHT

Step 3: Front Wall

You will need for this page:

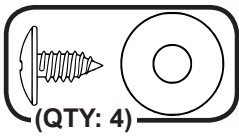
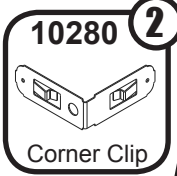
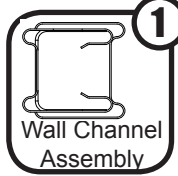
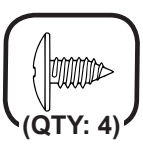

WALL CHANNEL ASSEMBLY
(Painted)

IMPORTANT
START ASSEMBLY AT CORNER PANEL

CORNER MUST BE AGAINST
45 DEGREE CUT ON CHANNEL

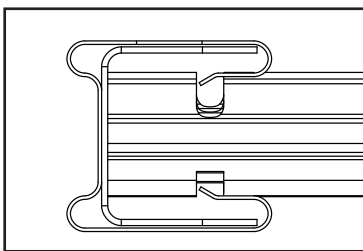
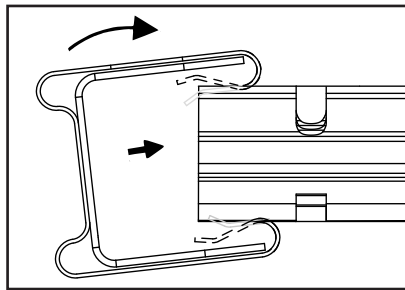
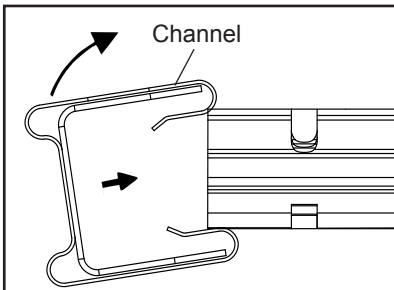
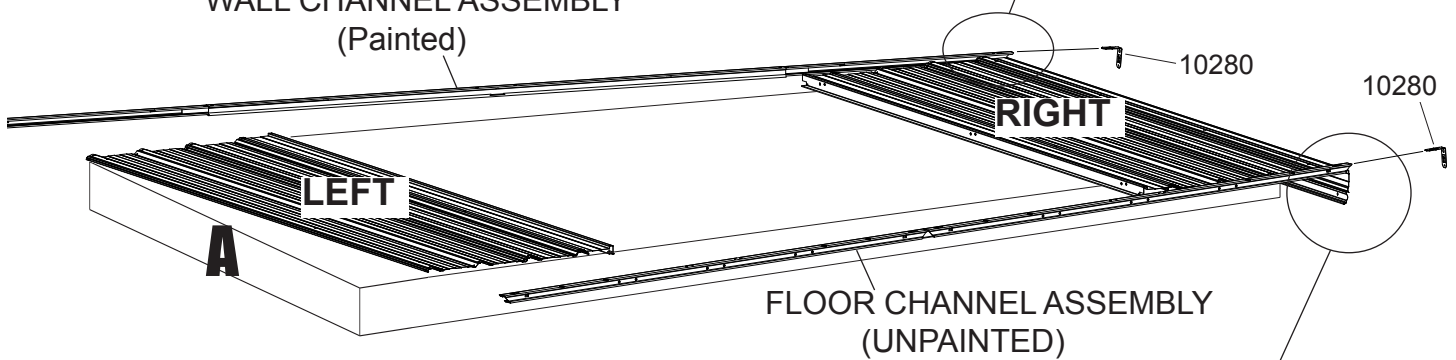
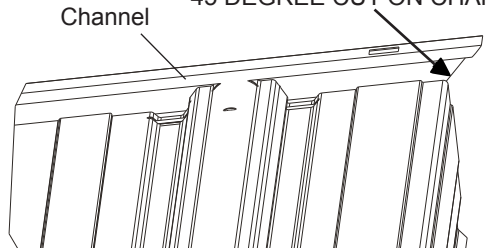

IMPORTANT
START ASSEMBLY AT CORNER PANEL

CORNER MUST BE AGAINST
45 DEGREE CUT ON CHANNEL

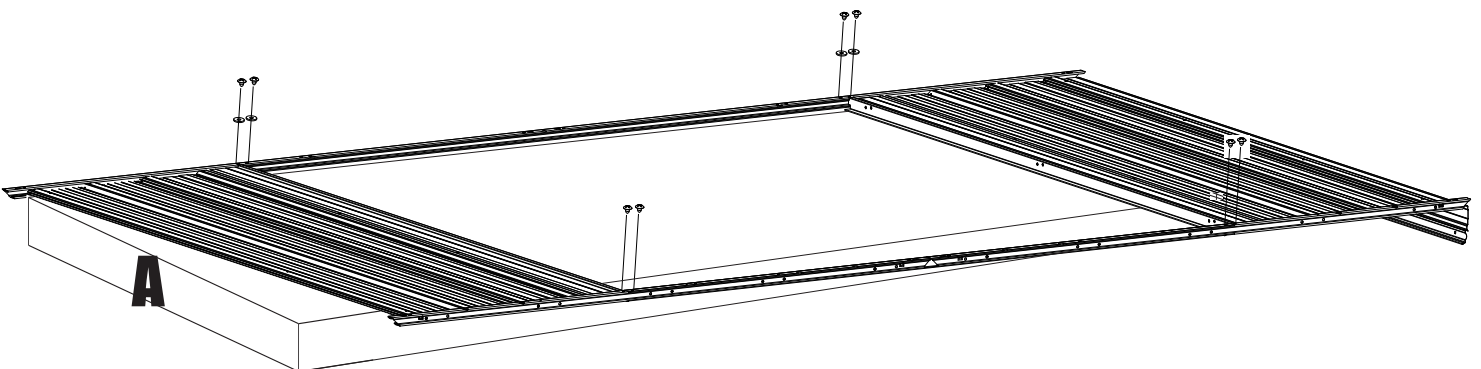
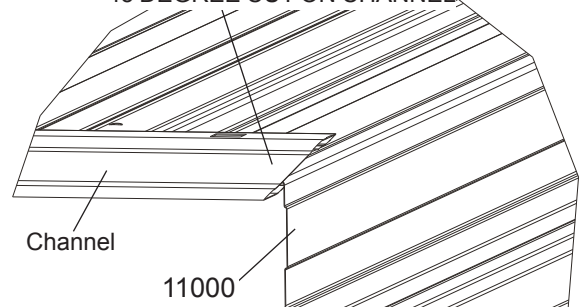

Step 4: Right Door Assy

You will need for this page:

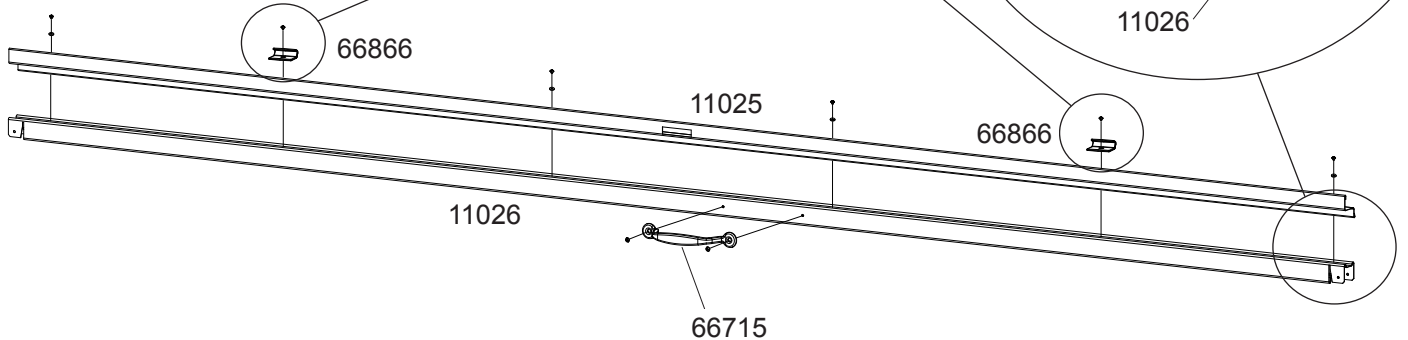
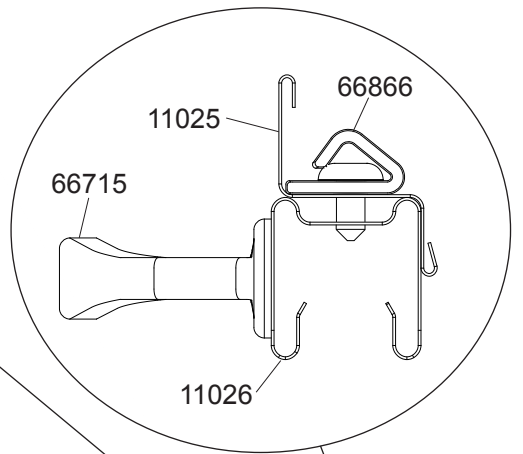
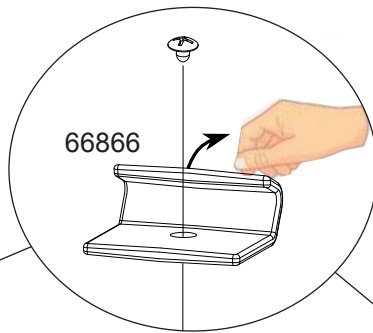
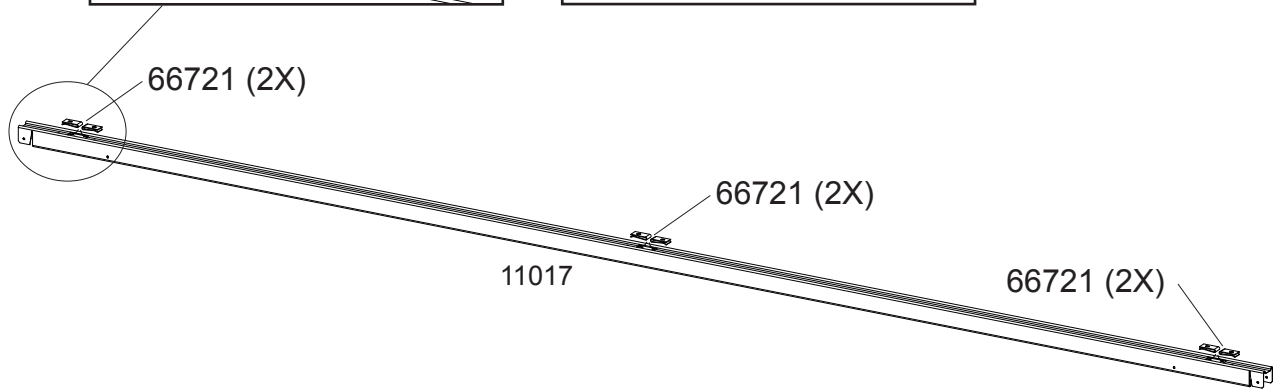
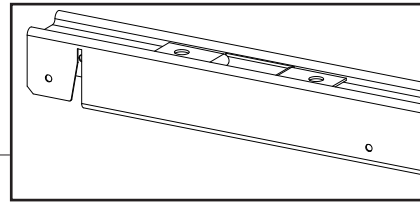
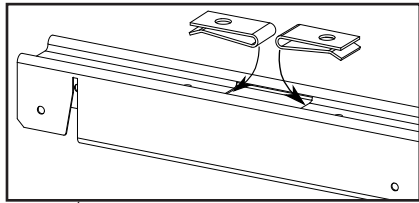
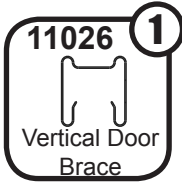
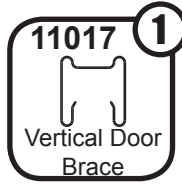
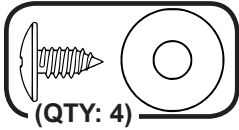

Step 4: Right Door Assy

You will need for this page:

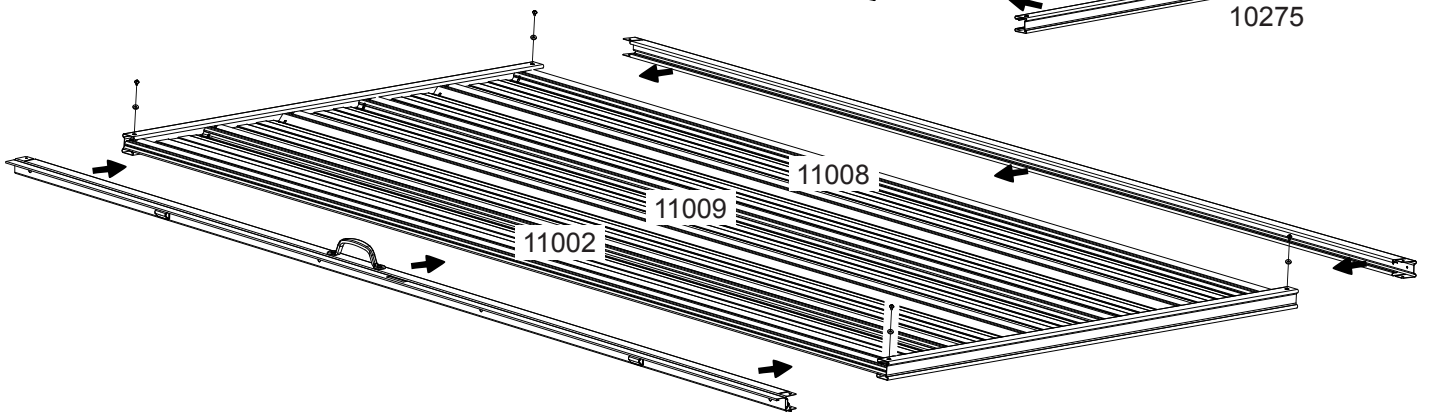
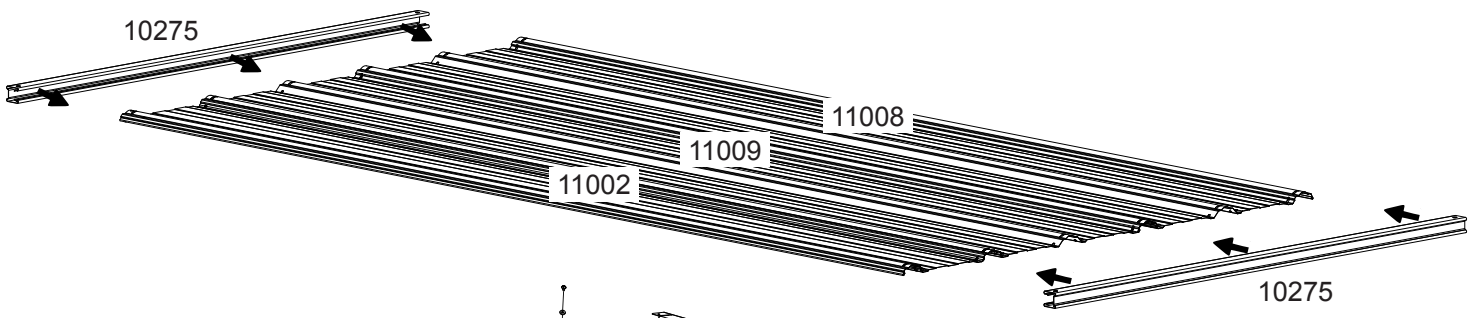
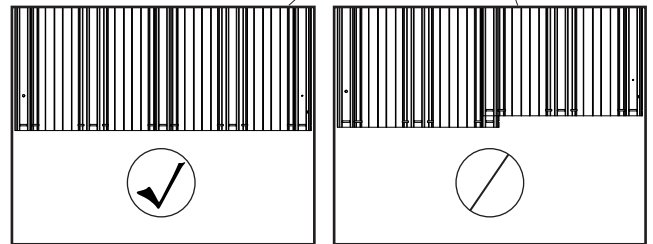
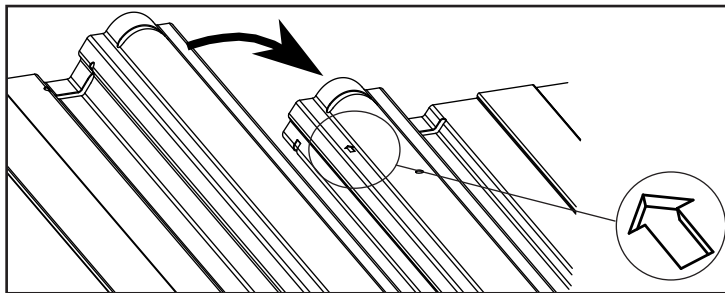
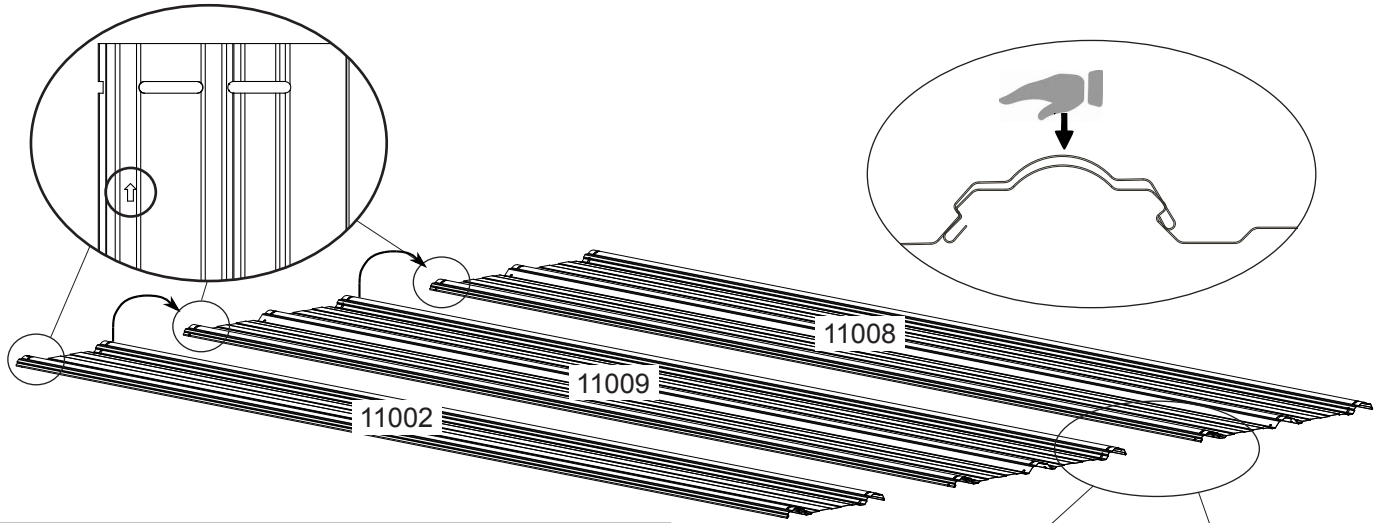
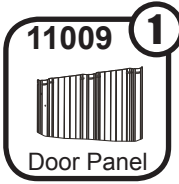
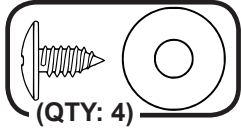

Step 4: Right Door Assy

You will need for this page:

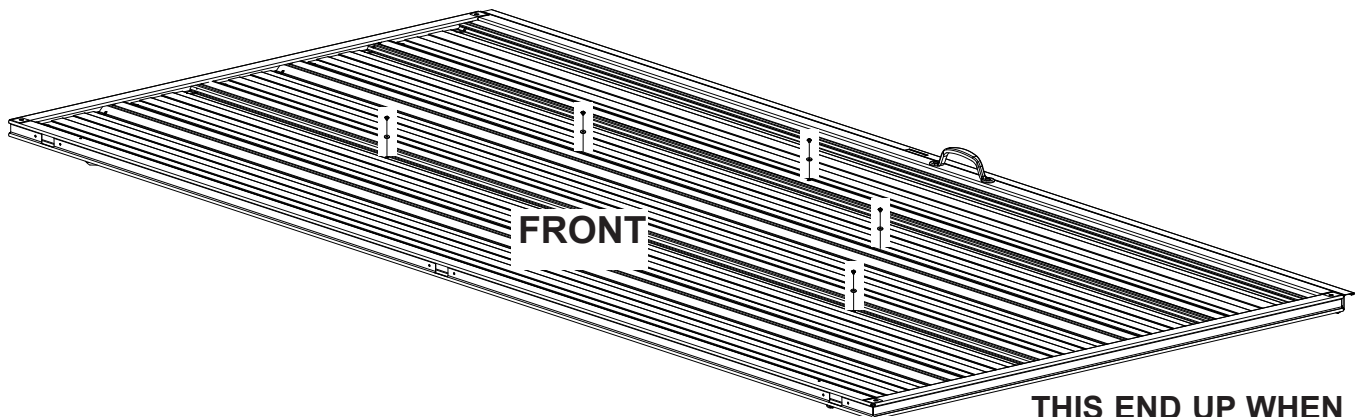
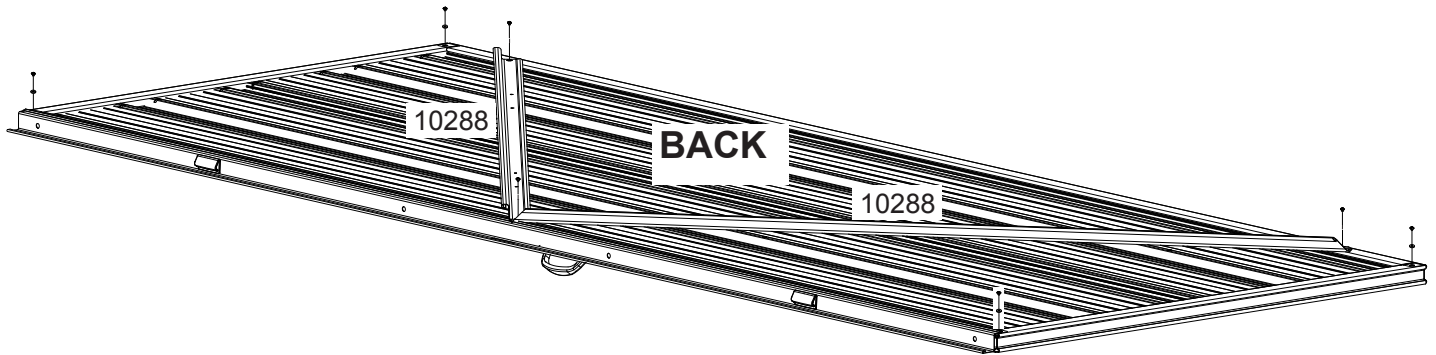
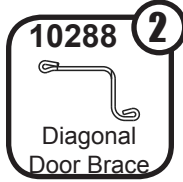

THIS END UP WHEN
HANGING DOOR

Step 5: Left Door Assy

You will need for this page:

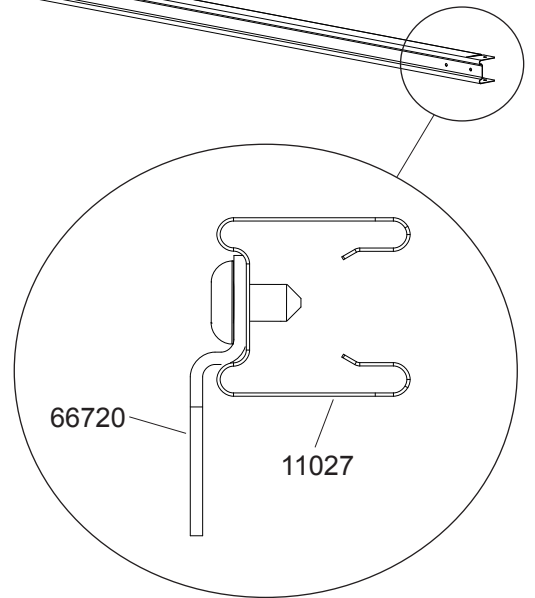
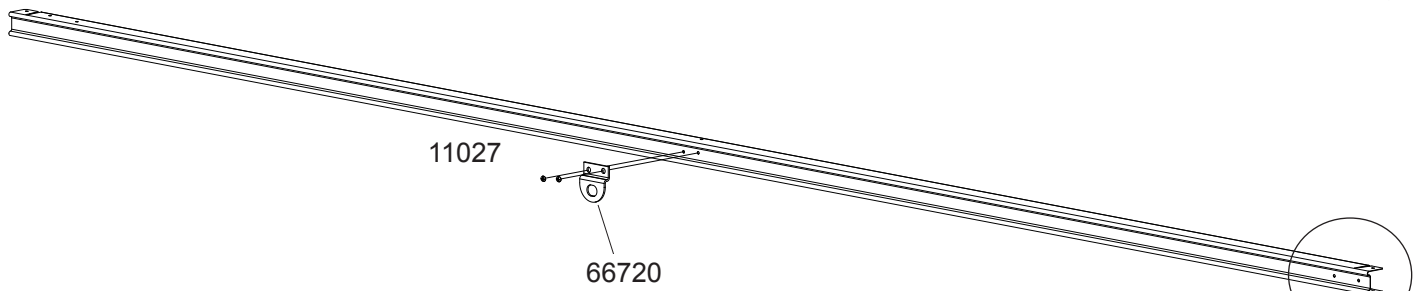
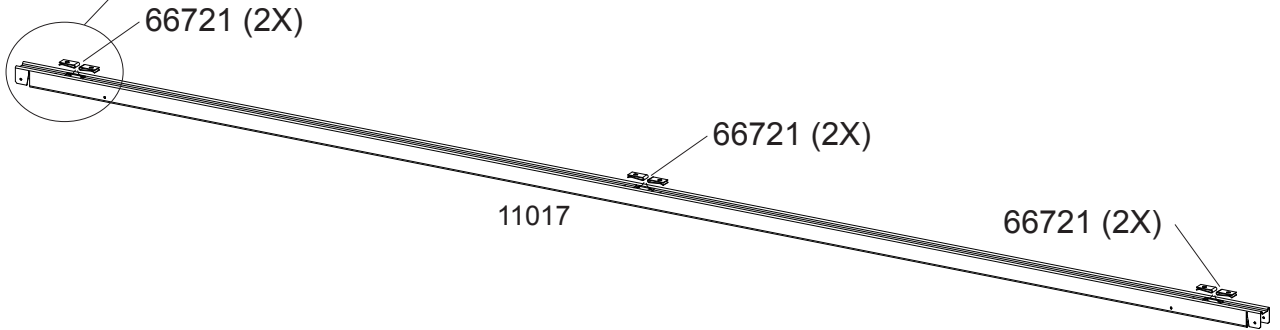
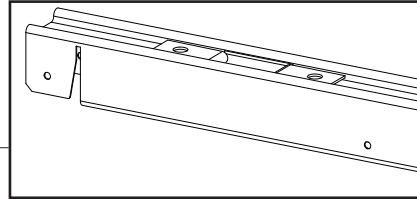
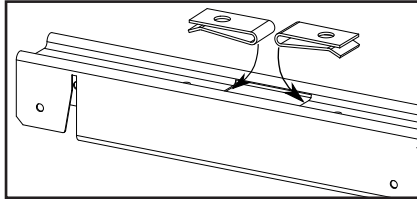

Step 5: Left Door Assy

You will need for this page:

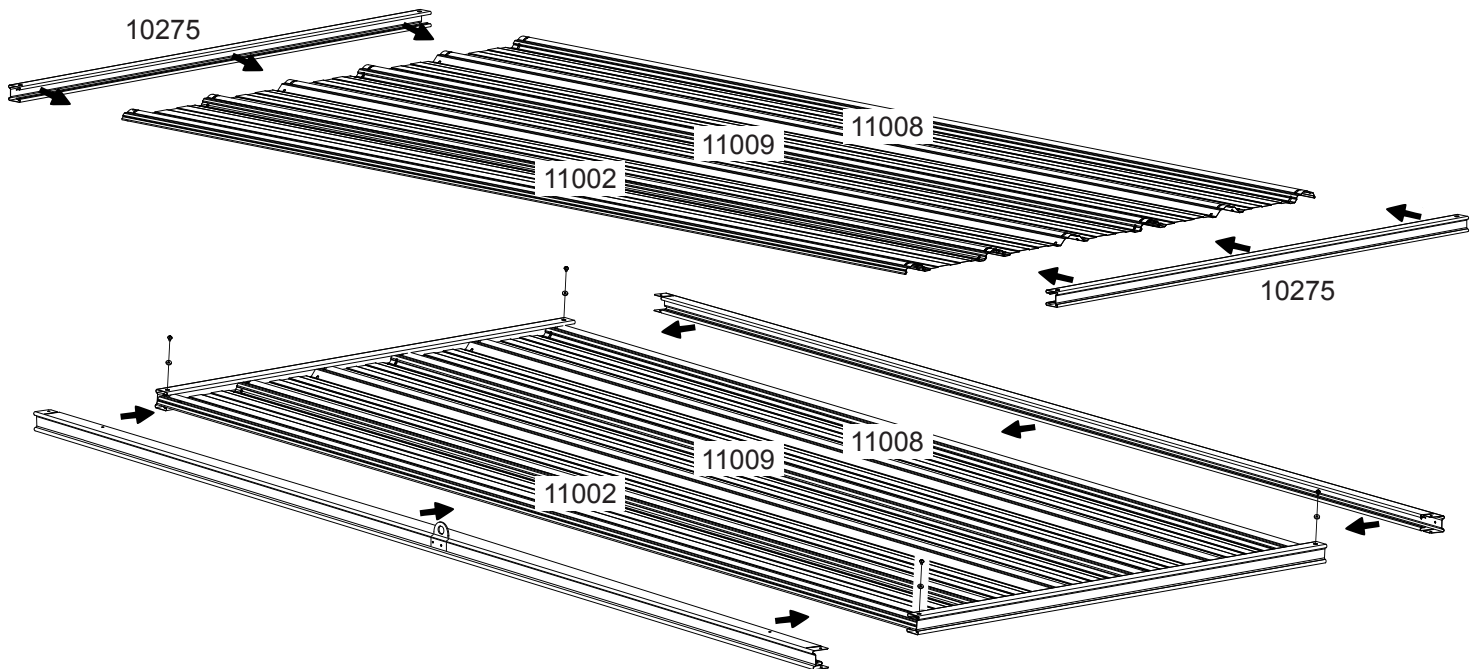
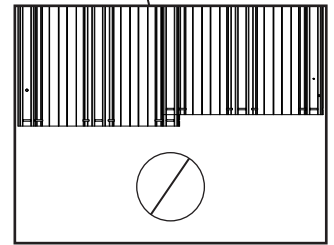
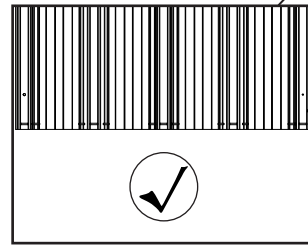
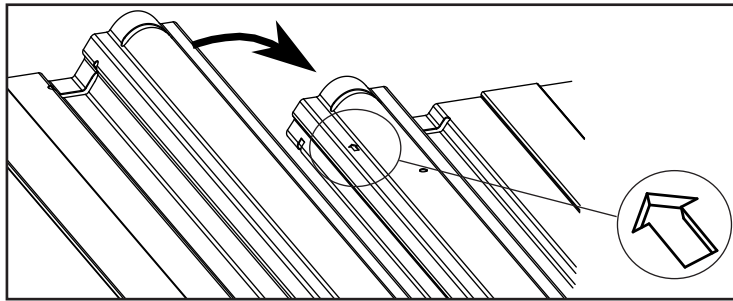
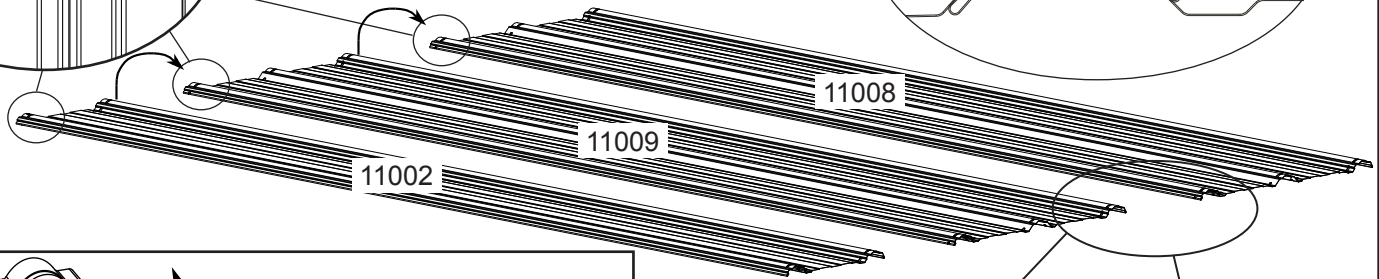
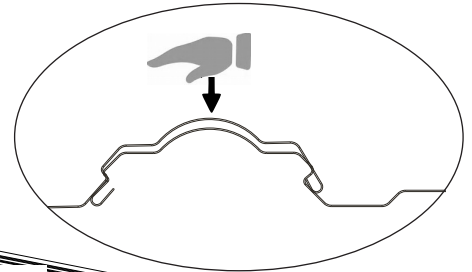
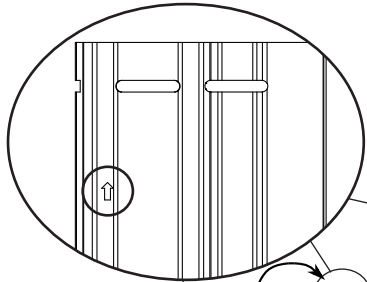
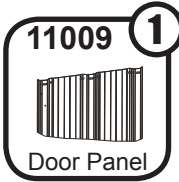
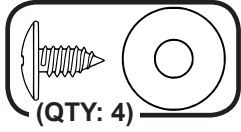

Step 5: Left Door Assy

You will need for this page:

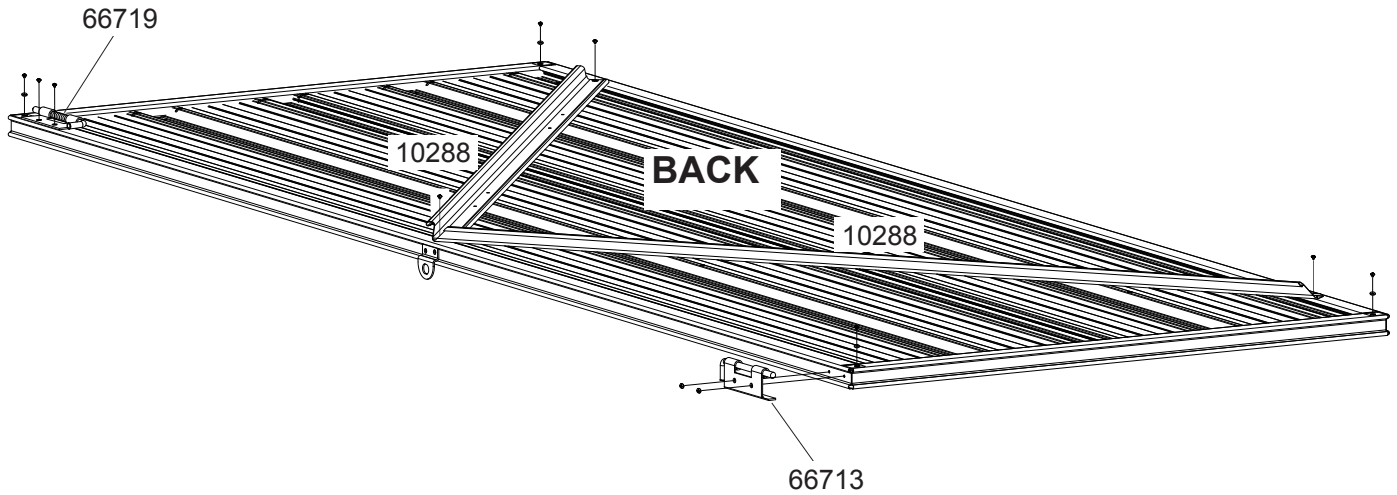
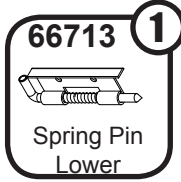
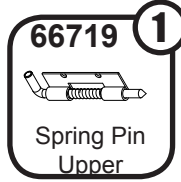
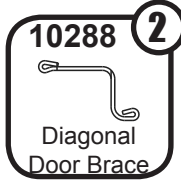
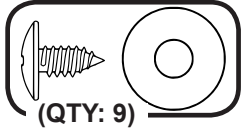

**THIS END UP WHEN
HANGING DOOR**

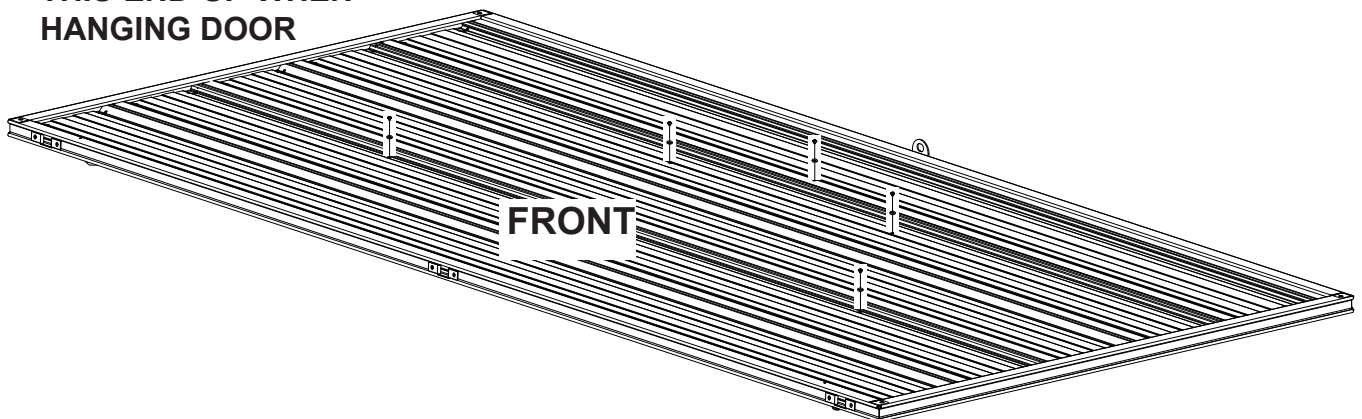

Step 6: Roof pre-assy

You will need for this page:

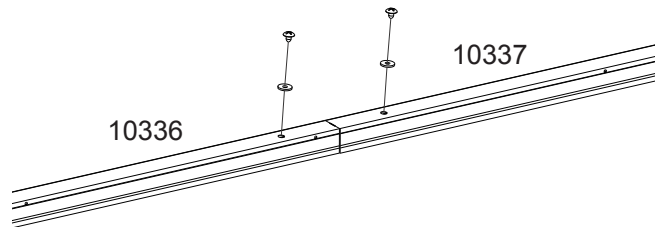
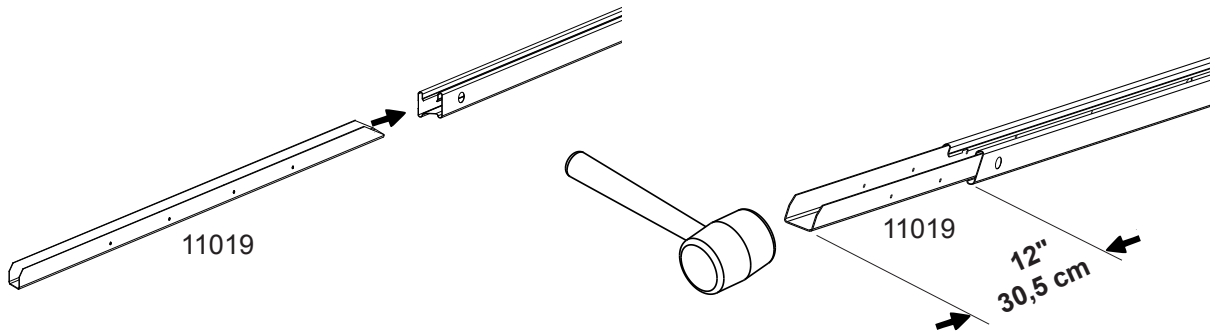
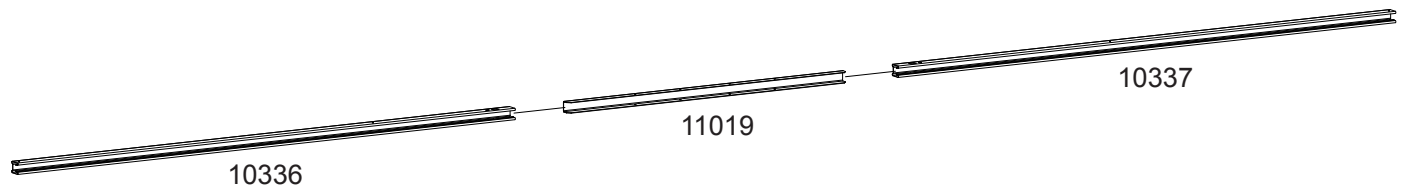
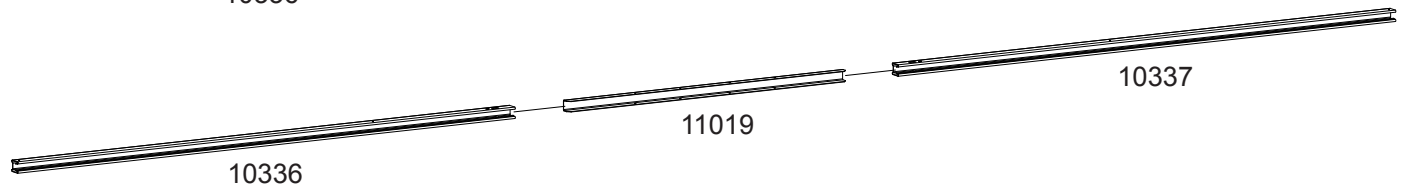
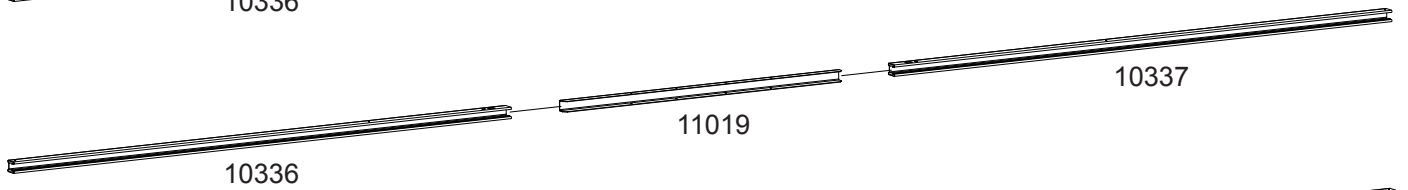
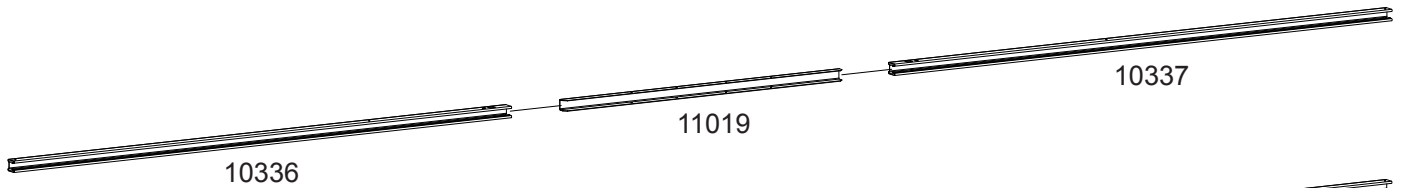
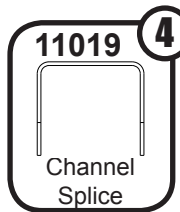
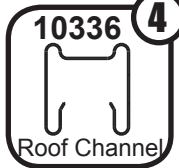
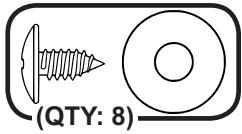

Step 6: Roof pre-assy (2X)

You will need for this page:

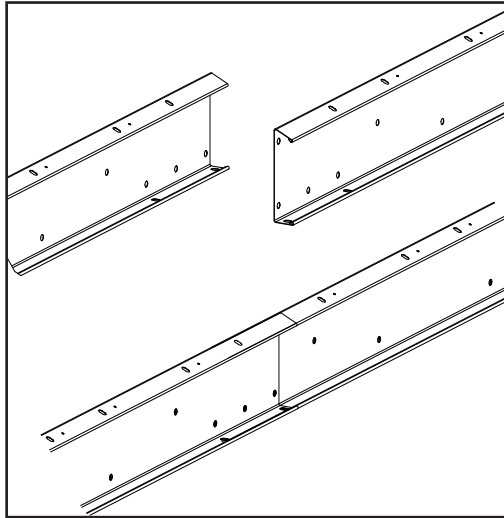
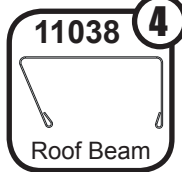
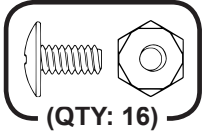

Overlap Length
6" (15,2 cm)

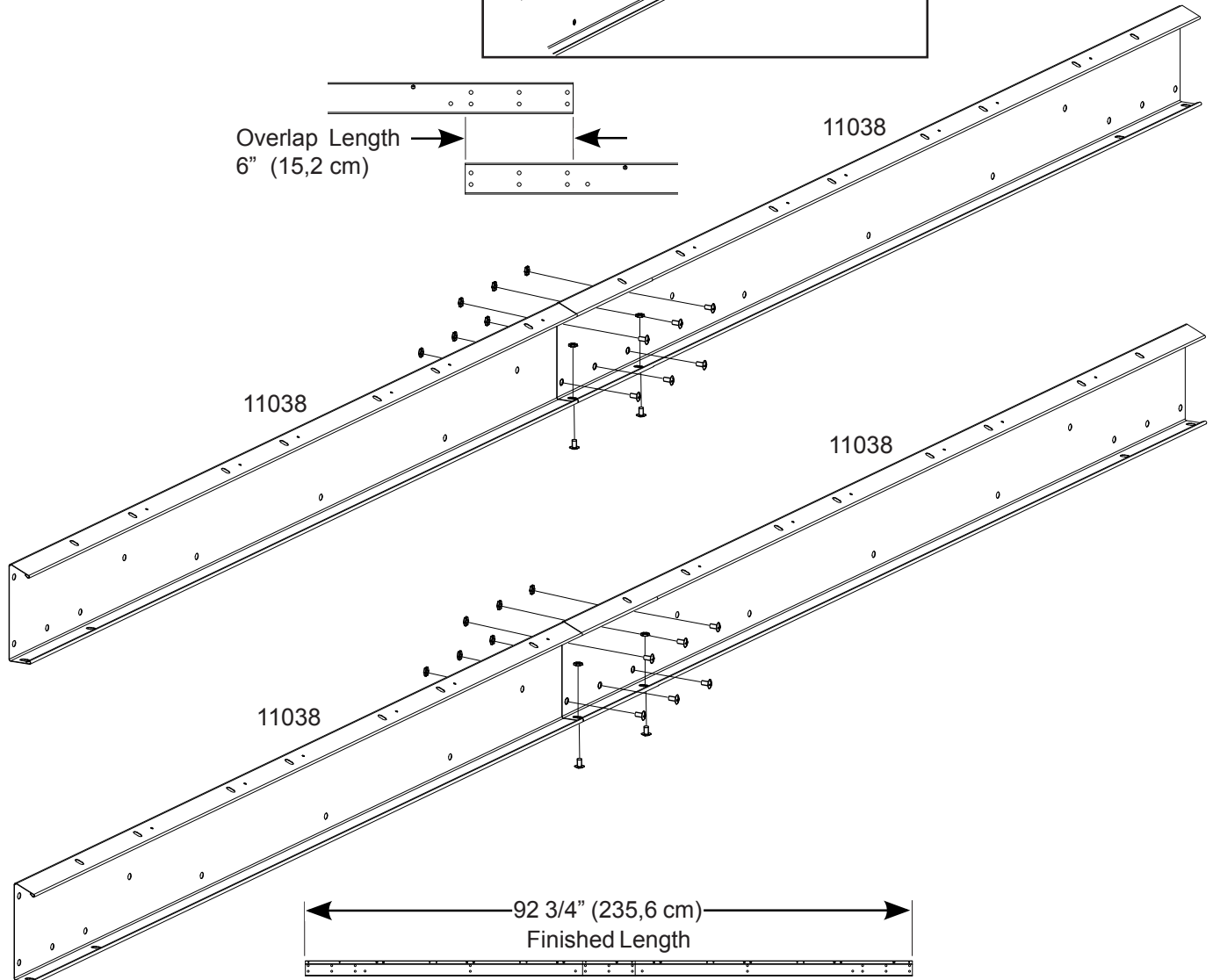

Step 6: Roof pre-assy (2X)

You will need for this page:

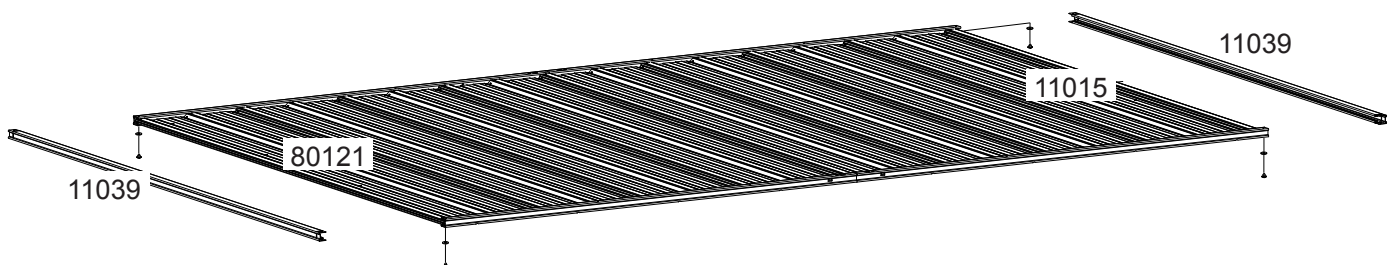
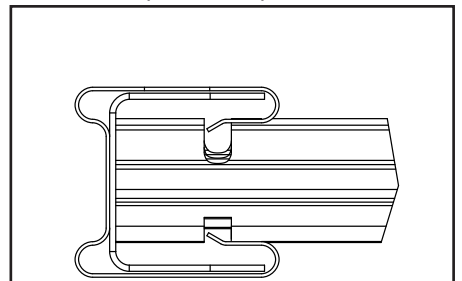
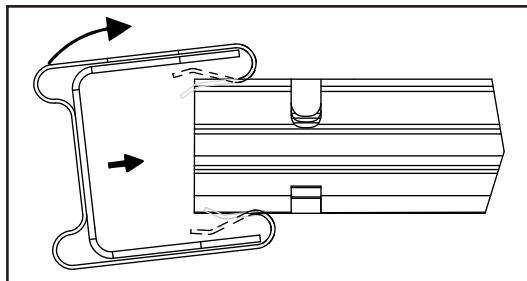
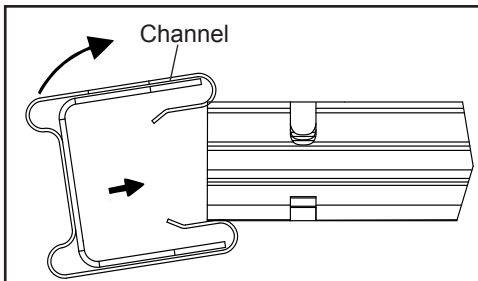
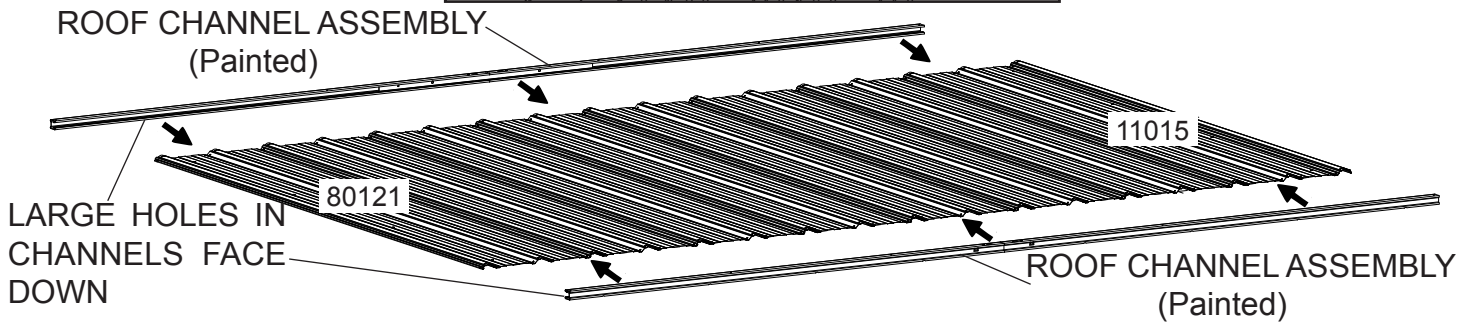
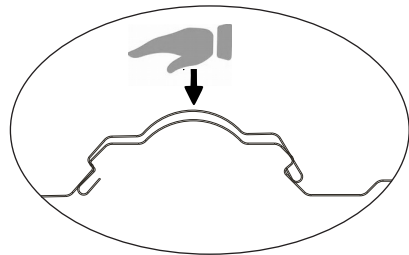
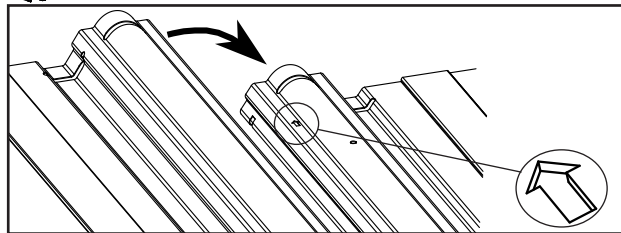
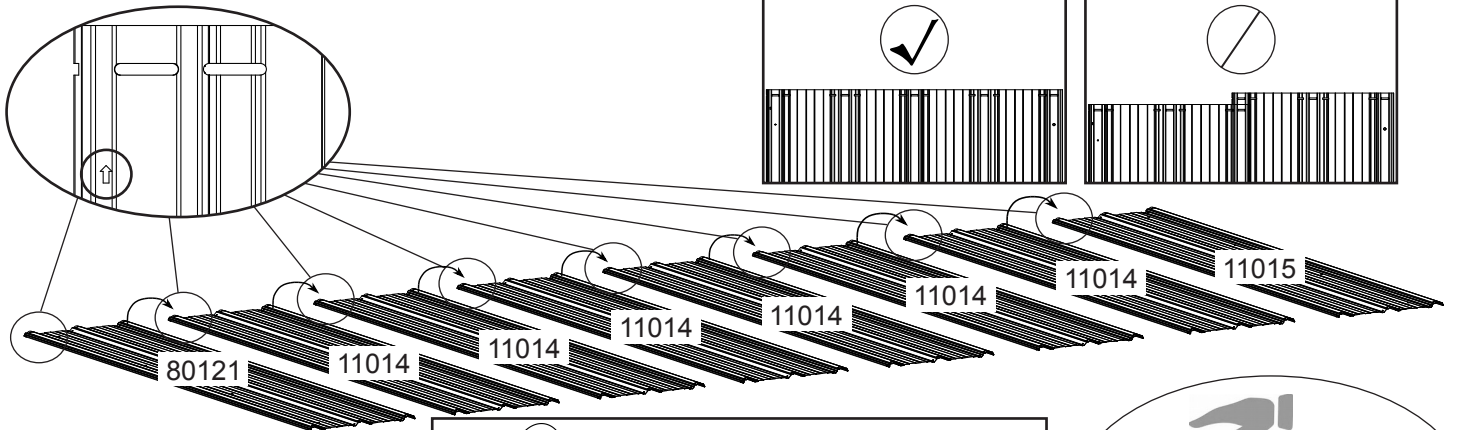
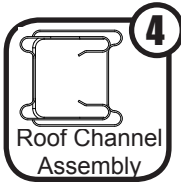
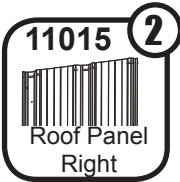
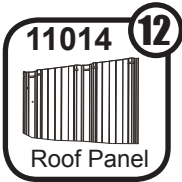
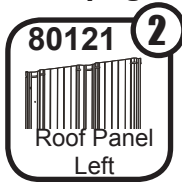
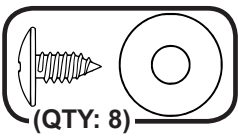

Step 6: Roof pre-assy (2X)

You will need for this page:

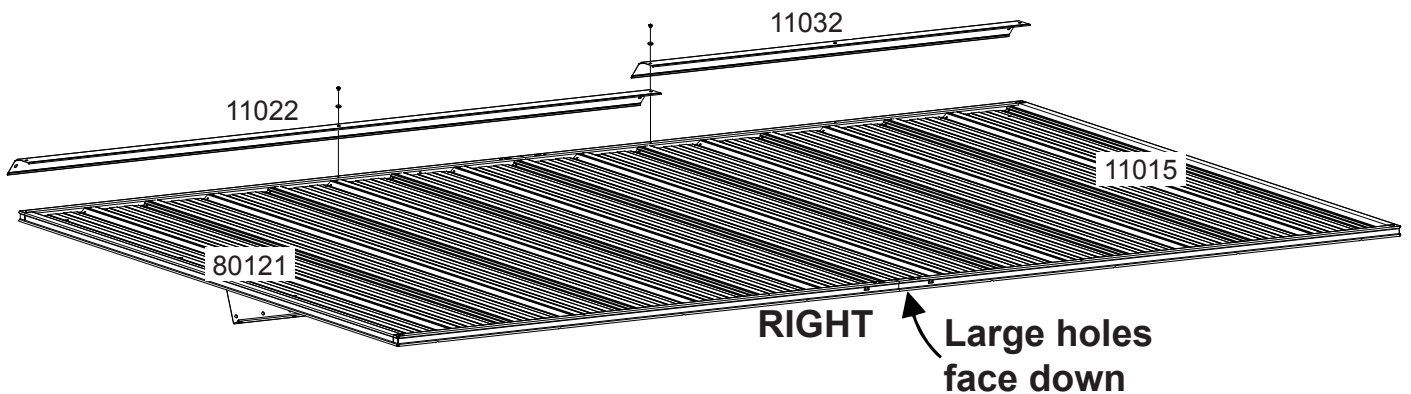
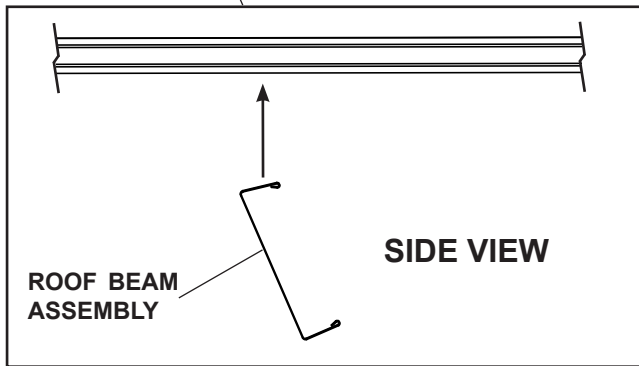
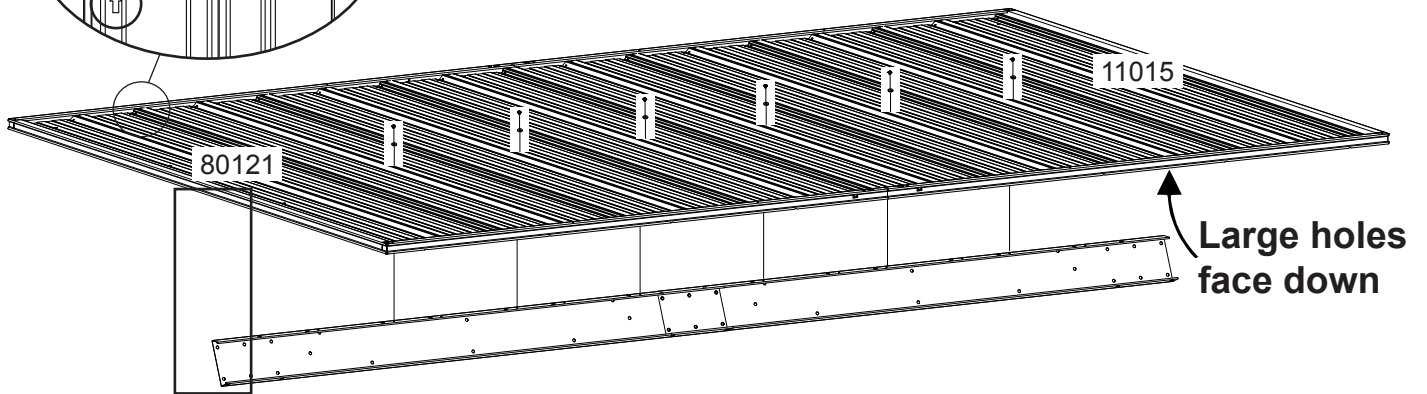
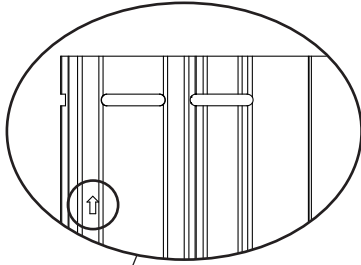
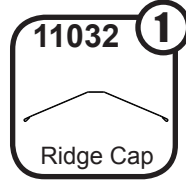
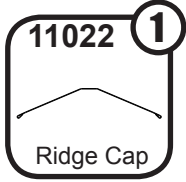
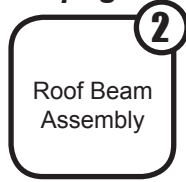
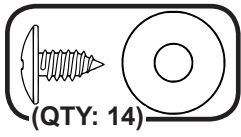

Step 7: Wall Assembly

You will need for this page:

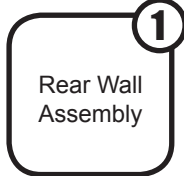
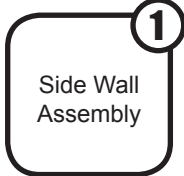
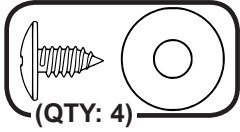

CORNER PANEL ON TOP OF WALL PANEL

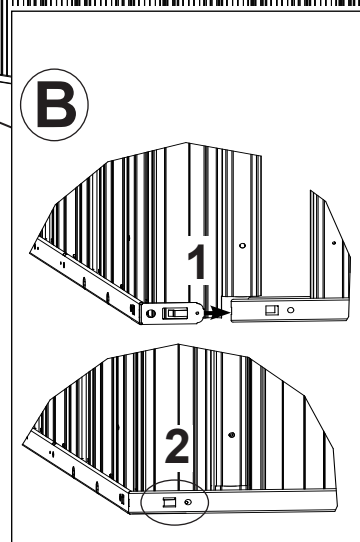
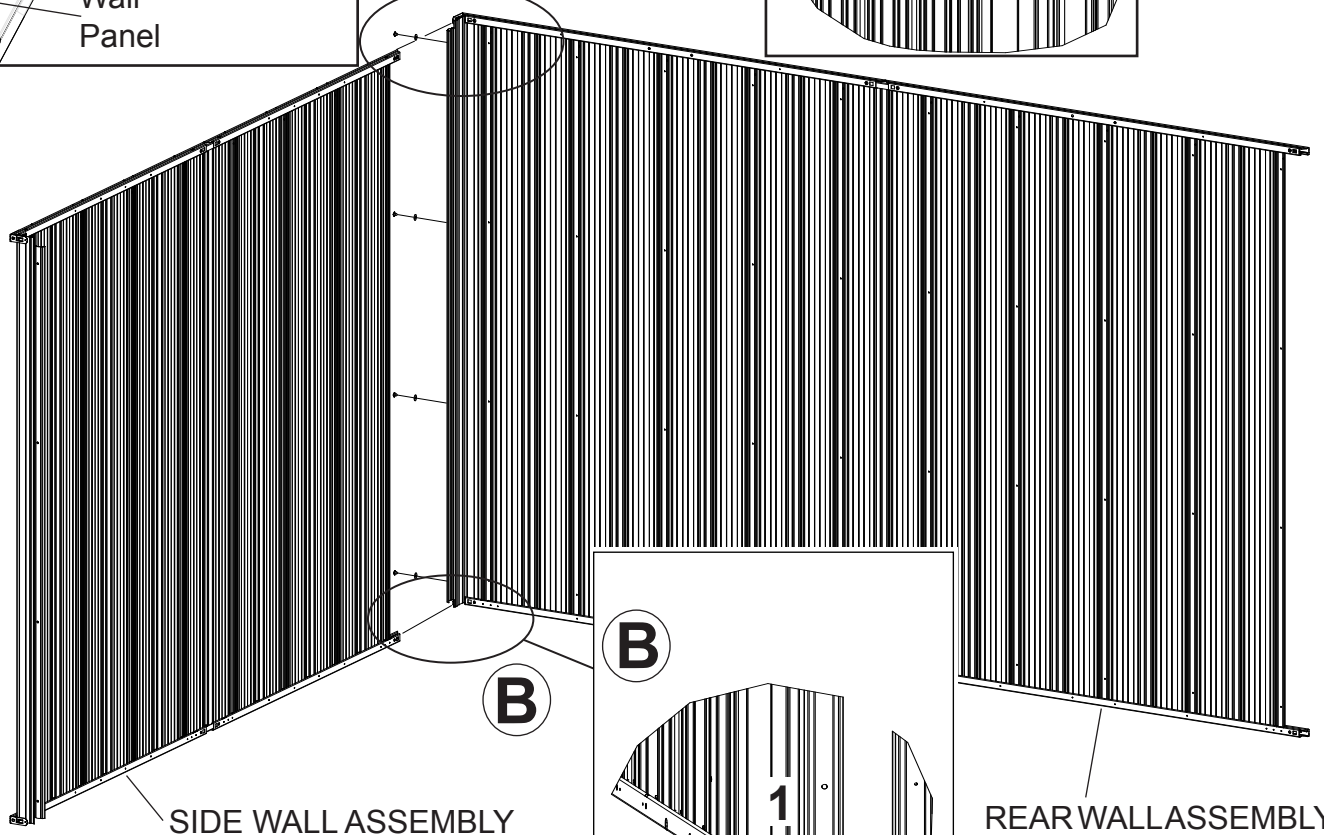
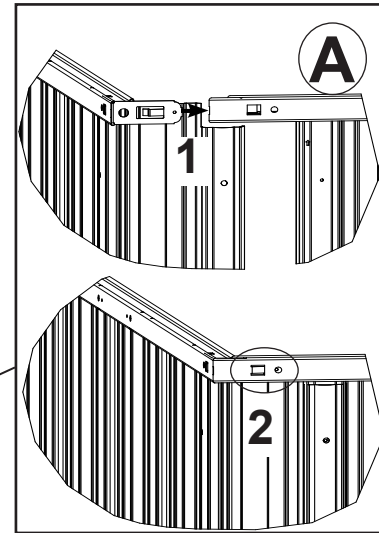
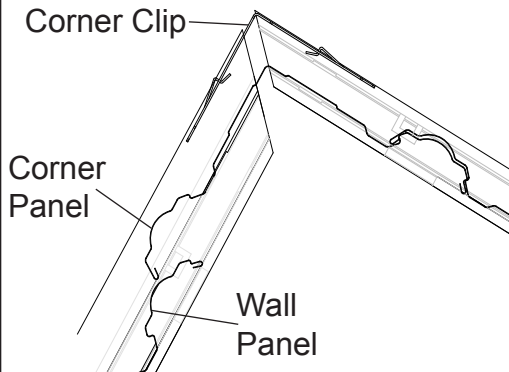

Step 7: Wall Assembly

You will need for this page:

1

Side Wall Assembly

1

Front Wall Assembly

CORNER PANEL ON TOP OF WALL PANEL

Corner Clip

Corner Panel

Wall Panel

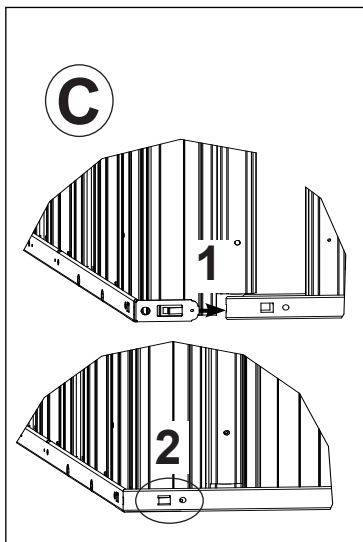
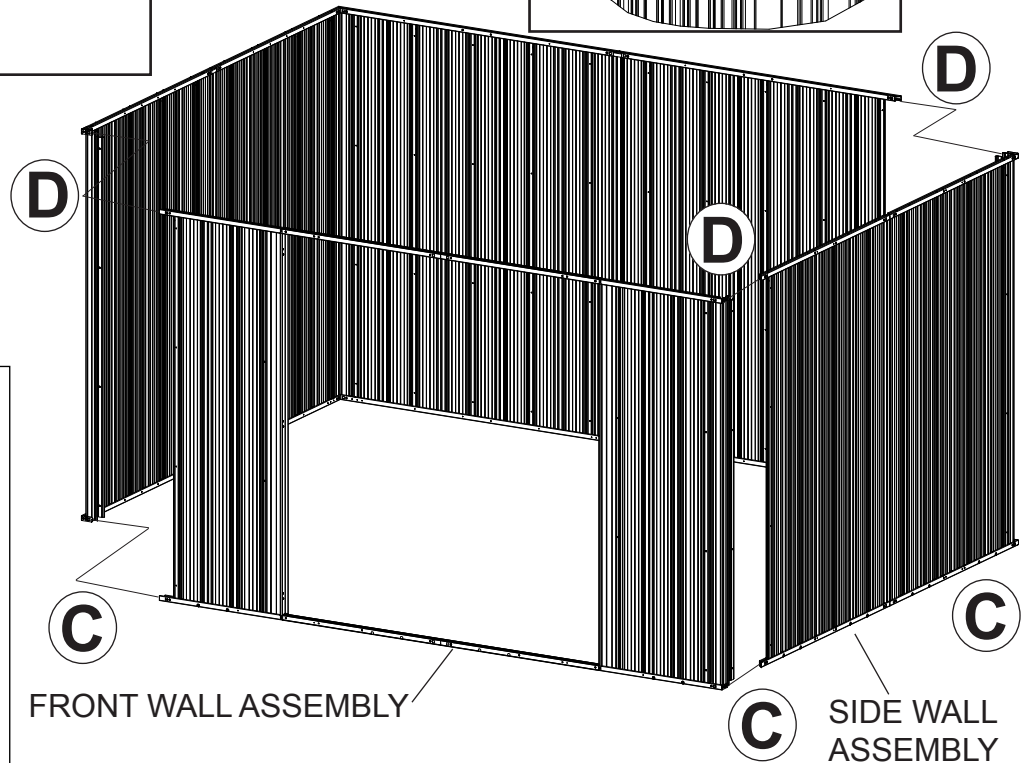
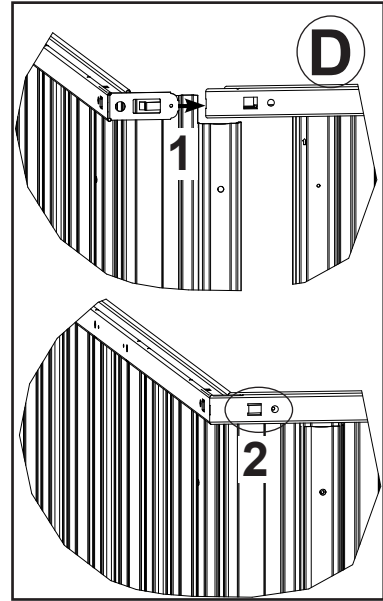

Step 7: Wall Assembly

You will need for this page:

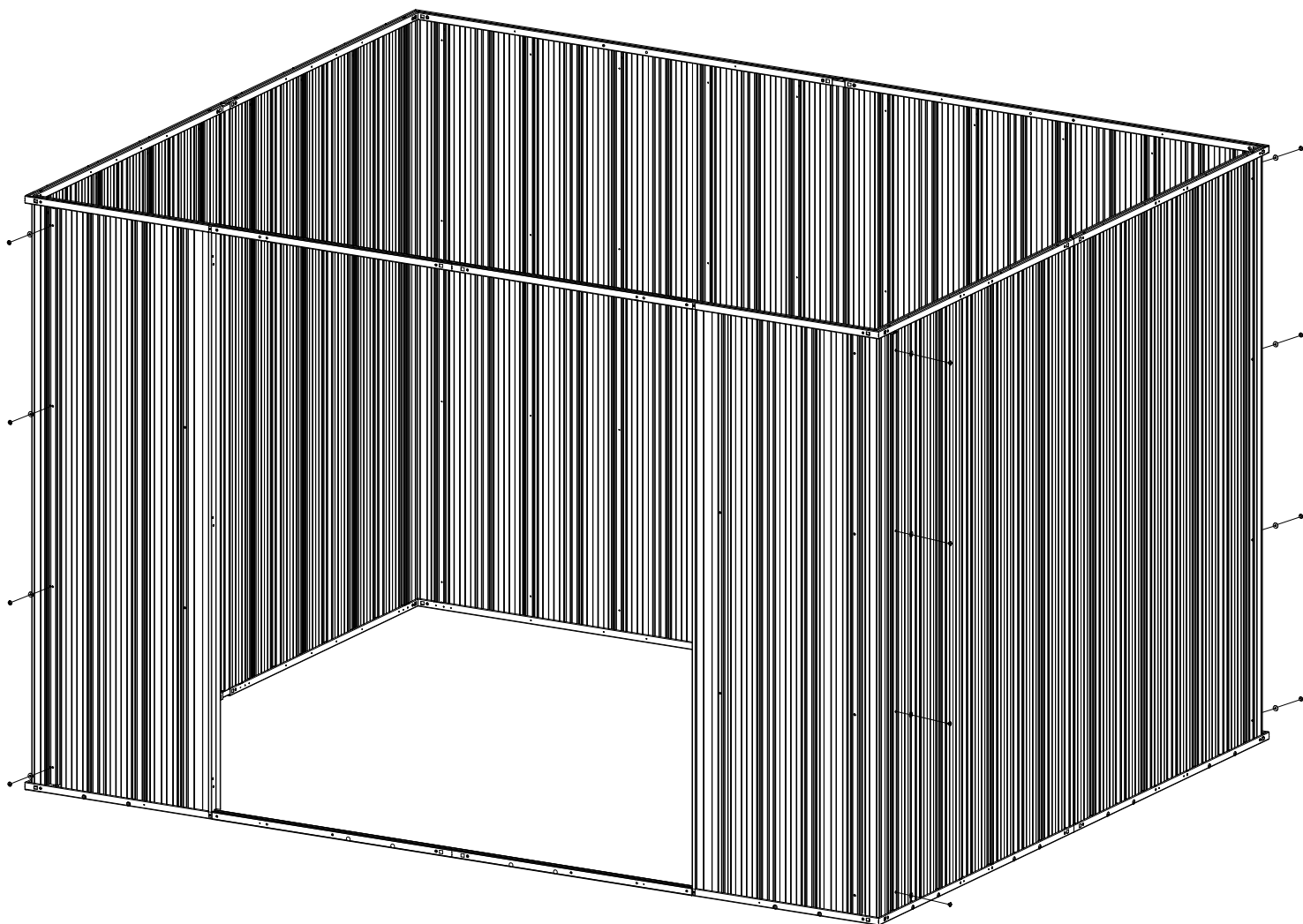
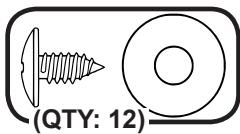

Step 8: Gable & Beam Assy

You will need for this page:

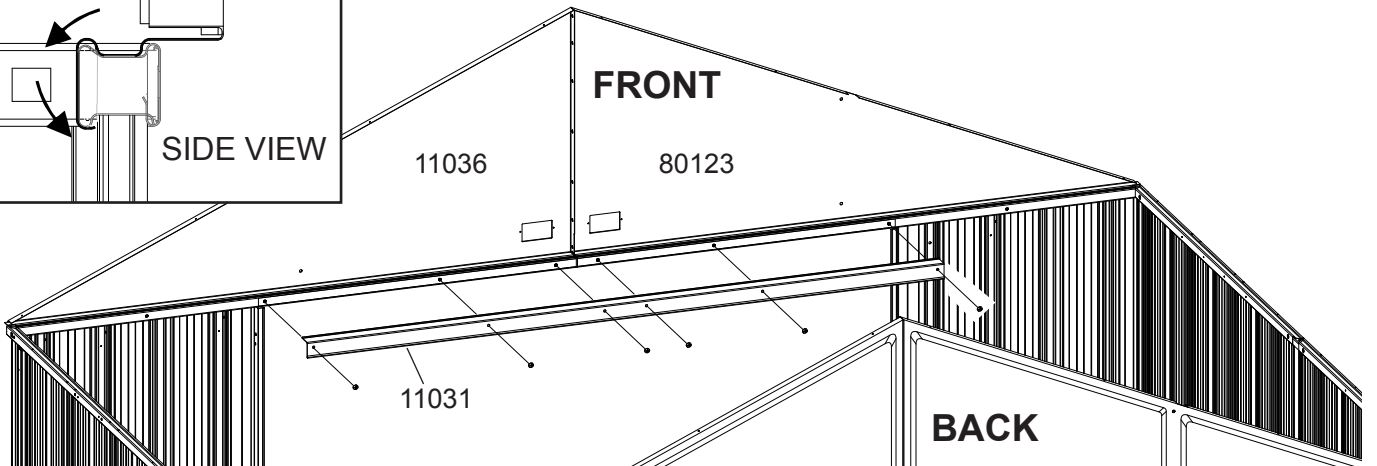
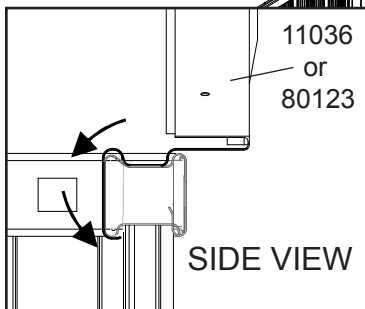
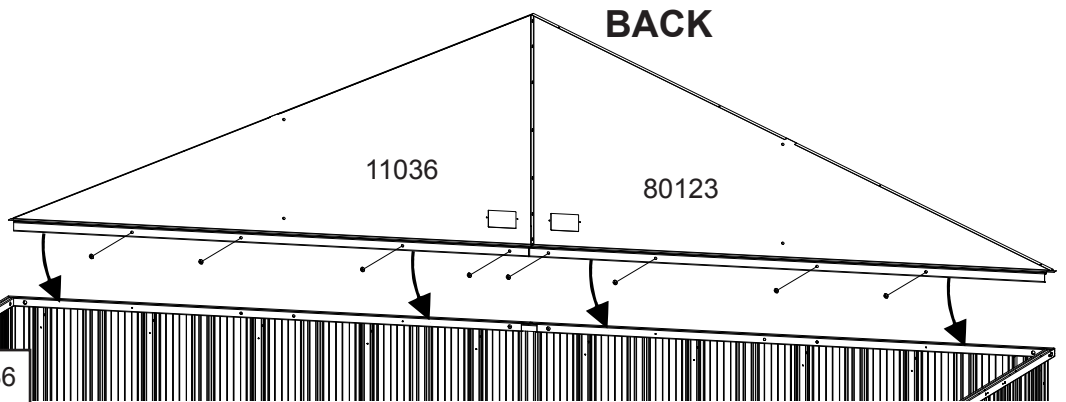
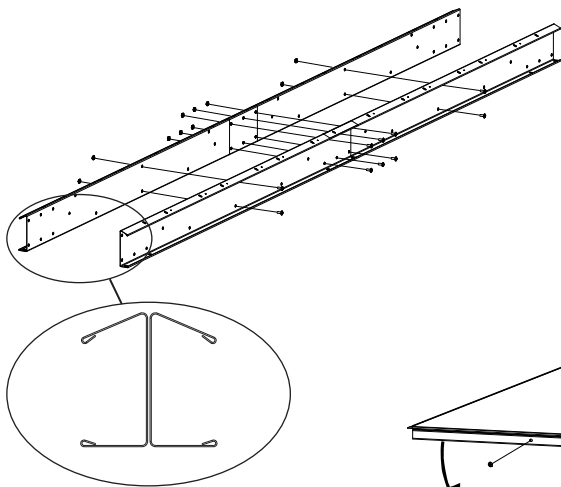
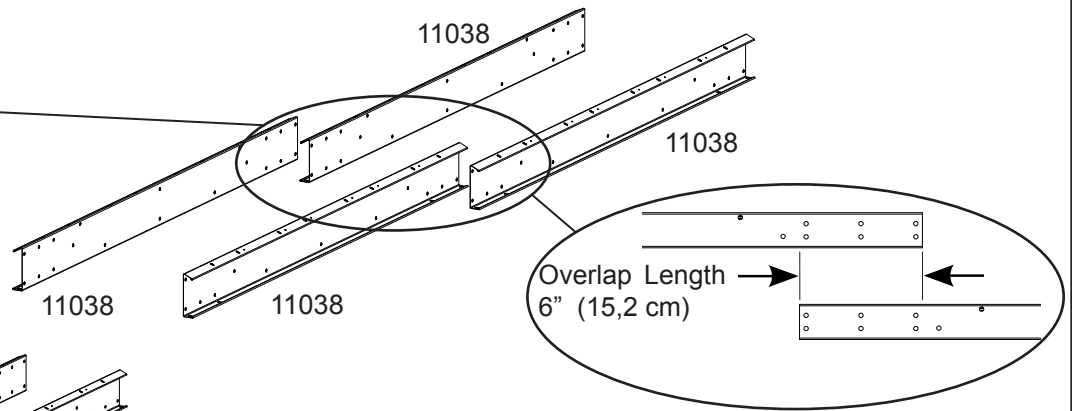
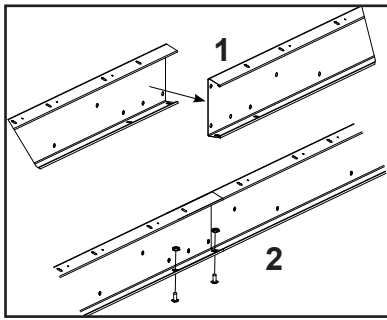
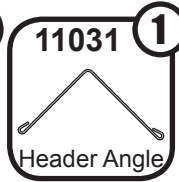
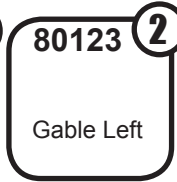
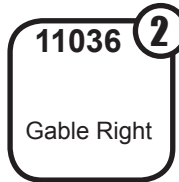
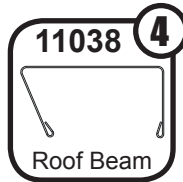
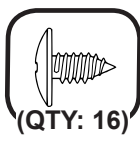
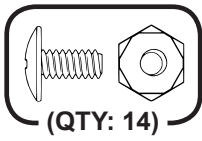

Step 8: Gable & Beam Assy

You will need for this page:

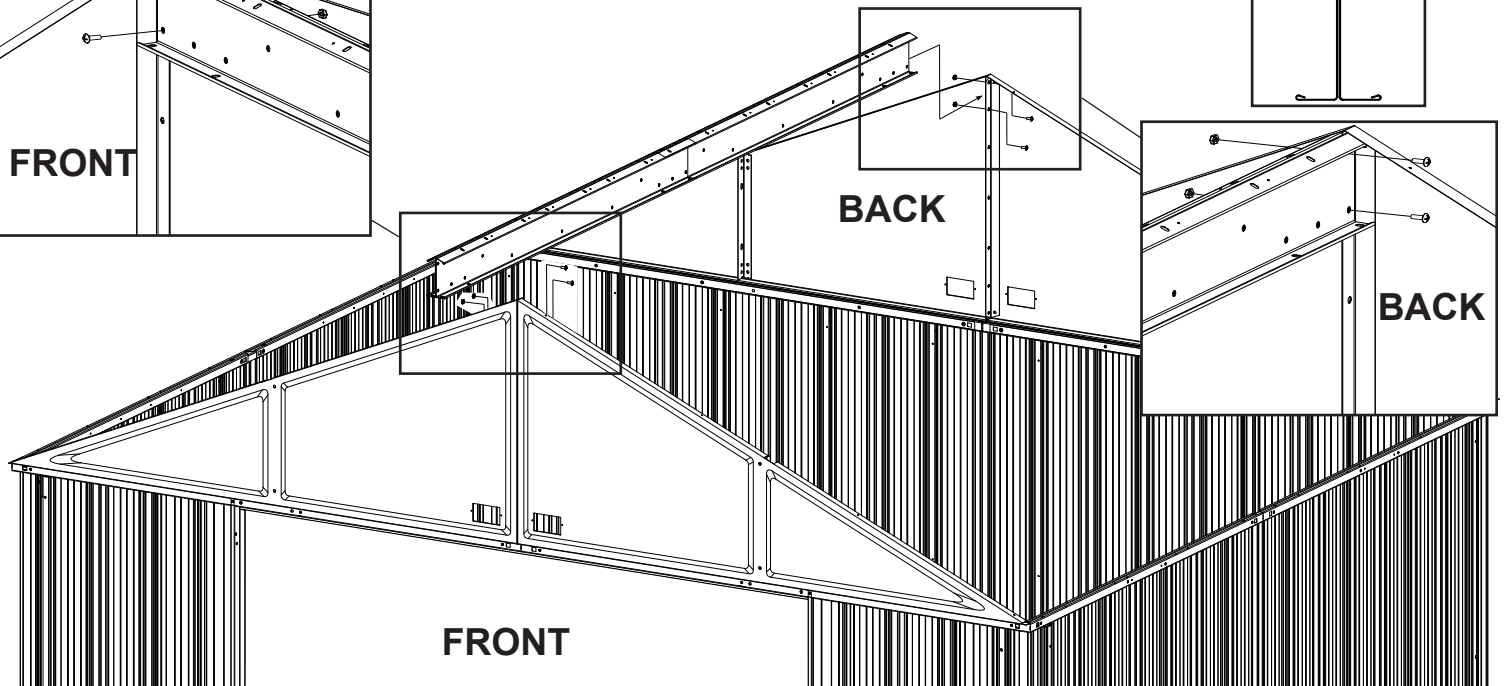
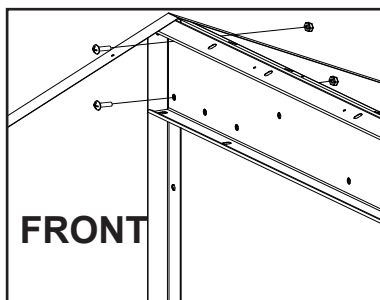
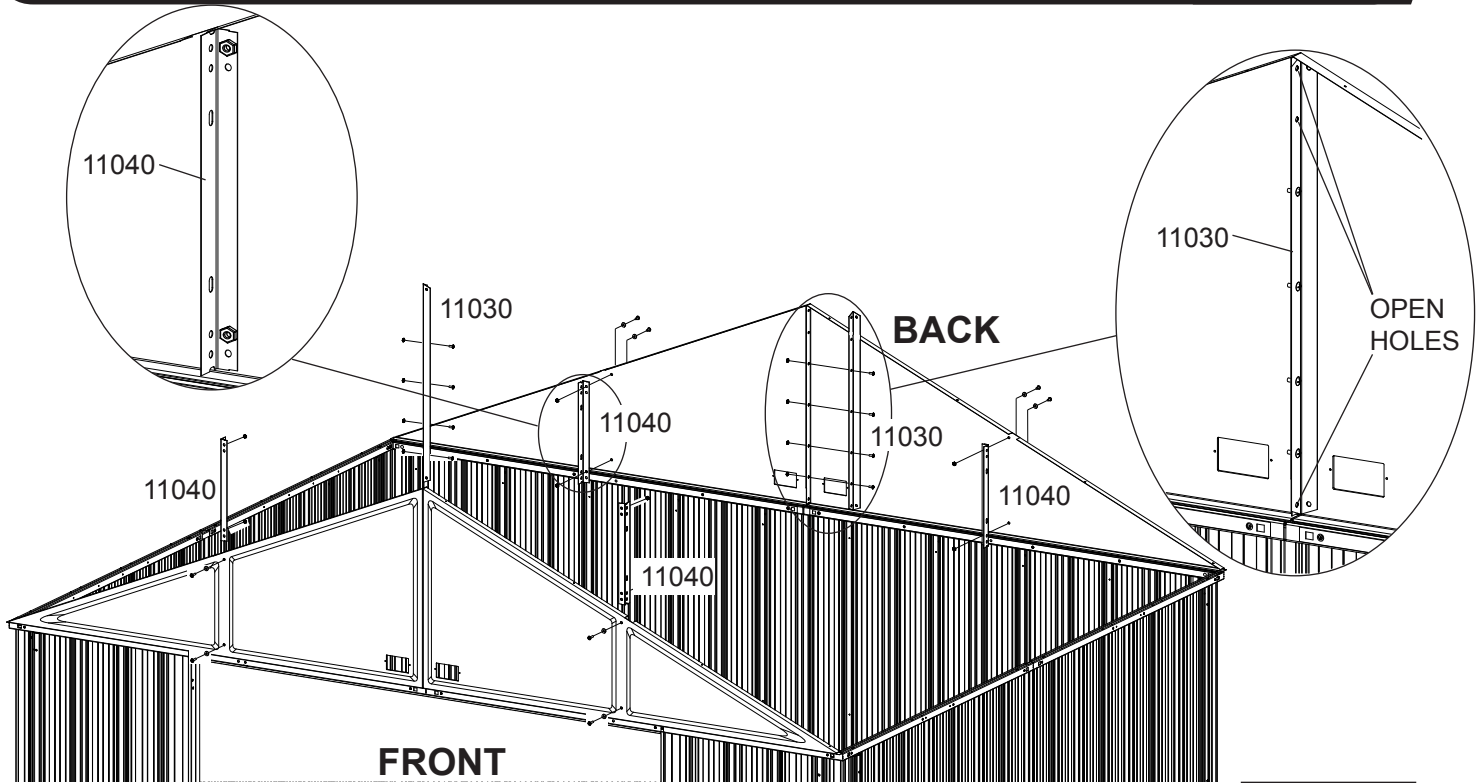
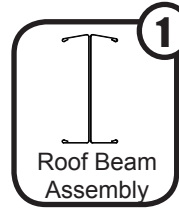
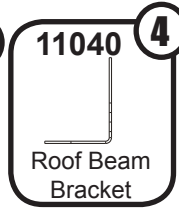
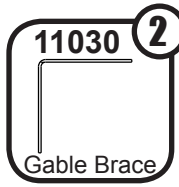
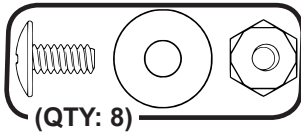
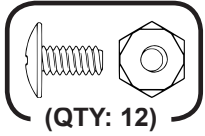

Step 9: Roof Assembly

You will need for this page:

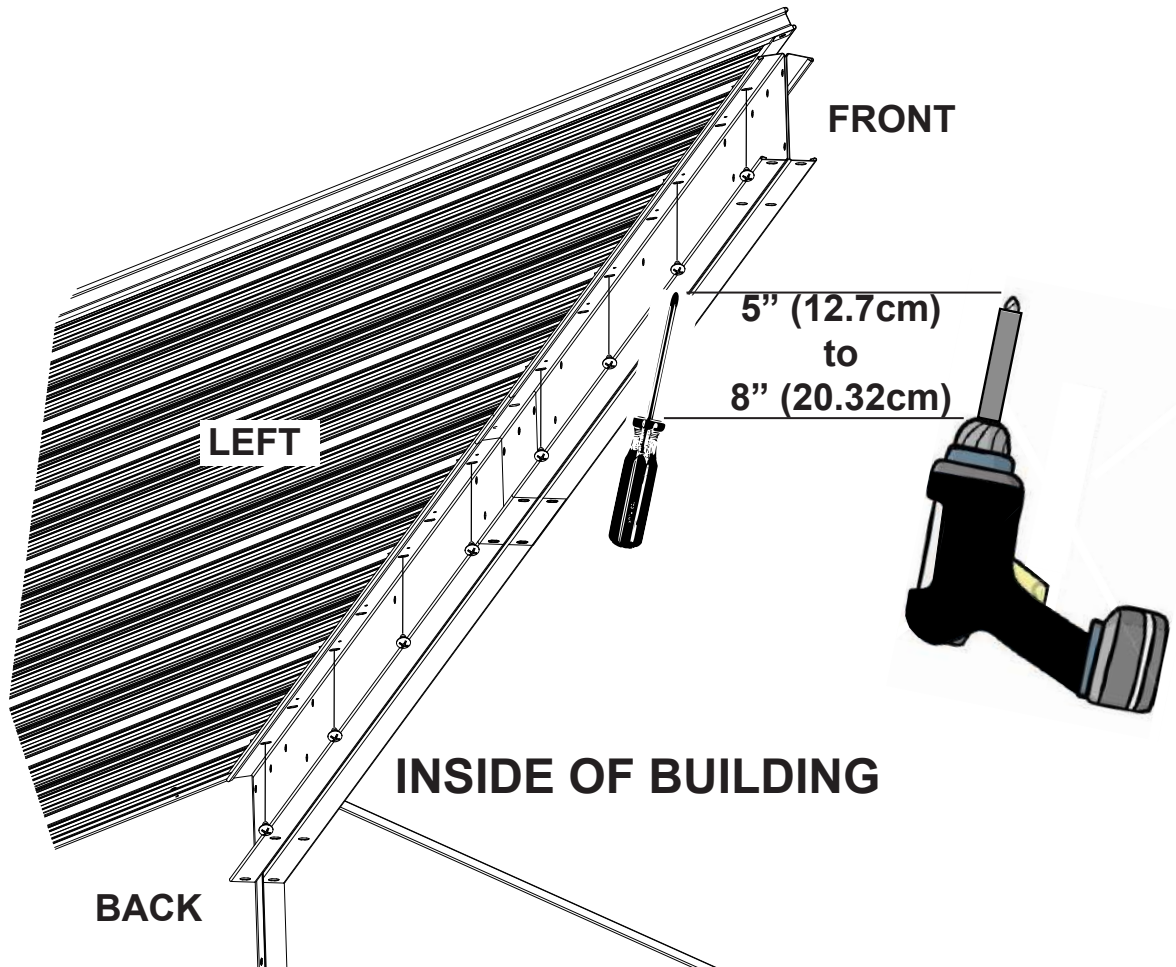
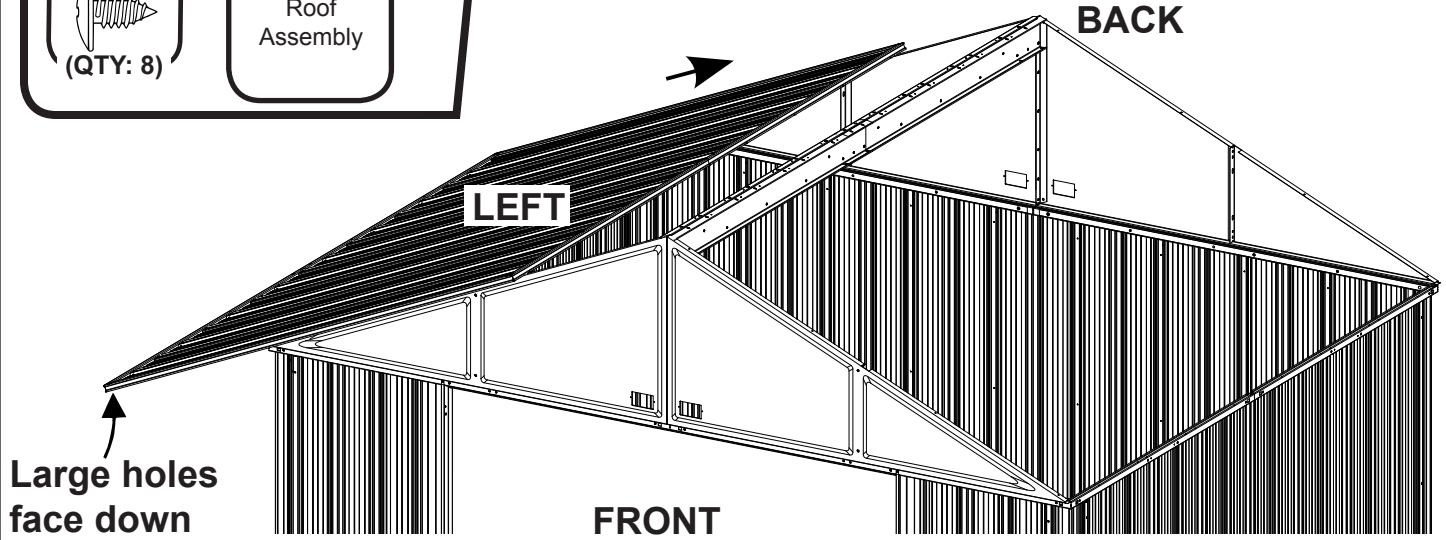
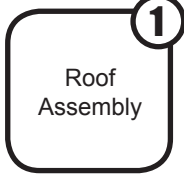

Step 9: Roof Assembly

You will need for this page:

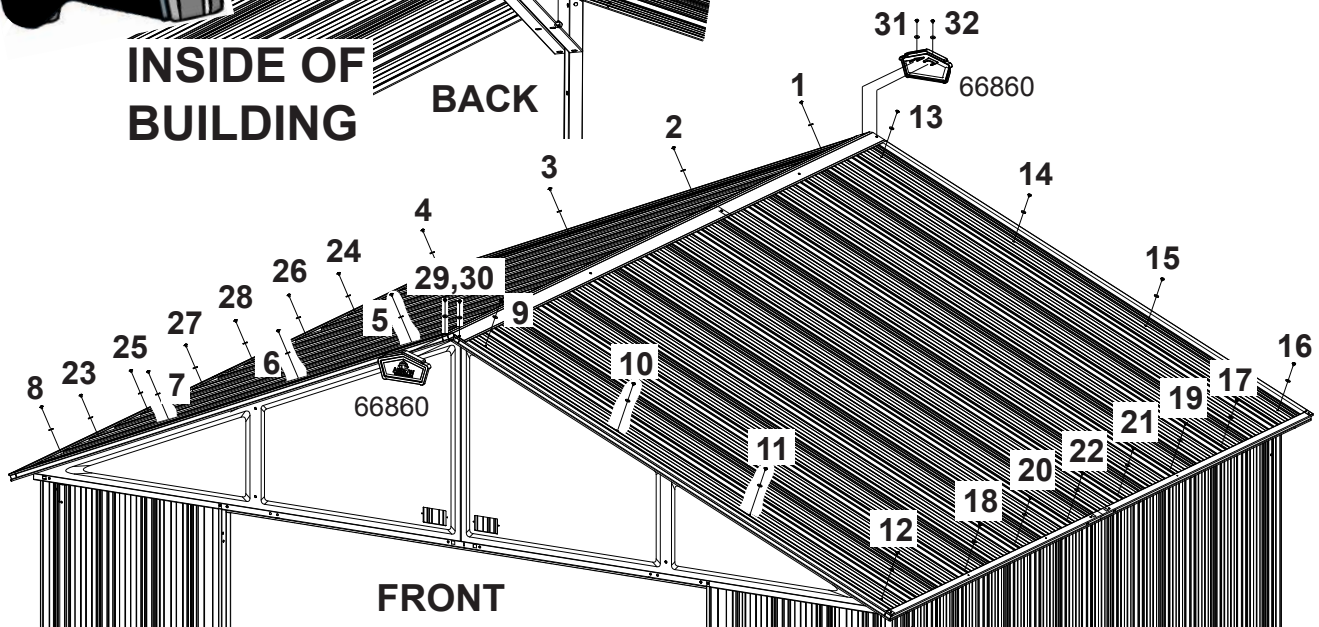
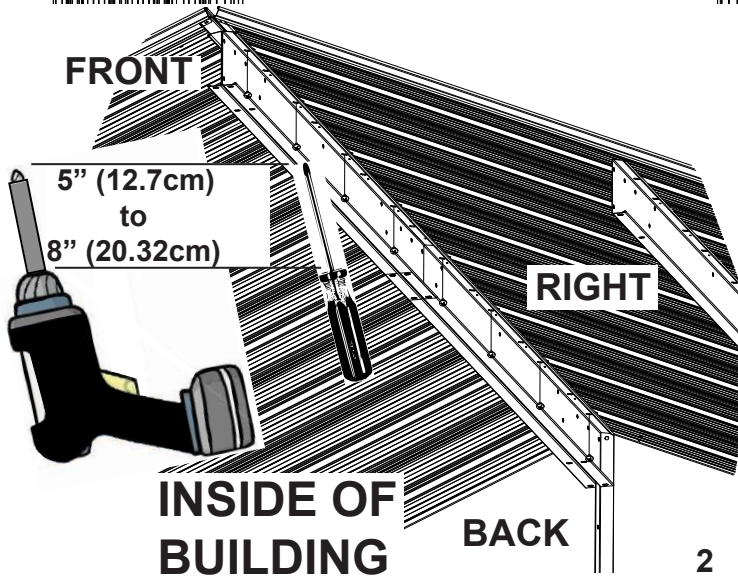
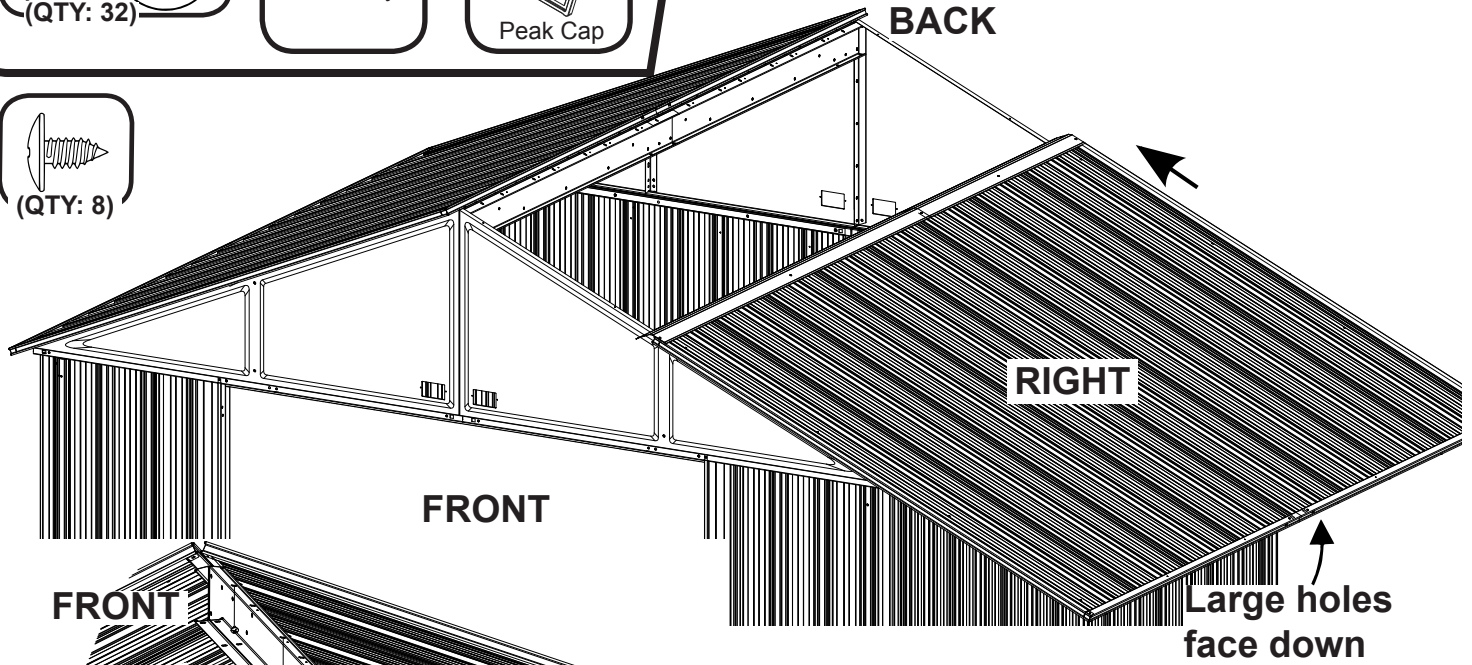
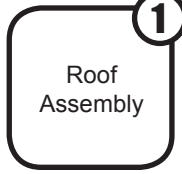
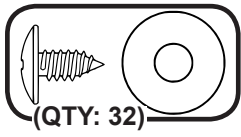

Step 9: Roof Assembly

You will need for this page:

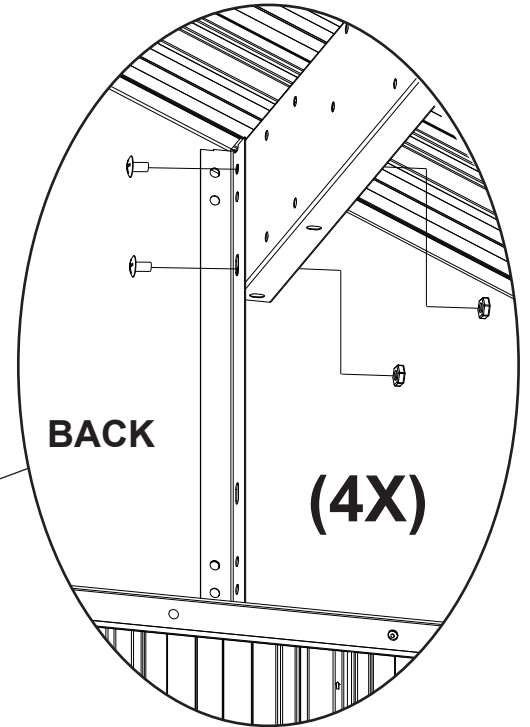
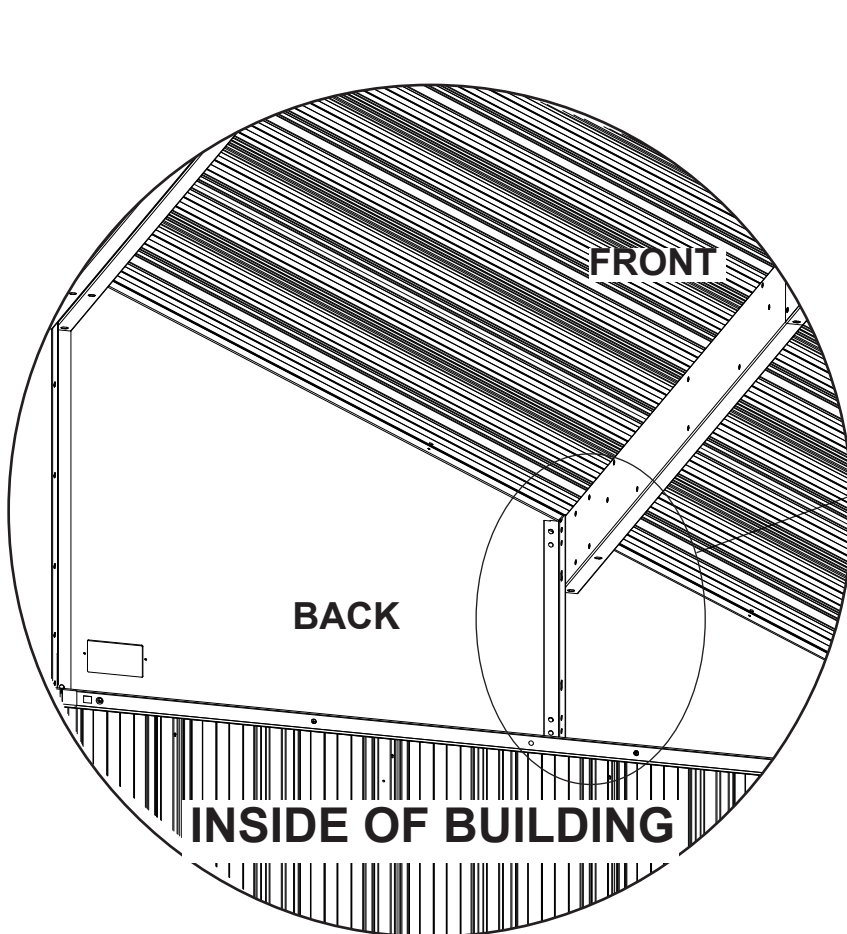
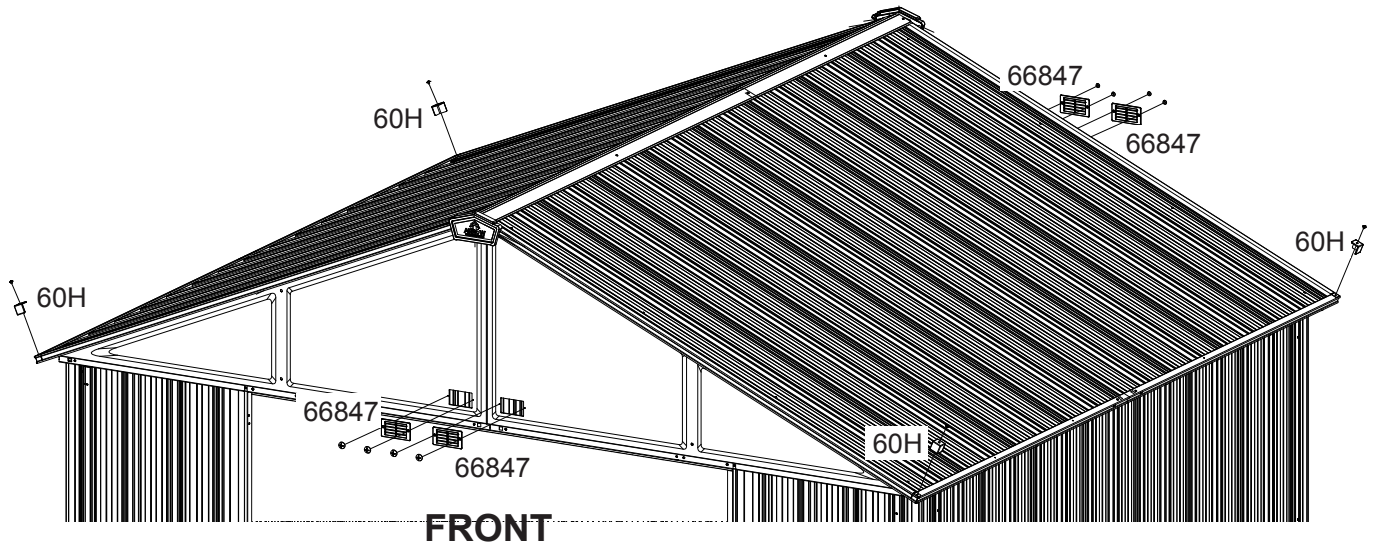
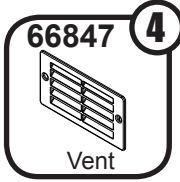
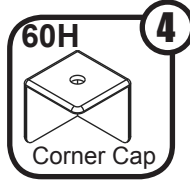
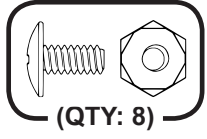

Step 9: Roof Assembly

You will need for this page:

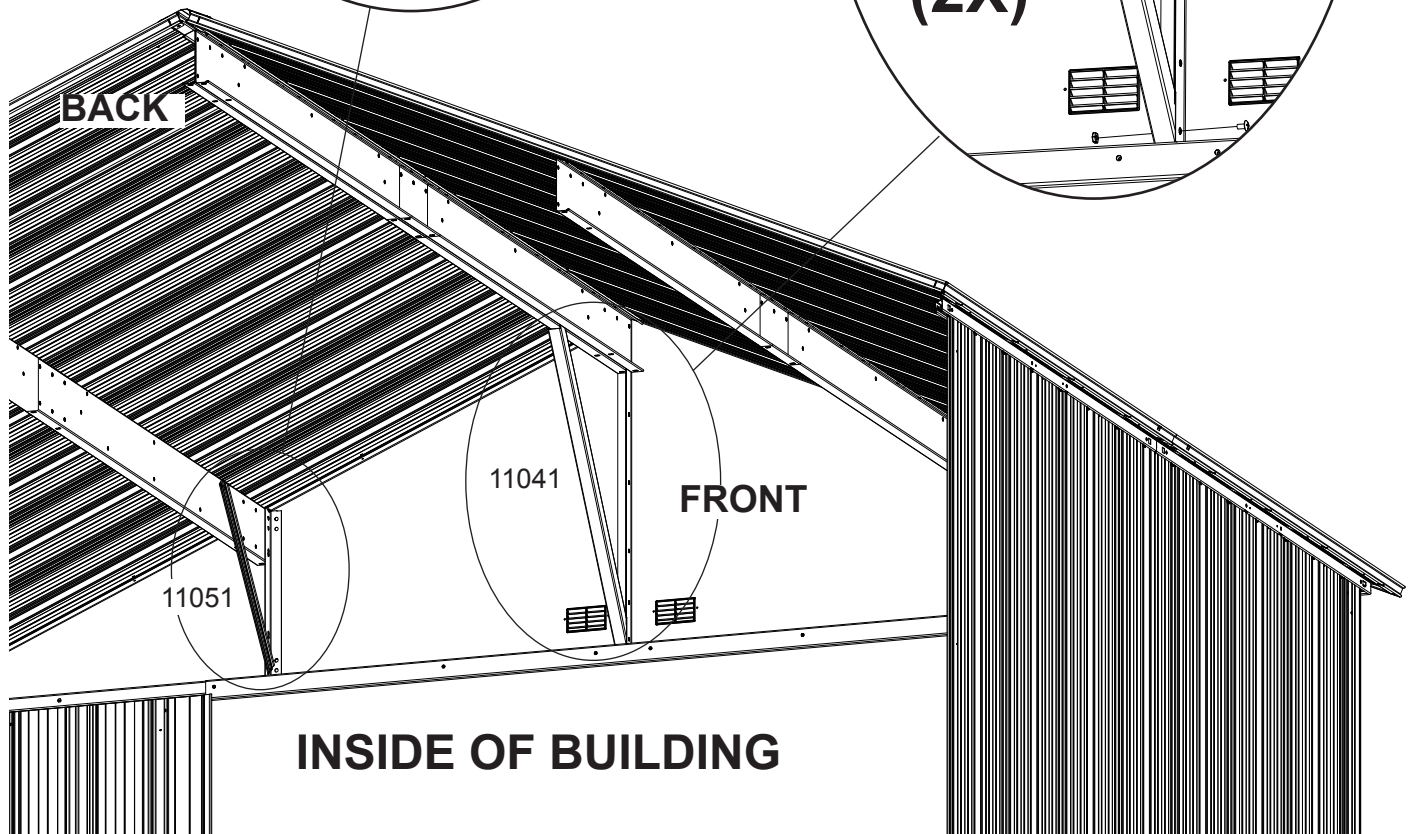
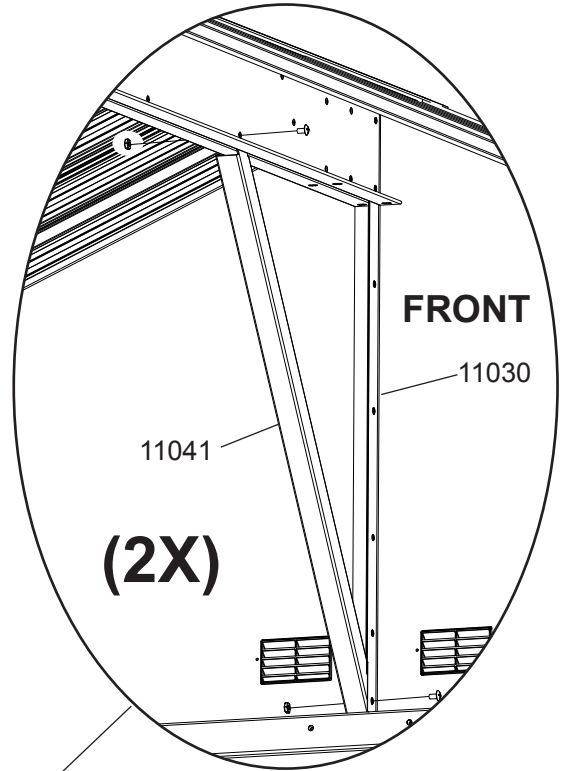
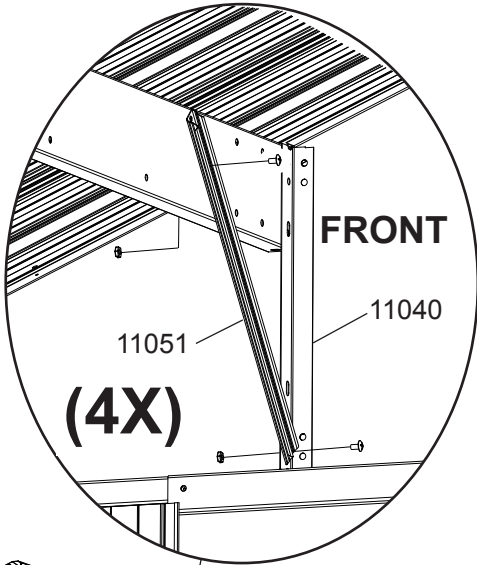
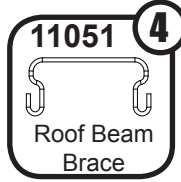
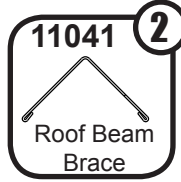
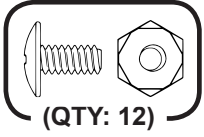

Step 10: Door Assembly

You will need for this page:

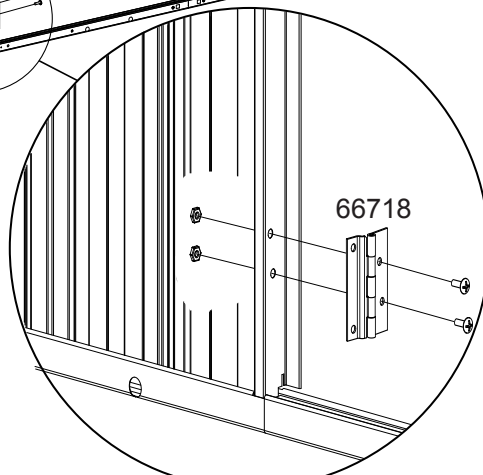
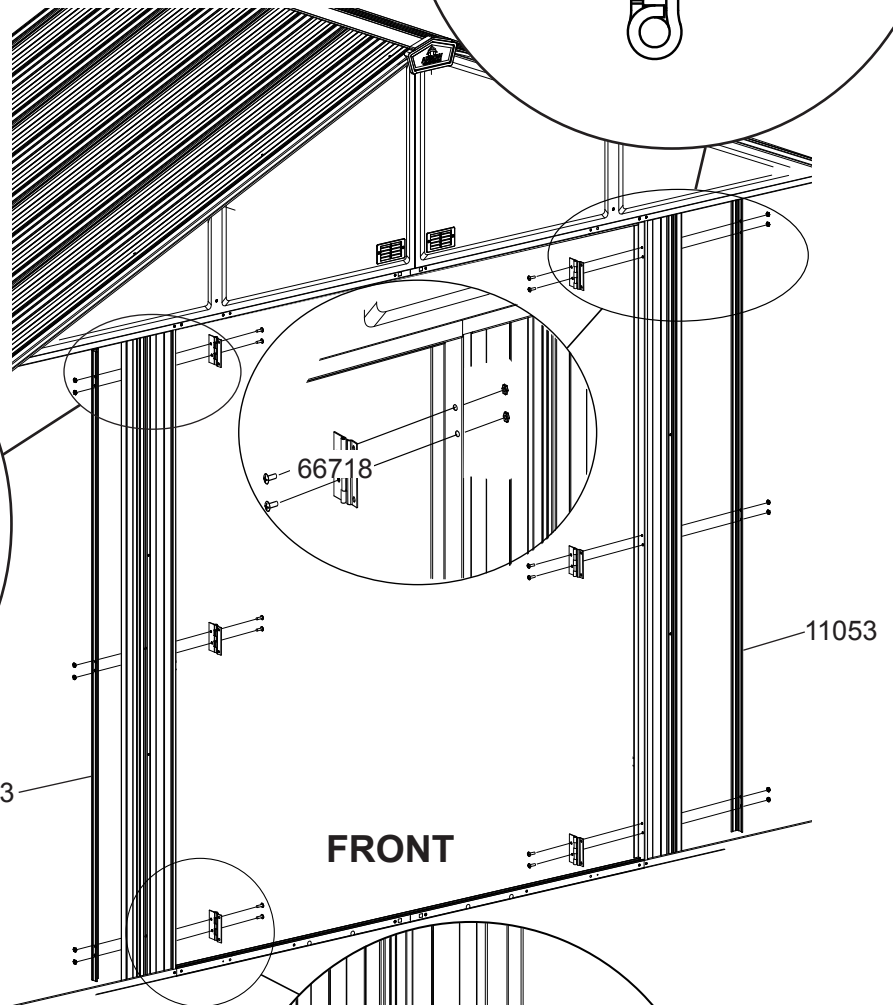
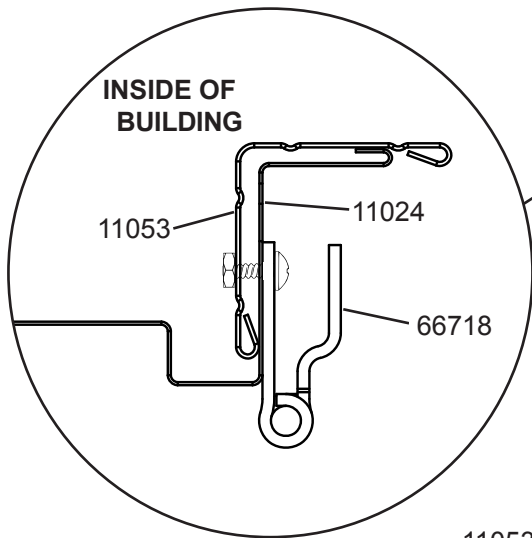
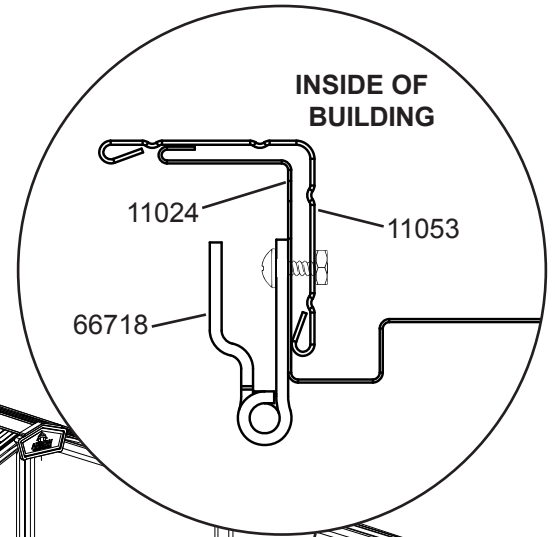
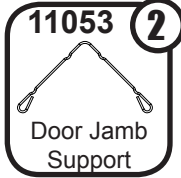
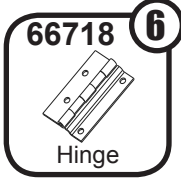
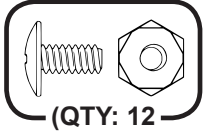

Step 10: Door Assembly

You will need for this page:



1

Right Door
Assembly

1

Left Door
Assembly

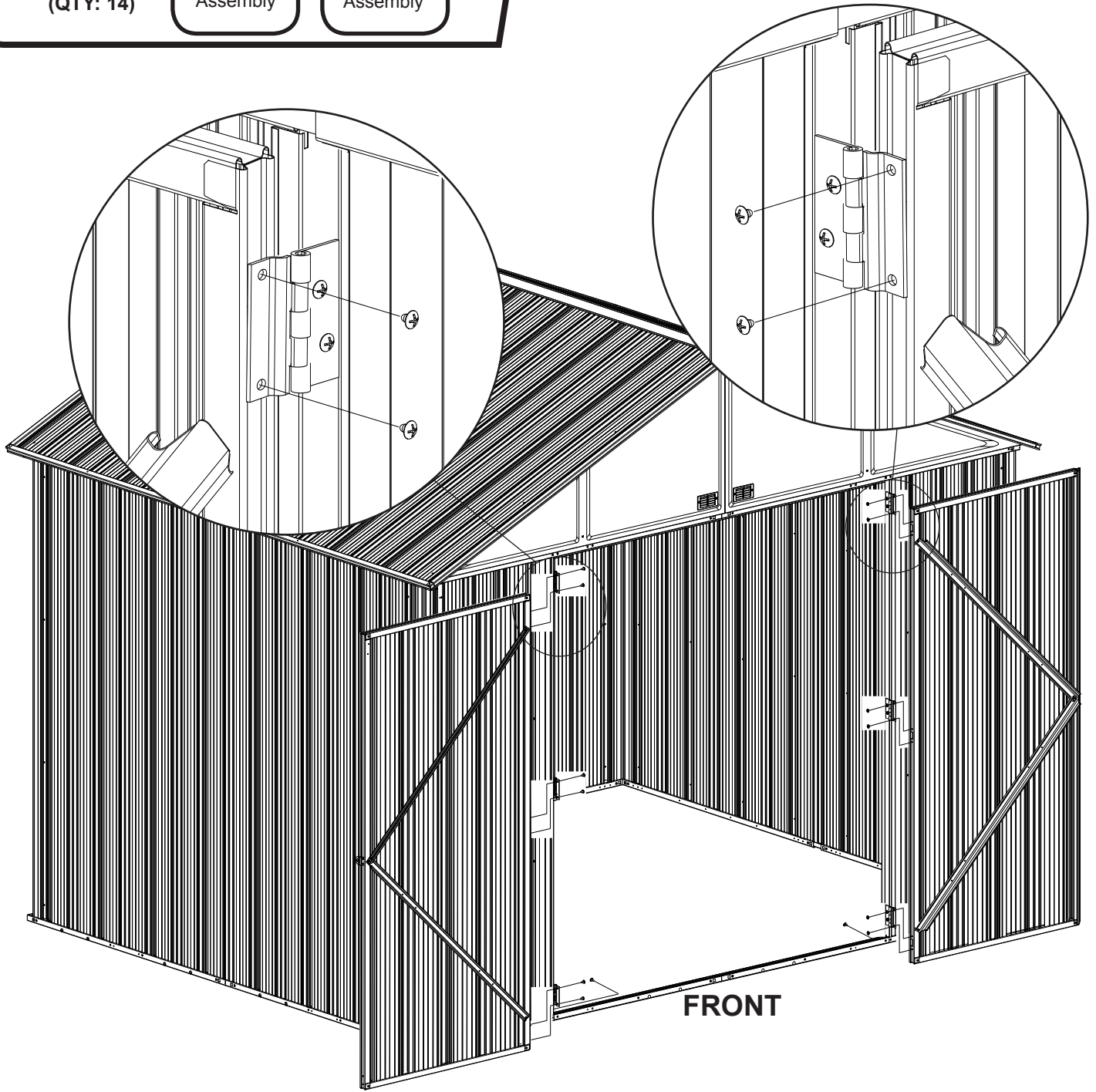

ARROW ACCESSORIES...

ANCHOR KITS

Model No. AK4

Anchor Kit contains heavy-duty steel augers, 60' (18 m) of steel cable and 4 cable clamps. No digging or concrete pouring, just insert cable under roof, over roof beams, into augers and twist augers into the ground. For buildings larger than 10'x9' (3,0 m x 2,6 m), use 2 kits.

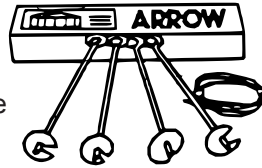

See Page. 50

Model No. AK100

New concrete anchor system permits anchoring any size Arrow building directly to a concrete slab. Each kit contains heavy-duty, hot-dipped galvanized steel corner gussets and perimeter clips which fit over the floor frame and lag bolt into a concrete slab. Full assembly instructions and a 1/4" masonry drill bit are included.

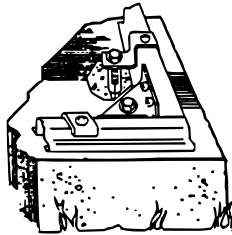

See Page. 50

FLOOR FRAME KITS

MODELS FKEZEE

A simple floor frame system made of heavy-duty, hot-dipped galvanized steel. Use as base for plywood, sand or stone.

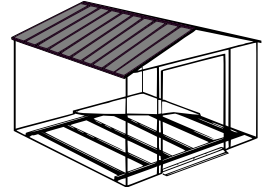

Model No. AK600

Earth Anchor Kit anchors any size Arrow building to the ground. Each kit contains heavy duty, hot-dipped galvanized steel corner gussets and 4 earth anchors.

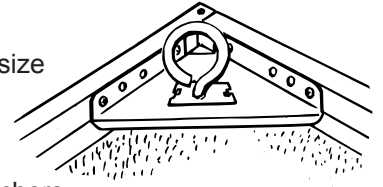

SPECIAL NOTICE ON DELIVERY:

If your accessory is shipped via truck line a day time phone number is required to arrange delivery. If no one is available to sign for the delivery, you may be subject to a re-delivery charge assessed by the carrier.

ANCHORING OPTIONS...

IMPORTANT:

It is important that building be anchored after construction. These are recommended ways of anchoring.

Arrow Anchoring Kit: (Model No. AK100)
Recommended for use with the **concrete** base.
Contains: Corner gussets, perimeter clips, hardware, 1/4" masonry drill bit and installation instructions.

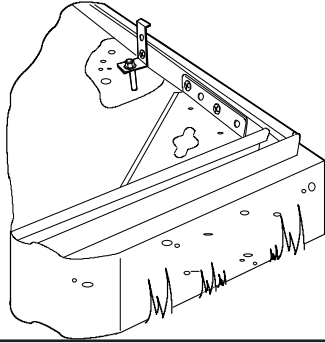

Anchor into Wood or Concrete
For wood platform. Use Decking Screws.
For concrete slab. Use Lag Screws.

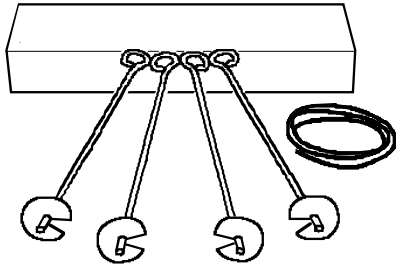
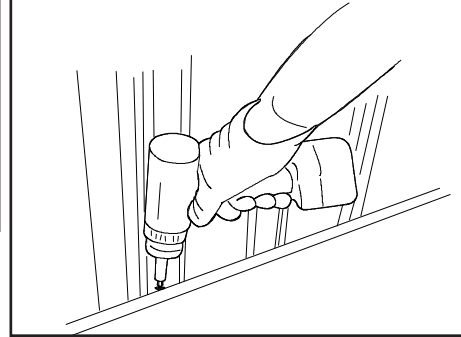

Arrow Anchoring Kit: (Model No. AK4)
Recommended for use with **any** suggested base.
Contains: 4 Anchors with Cable, Clamps and installation instructions.

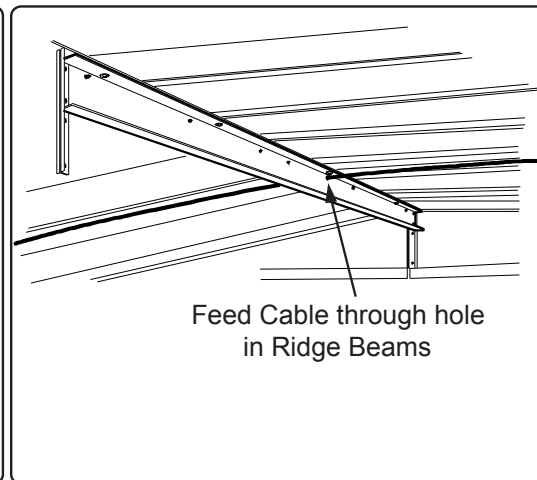
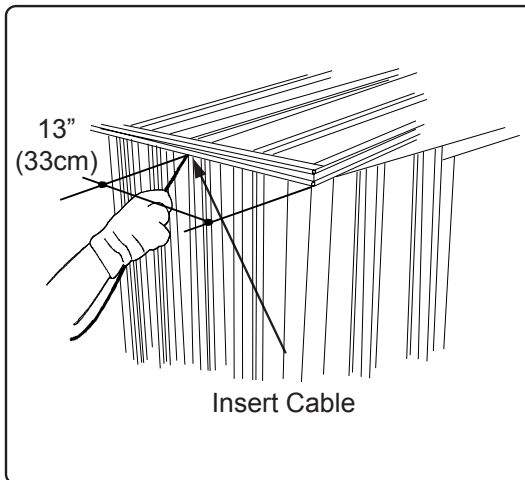

Turn Anchors into ground
close to building and
attach Cable