

# Owner's Manual & Assembly Guide



INNOVATION UNDER COVER<sup>®</sup>

**caution**  
sharp edges \*

Gloves must be worn at all times to reduce risk of injury!

\* See Inside for Detailed Safety Information.

# COMMANDER™ SERIES MOUNTAINEER™ SERIES

Model No. CHD1010-A

MHD1010-A

All Sizes

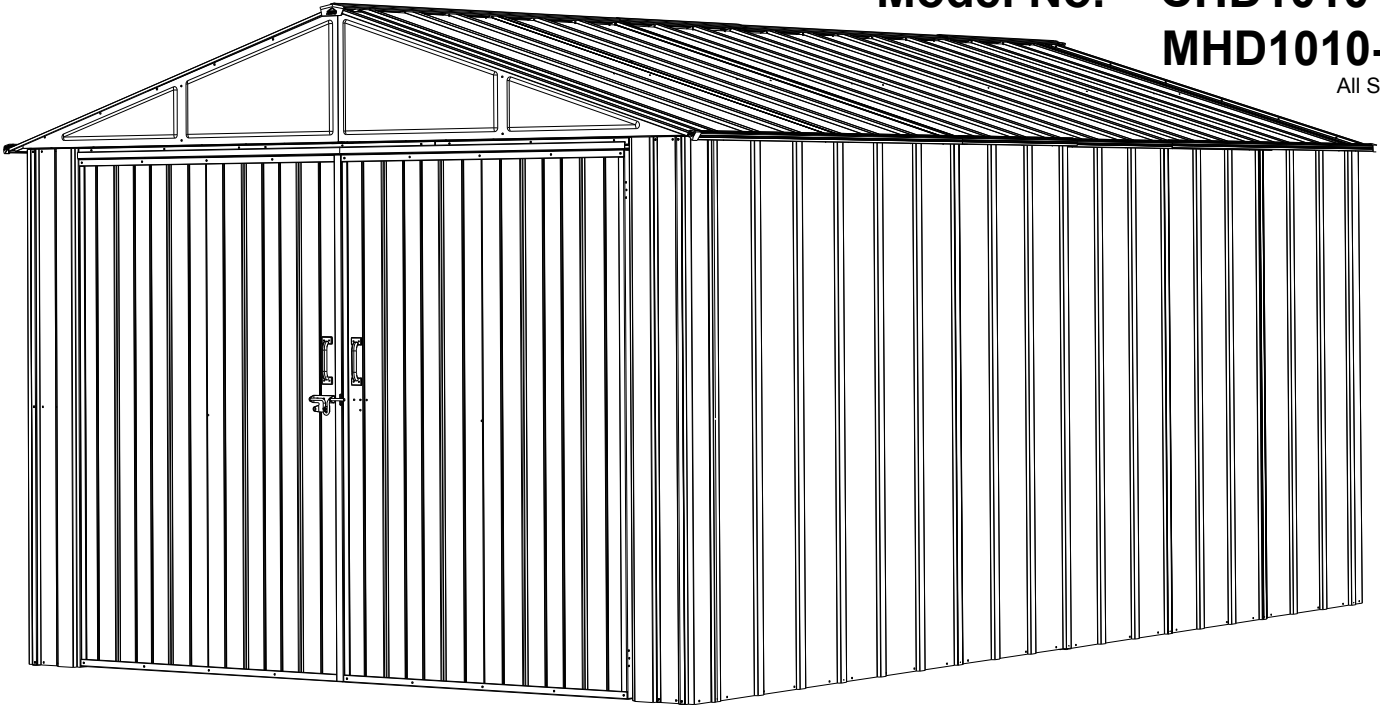

<b>10x10 Base Size</b>	122 1/4" x 127 1/2" 310,5 cm x 323,9 cm
<b>Additional per Module</b>	122 1/4" x 57 1/2" 310,5 cm x 146,1 cm

**BASE BUILDING DIMENSIONS**

† Size rounded off to the nearest foot

For proper base construction see page 5

Approx. † Size	Storage Area	Storage Volume	Exterior Dimensions (Roof Edge to Roof Edge)			Interior Dimensions (Wall to Wall)			Door Opening	
			Width	Depth	Height	Width	Depth	Height	Width	Height
10' x 10'	101 Sq. Ft.	697 Cu. Ft.	123 1/4"	128 3/4"	92 1/2"	118 1/4"	123 1/2"	91 1/4"	98 1/4"	72 3/4"
3,0 m x 3,1 m	9,4 m <sup>2</sup>	19,7 m <sup>3</sup>	313,1 cm	327,0 cm	235,0 cm	300,4 cm	313,7 cm	231,8 cm	249,6 cm	184,8 cm

Each Module adds an additional 57 1/2" (146,1 cm) in length, 47.2 Sq. Ft. (4,4 m<sup>2</sup>) additional storage area, and 324 Cu. Ft. (9,2 m<sup>3</sup>) additional storage volume.

# SAFETY PRECAUTIONS...

*Safety precautions MUST be followed at all times throughout the construction of your building!*

## sharp edges

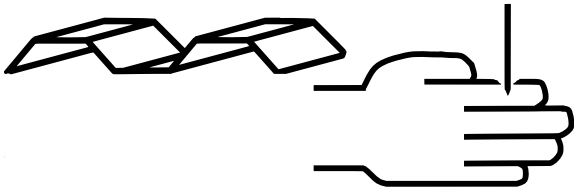

Care must be taken when handling various pieces of your building since many contain sharp edges. Please wear work gloves, eye protection and long sleeves when assembling or performing any maintenance on your building.

## always practice proper tool safety

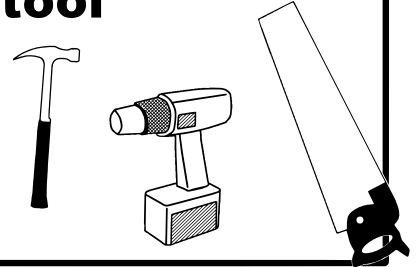

Practice caution with the tools being used in the assembly of this building. Be especially familiar with the operation of all power tools.

## no children or pets at worksite



Keep children and pets away from the worksite during construction and until the building is completely assembled. This will help avoid distractions and any accidents which may occur.

## don't focus weight on roof

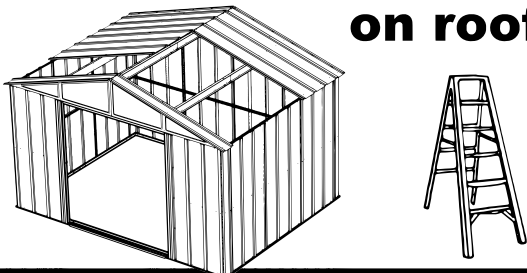

NEVER concentrate your weight on the roof of the building. When using a step ladder make sure that it is fully open and on even ground before climbing on it.



Do NOT attempt to assemble your building on a windy day. The large panels can catch the wind like a "sail", causing them to be whipped around making construction difficult and unsafe.

Do NOT attempt to assemble your building before double checking that you have all the parts indicated in the parts lists, as well as all hardware (page 6-11). Any building left partially assembled may be seriously damaged by even light winds.

## IMPORTANT NOTE ON ANCHORING

- Your building MUST be anchored to prevent wind damage. An anchoring kit is not supplied with your building and you have many options when it comes to anchoring. See anchoring page for more info.
- If you need to take a break from assembly, place sandbags or other weights on the floor frame to temporarily anchor it.

# ASSEMBLY TIPS & TOOLS

**Watch the Weather Closely:** Be sure the day you choose to install your building is dry and calm. Do **NOT** attempt to assemble your building on a windy day. Be careful on wet or muddy ground.

**Use Teamwork:** Two or more people are required to assemble your building. One person can hold the parts or panels in place while the other person fastens them together and handles the tools. This makes the process of assembling your building faster and safer.

**Tools and Materials:** Here is a list of some basic tools and materials you will need to assemble your building. Decide which method of anchoring and the type of base you will use to make a complete list of the materials you will need.

## WHAT YOU NEED

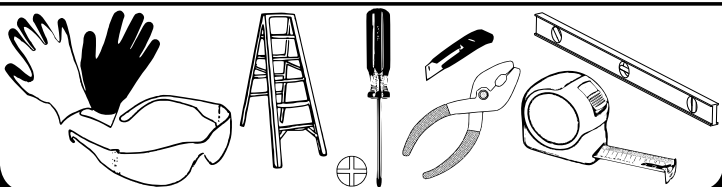

- Work Gloves
- Safety Glasses
- Step Ladder
- No. 2 Phillips Screwdriver (Magnetic Tip Preferred)
- Utility Knife or Scissors
- Pliers
- Carpenter's Level
- Tape Measure

## RECOMMENDED TIME SAVERS

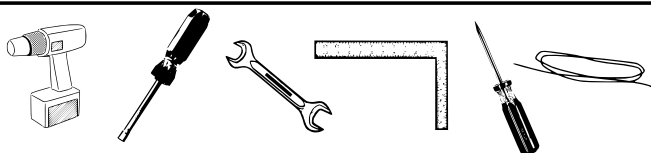

- Power Drill (Cordless, Variable Speed)
- Nut Driver or Wrench
- Square
- String (for squaring the frame)
- Awl (to align holes)

## BASE PREPARATION TOOLS

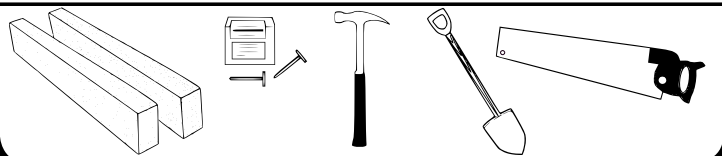

- Lumber and/or Concrete
- Hammer and Nails
- Spade or Shovel
- Hand Saw or Power Saw

**How to Select and Prepare Your Building Site:** Before you start to assemble your building, you will want to decide on a good location. The best location is a level area with good drainage.

- Allow enough working space so it is not difficult to move parts into position for assembly. Be sure there will be enough space at the entrance for the doors to completely open. Also, there needs to be enough space outside the building to be able to fasten the panel screws from the outside.
- Before assembling any parts, your base should be constructed and an anchoring system should be ready to use.

# BEFORE YOU BEGIN...

*Your Commander™ / Mountaineer™ Shed has a Modular Design.*

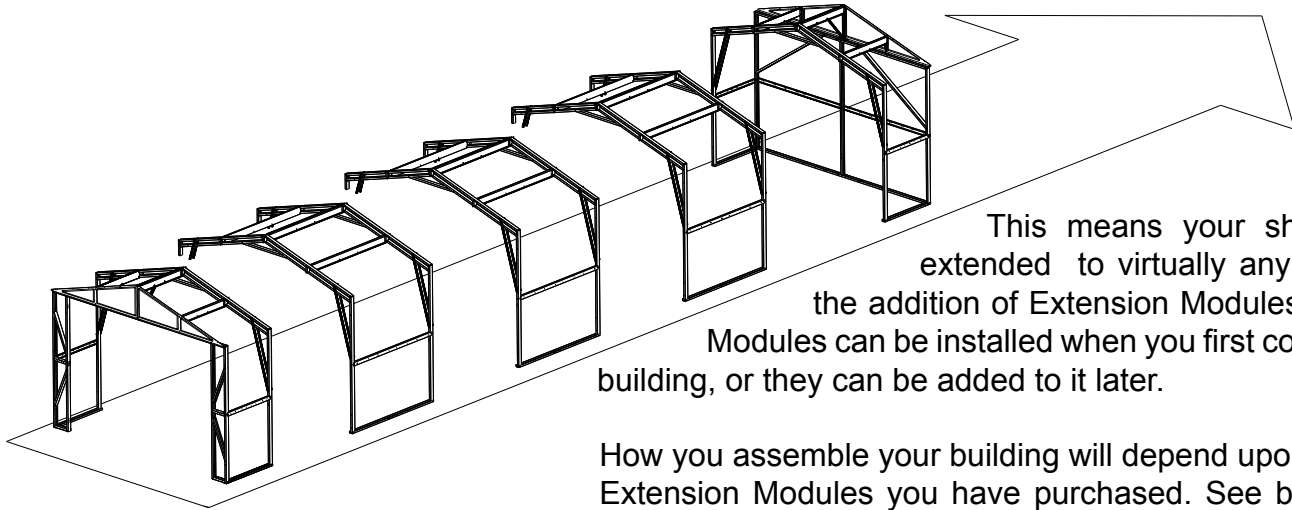

This means your shed can be extended to virtually any length with the addition of Extension Modules. Extension Modules can be installed when you first construct your building, or they can be added to it later.

How you assemble your building will depend upon how many Extension Modules you have purchased. See below to see how many Modules are included in your building.

## *How your building was shipped.*

Now that you have received your building you need to take inventory of what you have to ensure nothing is missing.

Depending on the size building you purchased, your building arrived in two or more cartons. Locate the carton label; you should have one carton labeled **C1GA-A** and one labeled **C2GA-A**. Also, if you purchased a building 15' (4,6 m) in length or longer, you should have at least one carton labeled **GA5M-A**.

**C1GA-A** - This carton contains the painted parts needed to erect a 10' (3,1 m) building. You should have one **C1GA-A** carton.

**C2GA-A** - This carton contains the un-painted parts needed to erect a 10' (3,1 m) building. You should have one **C2GA-A** carton.

**GA5M-A** - This carton contains the Extension Module. Review the chart to the right to determine how many **GA5M-A** cartons you should have received.

**Please note:** Most illustrations in this assembly manual depict a 10'x10' (3,0 m x 3,1 m) building. A 10'x10' (3,0 m x 3,1 m) building contains a front and rear wall section and one truss section (see page 9). Each additional Extension Module simply adds one more truss section to the building (see page 11). Every truss section is identical to every other truss section and the instructions clearly indicate how to assemble any length building. Read all instructions carefully.

Nominal Size	Extension Modules
10'x10'	0
10'x15'	1
10'x20'	2
10'x25'	3
10'x30'	4

Nominal Size	Extension Modules
3,0 m x 3,1 m	0
3,0 m x 4,6 m	1
3,0 m x 6,1 m	2
3,0 m x 7,5 m	3
3,0 m x 9,0 m	4

# CONSTRUCTING A BASE...

## Before you assemble your building, you must construct a base.

The length of your base, shown as "L" in the diagrams below, will depend on the length of your building. See below.

Nominal Size		# of Modules	Length "L"	
10'x10'	3,0 m x 3,1 m	0	127 1/2"	323,9 cm
10'x15'	3,0 m x 4,6 m	1	185"	469,9 cm
10'x20'	3,0 m x 6,1 m	2	242 1/2"	616,0 cm
10'x25'	3,0 m x 7,5 m	3	300"	762,0 cm
10'x30'	3,0 m x 9,0 m	4	357 1/2"	908,1 cm

For each additional module beyond the lengths listed, increase the length of your base by 57 1/2" (146,1 cm).

**IMPORTANT:** When deciding on a base for your building you must take into consideration use and permit requirements. A concrete base is best for most purposes, but a wood platform may be suitable for light use. Before beginning construction, check local building codes regarding footings, location and other requirements.

## OPTION 1: Concrete Slab

The slab should be at least 4" (10,2 cm) thick. It must be level and flat to provide good support for the frame.

The following are the recommended materials for your base.

- 1 x 4's (19 mm x 89 mm) (will be removed once the concrete cures)
- Concrete • Sheet of 6 mil plastic
- We recommend for a proper strength concrete to use a mix of:  
1 part cement • 3 parts pea sized gravel • 2 1/2 parts clean sand

### Prepare the Site/Construct a Base

1. Dig a square, 6" (15,2 cm) deep into the ground (remove grass).
2. Fill up to 4" (10,2 cm) in the square with gravel and tamp firm.
3. Cover gravel with a sheet of 6 mil plastic.
4. Construct a wood frame using four planks of 1x4 (19 mm x 89 mm) lumber.
5. Pour in concrete to fill in the hole and the frame giving a total of 4" (10,2 cm) thick concrete. Be sure surface is level.

Allow 3 - 5 hours for construction and a week for curing time.

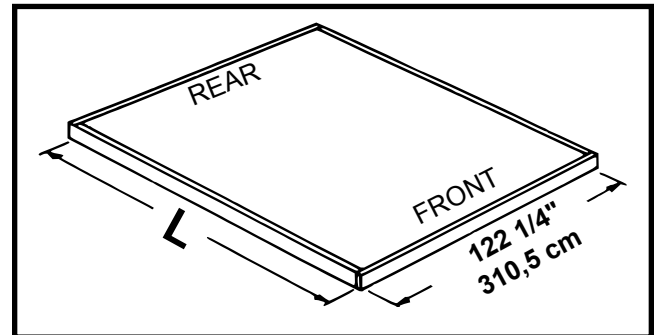

**Note:** Finished Slab dimensions, with lumber removed. Platform/Slab will extend 2" (5 cm) beyond floor frame on all four sides. Seal this 2" (5 cm) of wood with a roofing cement (not included), or bevel concrete when pouring for good water drainage.

## OPTION 2: Wood Platform

These are the recommended materials for your base:

- 2 x 4's (38 mm x 89 mm) Pressure Treated Lumber • 5/8" (15,5 mm) 4 x 8 (1220 mm x 2440 mm) Plywood-exterior grade
- 10 & 4 penny Galvanized Nails • Concrete Blocks (optional)

**NOTE:** Pressure Treated Lumber must not be used where it will make contact with your storage building. The properties of Pressure Treated Lumber will cause accelerated corrosion. **If Pressure Treated Lumber comes in contact with your storage building your warranty will be voided.**

The platform should be level and flat (free of bumps, ridges etc.) to provide good support for the building. The necessary materials may be obtained from your local lumber yard.

To construct the base follow instructions and diagram.

- Construct frame (using 10 penny galvanized nails)
- Measure 16"/24" (40,6 cm/61,0 cm) sections to construct inside frame (see diagram)
- Secure plywood to frame (using 4 penny galvanized nails)

Allow 6 - 7 hours for construction.

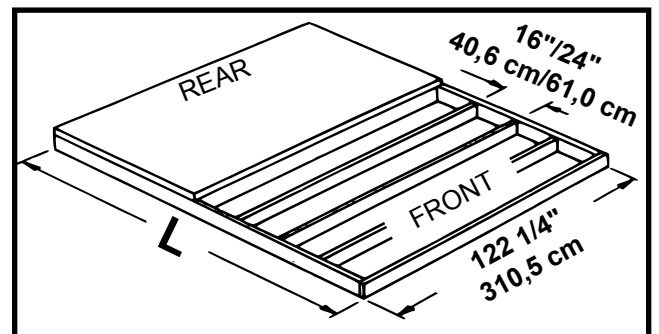

# HARDWARE - C1GA-A

## C1GA-A Hardware

Key No.	Part No.	Part Description	Qty.	✓ List
1	65103	Hex Nut (#8-32)	220	
2	65106	Square Nut (#10-32)	36	
3	65923	Small Bolt (#8-32 x 3/8) (10 mm)	184	
4	65943	Large Bolt (#10-32 x 7/16) (11 mm)	30	
5	66625	Long Bolt (#10-32 x 3/4) (19 mm)	2	
6	66783	Flat Head Screw (#8-32 x 1/2) (13 mm)	36	
7	65004	Small Screw (#8AB x 5/16) (8 mm)	336	
8	66611	Large Screw (#10AB x 1/2) (13 mm)	317	
9	66646	Washer Sheet	11	
10	66609	Hinge	6	
11	66778	Lock Eyelet	1	
12	66781	Spring Latch	1	
13	6228	Track Support	4	
14	67545B	Weather Stripping	1	
15	66183L/R	Roof Trim Cap	4	
16	67468	Peak Cap (Arrow Logo)	2	

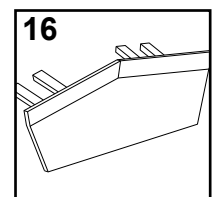
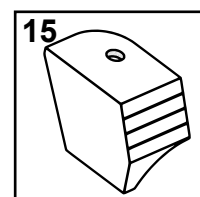
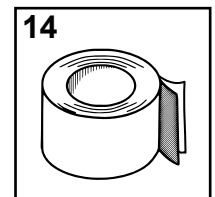
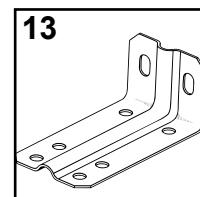
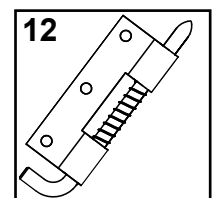
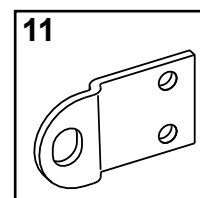
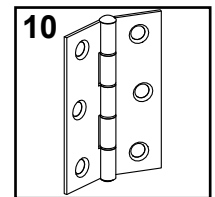
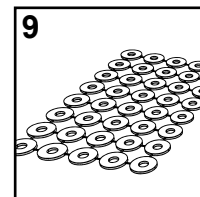
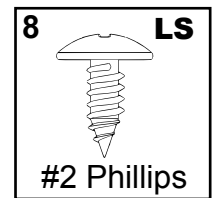
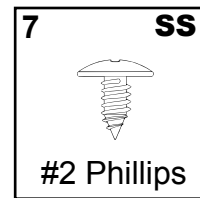
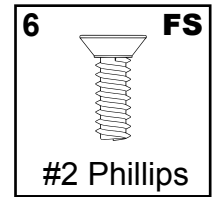
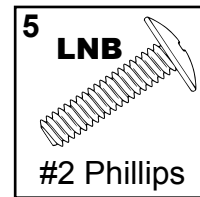
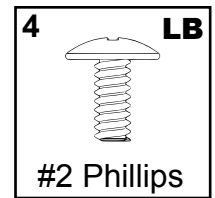
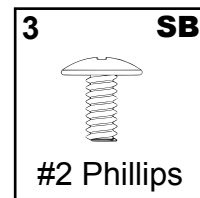
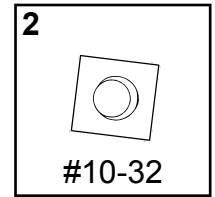
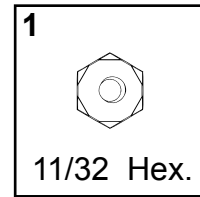

**Confirm that all hardware and parts are present before attempting to assemble your building.**

For missing or damaged parts, contact Customer Service. Do not return to store.

## Part Numbers

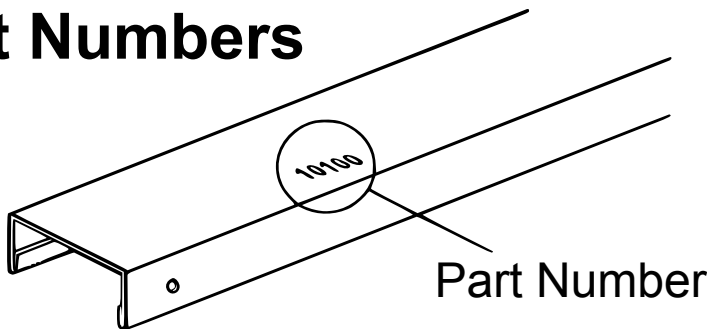

1. Each part has an identifying part number on it.
2. Part Numbers are referenced in each step.
3. Unpainted parts have a stamped in number and painted parts have a number that is inked on.

**Remove inked on numbers with soap and water after assembly.**

# HARDWARE - C2GA-A / GA5M-A

## C2GA-A Hardware \*Packed loose in carton

Key No.	Part No.	Part Description	Qty.	✓ List
1	10651	Latch Plate *	3	
2	7003	Shear Plate LT *	8	
3	7004	Shear Plate RT *	8	
4	66779	Slide Bolt *	1	
5	66780	Cane Bolt *	2	
6	66782	Door Handle *	2	

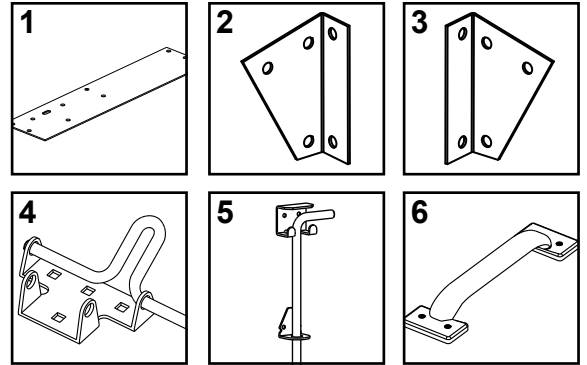

## GA5M-A Hardware

Key No.	Part No.	Part Description	Qty.	✓ List
2	7003	Shear Plate LT *	4	
3	7004	Shear Plate RT *	4	
7	65103	Hex Nut (#8-32)	56	
8	65106	Square Nut (#10-32)	8	
9	65923	Small Bolt (#8-32 x 3/8) (10 mm)	56	
10	65943	Large Bolt (#10-32 x 7/16) (11 mm)	8	
11	65004	Small Screw (#8AB x 5/16) (8 mm)	174	
12	66611	Large Screw (#10AB x 1/2) (13 mm)	82	
13	66646	Washer Sheet	6	
14	67293B	Weather Stripping	1	

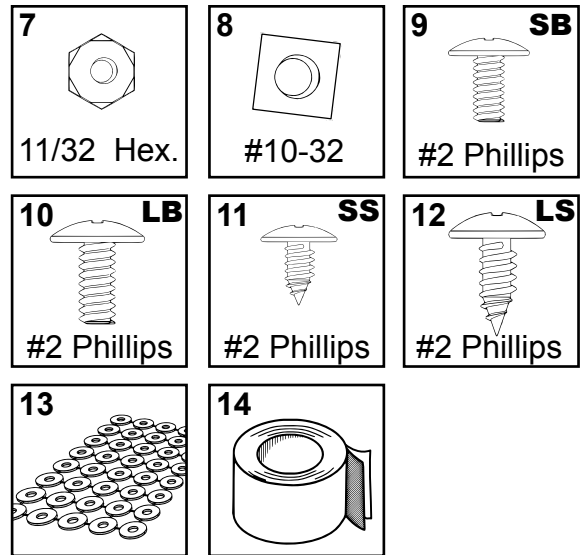

## Some Tips for Assembly:

At the top of each page you will see one or more **Part Cues** like the one to the right. These **Part Cues** are designed to help you quickly identify the parts needed for each step.

Various fasteners are used throughout the construction of your building. In each step you will see the abbreviations listed below used in the illustrations to help you identify which fastener to use.

- SB** - Small Bolt
- SS** - Small Screw
- LB** - Large Bolt
- LS** - Large Screw
- FS** - Flat Head Screw
- LNB** - Long Bolt

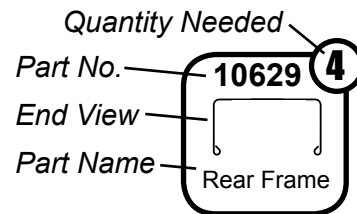
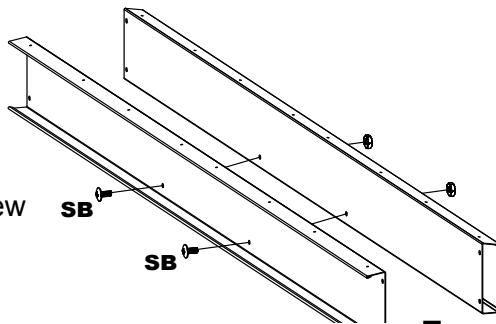

The fasteners used in each step are shown actual size at the top of each page. If you are unsure which fastener to use, hold it up to the picture and use the one that matches.

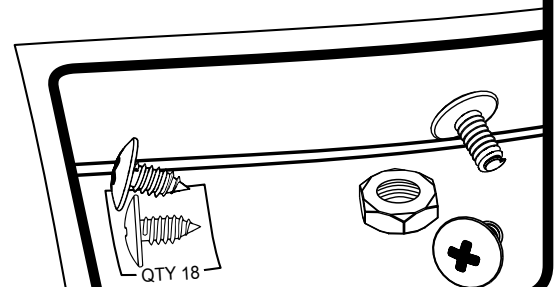

# PARTS LIST - MAIN BUILDING

Key No.	Carton No.	Part No.	Part Description	Qty.	✓ List
1	C1GA-A	7743	Roof Panel	8	
2	C1GA-A	7822	Wall Panel	12	
3	C1GA-A	8576	Right Gable	2	
4	C1GA-A	8577	Left Gable	2	
5	C1GA-A	8578	Right Roof End Panel	2	
6	C1GA-A	8579	Left Roof End Panel	2	
7	C1GA-A	10618	Front Wall Panel	2	
8	C1GA-A	10619	Corner Panel	4	
9	C1GA-A	10620	Right Roof Trim	2	
10	C1GA-A	10621	Front and Rear Ridge Cap	2	
11	C1GA-A	10622	Right Door Jamb	1	
12	C1GA-A	80017	Left Roof Trim	2	
13	C1GA-A	80037	Left Door Jamb	1	
14	C2GA-A	6635	Roof Beam Bracket	4	
15	C2GA-A	9009	Gable Brace	2	
16	C2GA-A	9204	Roof Beam Brace	2	
17	C2GA-A	10625	Side Wall Angle	4	
18	C2GA-A	10627	Front Wall Channel	6	
19	C2GA-A	10628	Front Wall Diagonal	4	
20	C2GA-A	10629	Rear Frame	4	
21	C2GA-A	10630	Rear Wall Channel	2	
22	C2GA-A	10631	Rear Wall Diagonal	2	
23	C2GA-A	10632	Side Frame	4	
24	C2GA-A	10886	Front and Rear Side Wall Channel	4	
25	C2GA-A	10887	Mid Side Wall Channel	2	

Key No.	Carton No.	Part No.	Part Description	Qty.	✓ List
26	C2GA-A	10878	Long Fascia	1	
27	C2GA-A	10879	Short Fascia	1	
28	C2GA-A	10640	Wall Post	5	
29	C2GA-A	10881	Truss Post	4	
30	C2GA-A	10882	Truss Post Insert	4	
31	C2GA-A	10883	Upper Chord Truss	4	
32	C2GA-A	10884	Lower Chord Truss	4	
33	C2GA-A	10885	Truss Splice	2	
34	C2GA-A	10646	Knee Brace	8	
35	C2GA-A	10649	Front and Rear Roof Beam	8	
36	C2GA-A	10650	Mid Roof Beam	4	
37	C2GA-A	10652	Wall Post (Hinge)	2	
38	C2GA-A	10880	Front Frame	2	

Green Plastic Edge Trim is also included in carton C1GA-A and must be used when assembling your building.

**Length: 65 3/4" (167,0 cm)**

**QTY: 4**

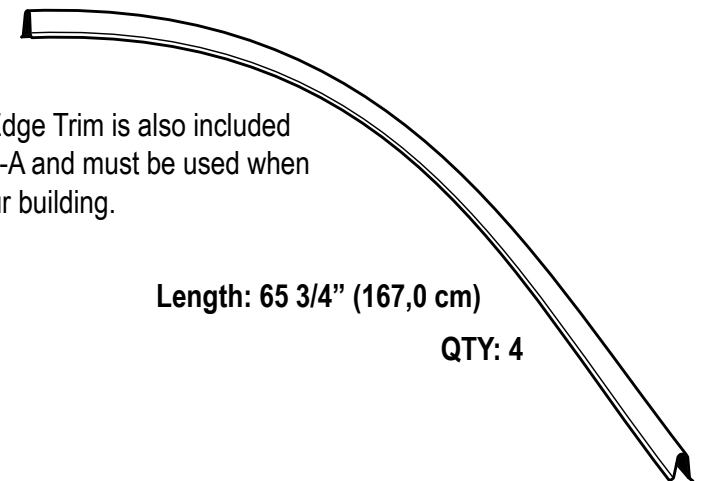



**NOTE**

Part No. 30 (Truss Post Insert) fits inside Part No. 29 (Truss Post) and is not shown below.

**Part 10627 Front Wall Channel (No. 18) may be joined in pairs.**

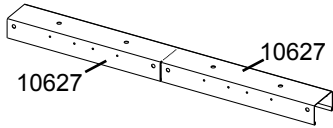

**Bend to separate.**

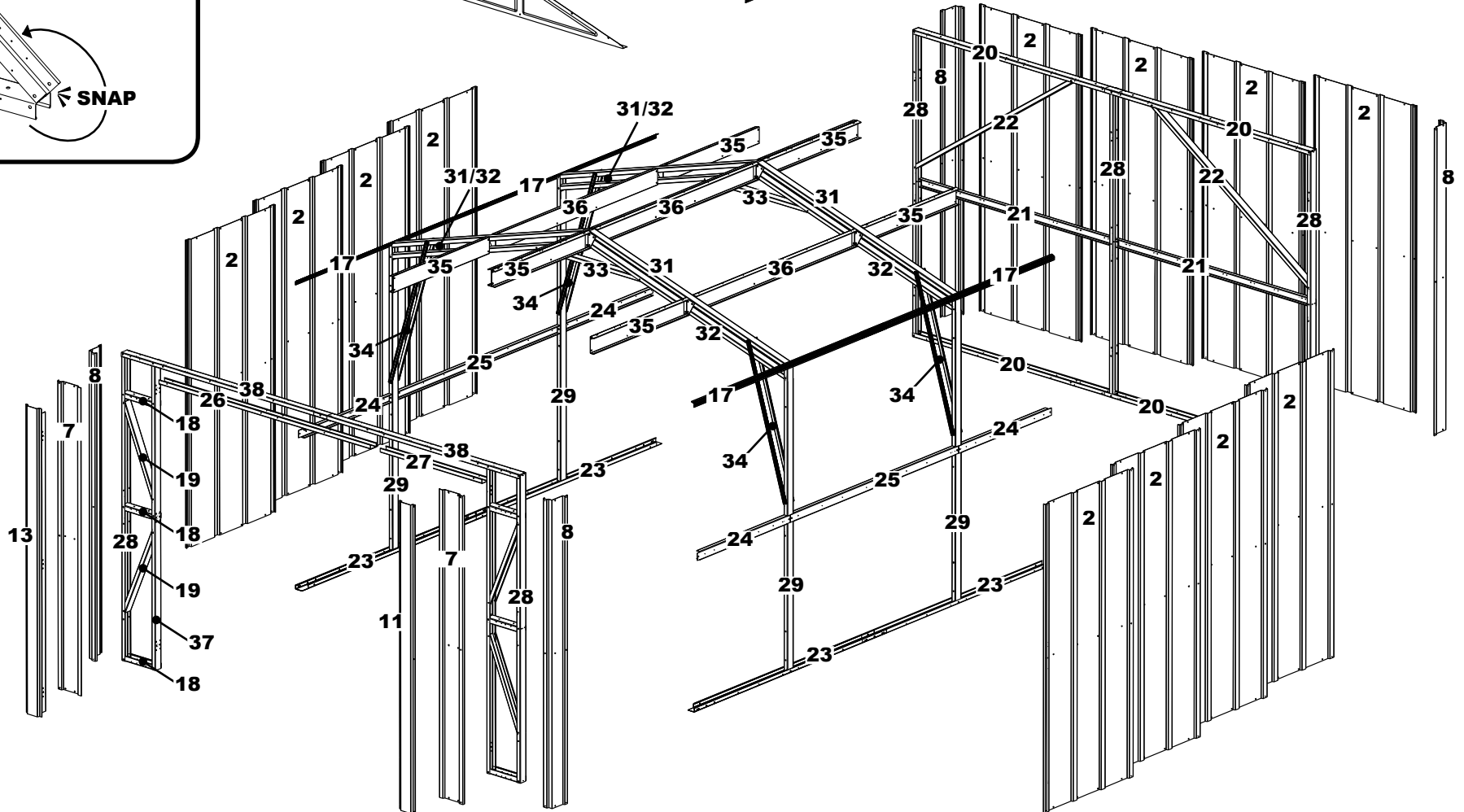
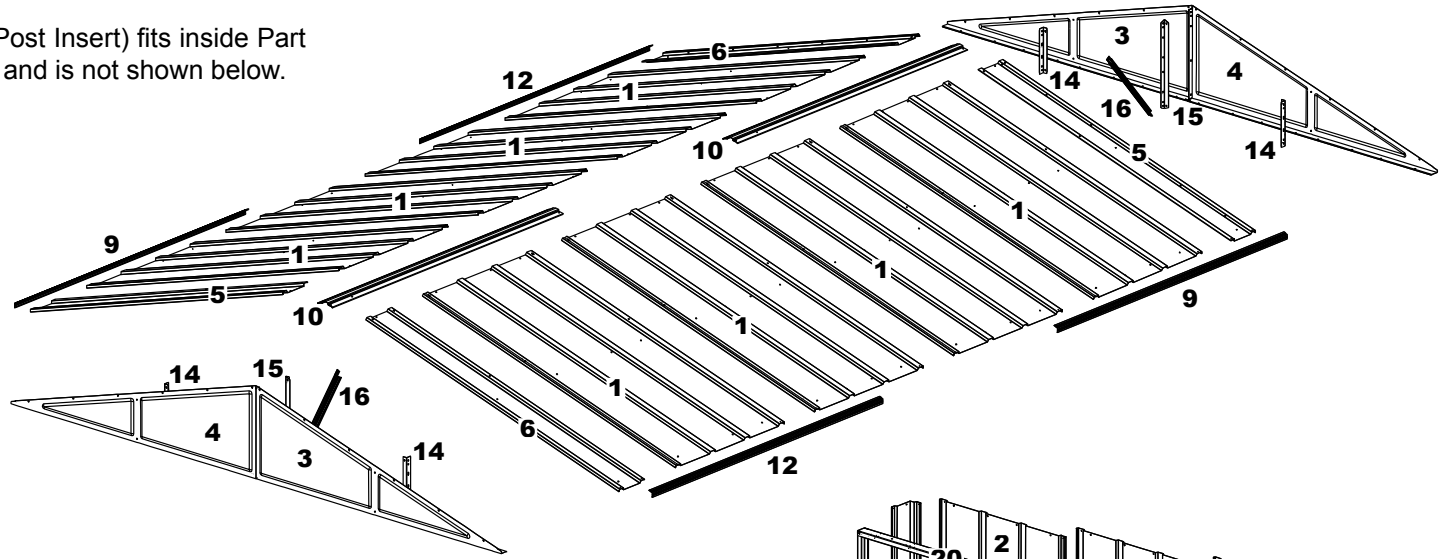
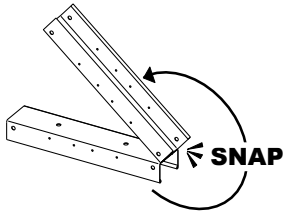

# PARTS LIST - DOORS & MODULE

## DOORS

Key No.	Carton No.	Part No.	Part Description	Qty.	✓ List
1	C1GA-A	10623	Door Panel (Hinge)	2	
2	C1GA-A	10624	Right Door Panel	1	
3	C1GA-A	80051	Left Door Panel	1	
4	C1GA-A	10635	Horizontal Door Brace	4	
5	C1GA-A	10678	Vertical Door Brace (Latch)	2	
6	C1GA-A	10637	Vertical Door Brace (Hinge)	2	
7	C1GA-A	10647	Top Door Trim	2	
8	C1GA-A	10648	Door Astragal	2	
9	C2GA-A	10626	Door Diagonal Brace	8	
10	C2GA-A	10636	Vertical Door Brace	4	
11	C2GA-A	10675	Cane Bolt Bracket	2	

## EXTENSION MODULE

Key No.	Carton No.	Part No.	Part Description	Qty.	✓ List
12	GA5M-A	7822	Wall Panel	4	
13	GA5M-A	7743	Roof Panel	4	
14	GA5M-A	6015	Roof Trim	2	
15	GA5M-A	10680	Mid Ridge Cap	1	
16	GA5M-A	10625	Side Wall Angle	2	
17	GA5M-A	10632	Side Frame	2	
18	GA5M-A	10887	Mid Side Wall Channel	2	
19	GA5M-A	10650	Mid Roof Beam	4	
20	GA5M-A	10881	Truss Post	2	
21	GA5M-A	10882	Truss Post Insert	2	
22	GA5M-A	10883	Upper Chord Truss	2	
23	GA5M-A	10884	Lower Chord Truss	2	
24	GA5M-A	10885	Truss Splice	1	
25	GA5M-A	10646	Knee Brace	4	

### Left Door

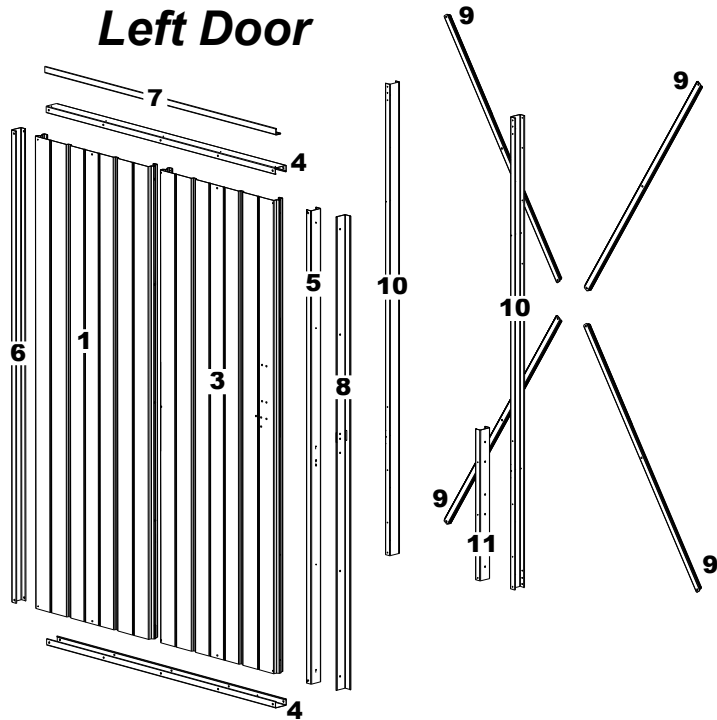

### Right Door

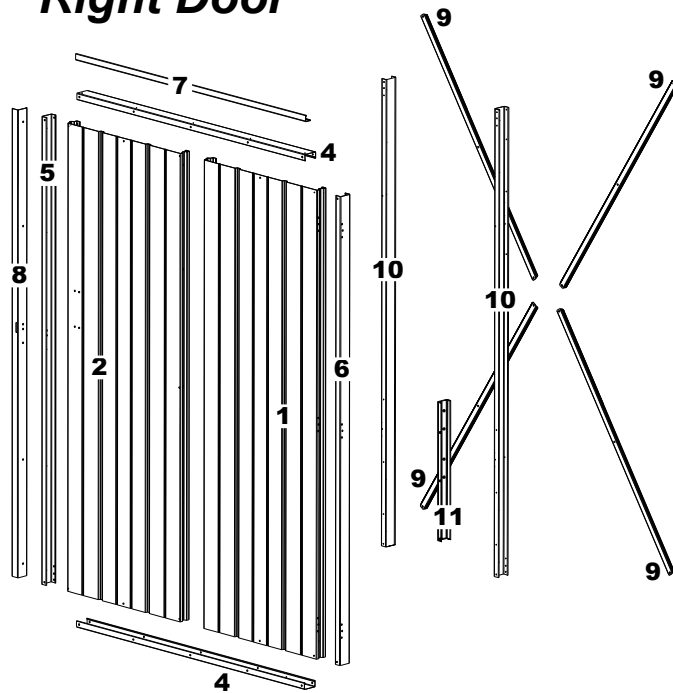

### Extension Module

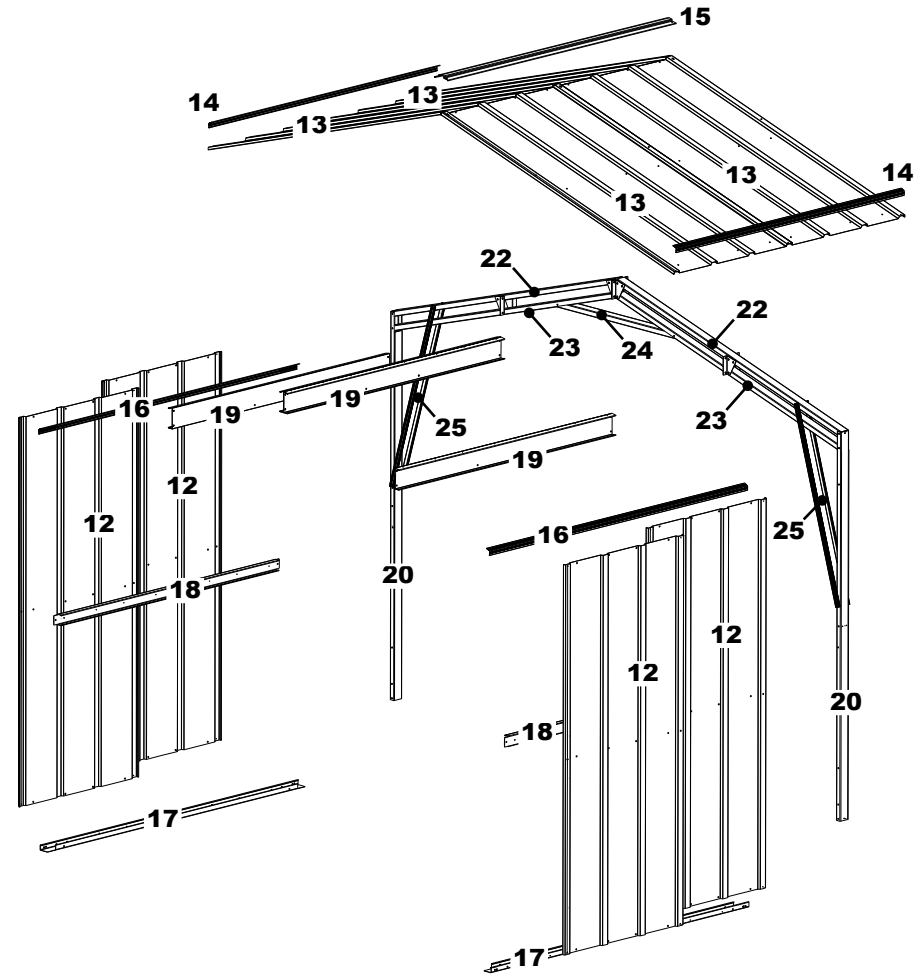

**NOTE** Part No. 21 (Truss Post Insert) fits inside Part No. 20 (Truss Post) and is not shown above.

# Step 1: Trusses

You will need for this page:

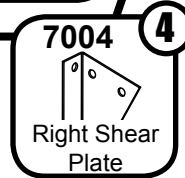
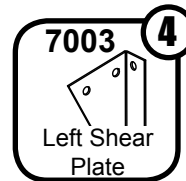
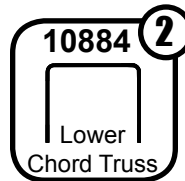
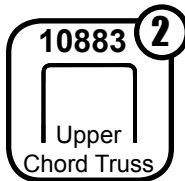
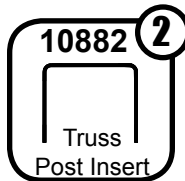
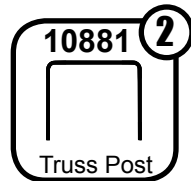
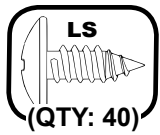

**NOTE** Washers are to be used on painted parts only. Washers are not necessary on unpainted parts and there are not enough to use on every Screw and Bolt.

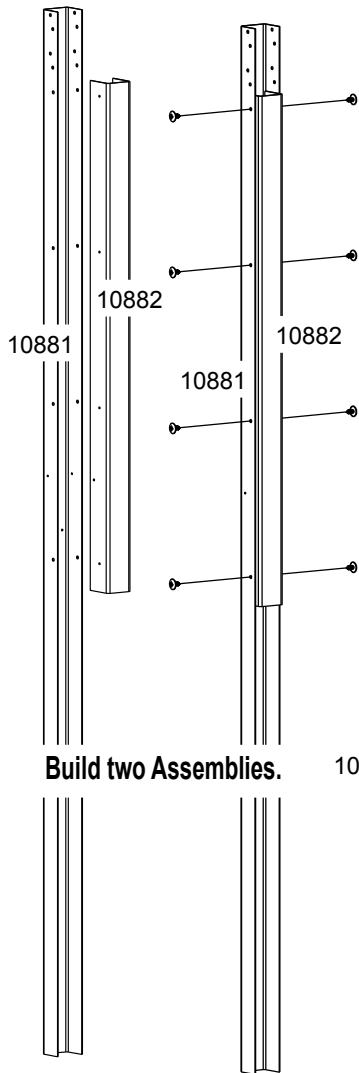

Build two Assemblies.

**1** Align the **Truss Post** and **Truss Post Insert** and join as shown. Insert **Large Screws** along both sides of the **Truss Post** where holes align.

**2** Repeat instruction 1 to build a second **Truss Post Assembly**. Set aside for use on next page.

**3** With the **Upper and Lower Chord Trusses** positioned as shown below, attach **Shear Plates** where indicated below. Attach **Shear Plates** using **Large Screws** to **Upper Chord** first, then to the **Lower Chord**.

**4** Repeat instruction 3 to build a second **Chord Truss Assembly**. Set aside for use on next page.

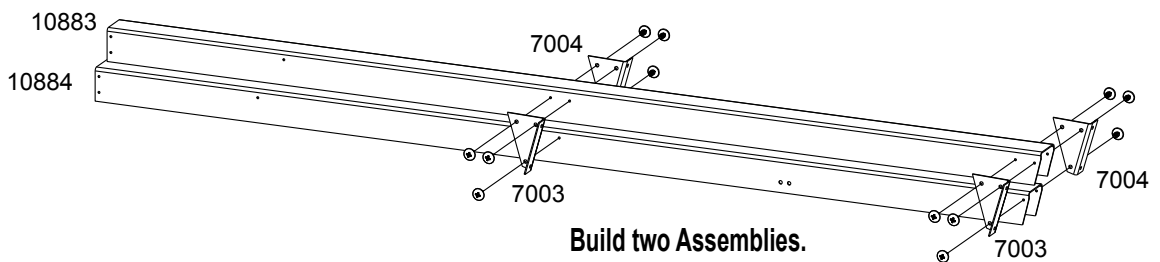

Build two Assemblies.

Holes must align in this direction.

CORRECT

INCORRECT

Not this direction

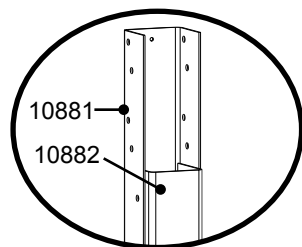

Truss Post Insert fits **INSIDE** Truss Post as shown.

# Step 1: Continued

You will need for this page:

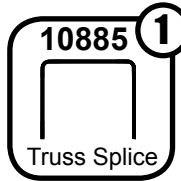
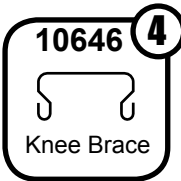
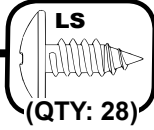
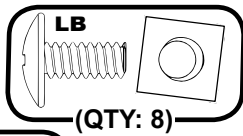
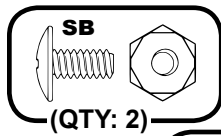

Assemblies from previous page:

- Truss Post Assembly (2)
- Chord Truss Assembly (2)

**5** Next, insert the **Upper/Lower Chord Truss Assembly** into the **Truss Post Assembly** as shown. Secure with **Large Screws**. Do not tighten at this time. Repeat for other side.

**6** Attach **Truss Splice** to **Truss** using **Large Bolts** and **Nuts** as shown below, but do not tighten at this time. Temporarily secure the peak of the **Truss** using two (2) **Small Bolts** and **Nuts** as shown.

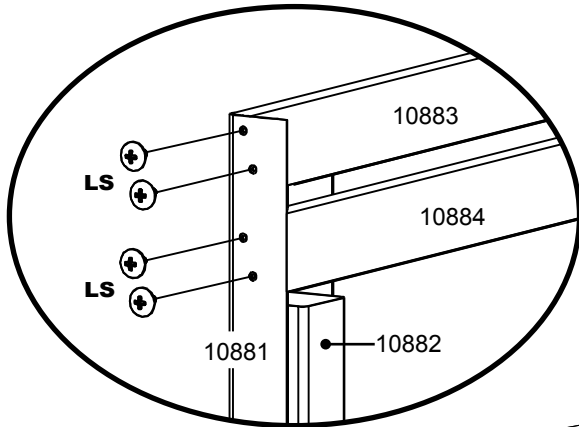

**7** Attach **Knee Braces** to **Truss** using **Large Screws** as shown. Do not tighten at this time. With the **Truss** assembled, check that the width of the **Truss** is 118 1/4" (300,4 cm) across the top and bottom of the **Truss**. If so, tighten all fasteners. Repeat steps to build additional **Trusses**.

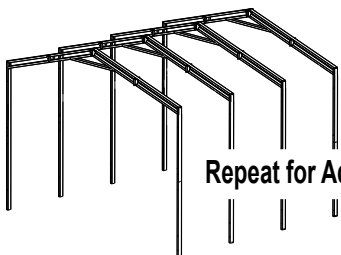
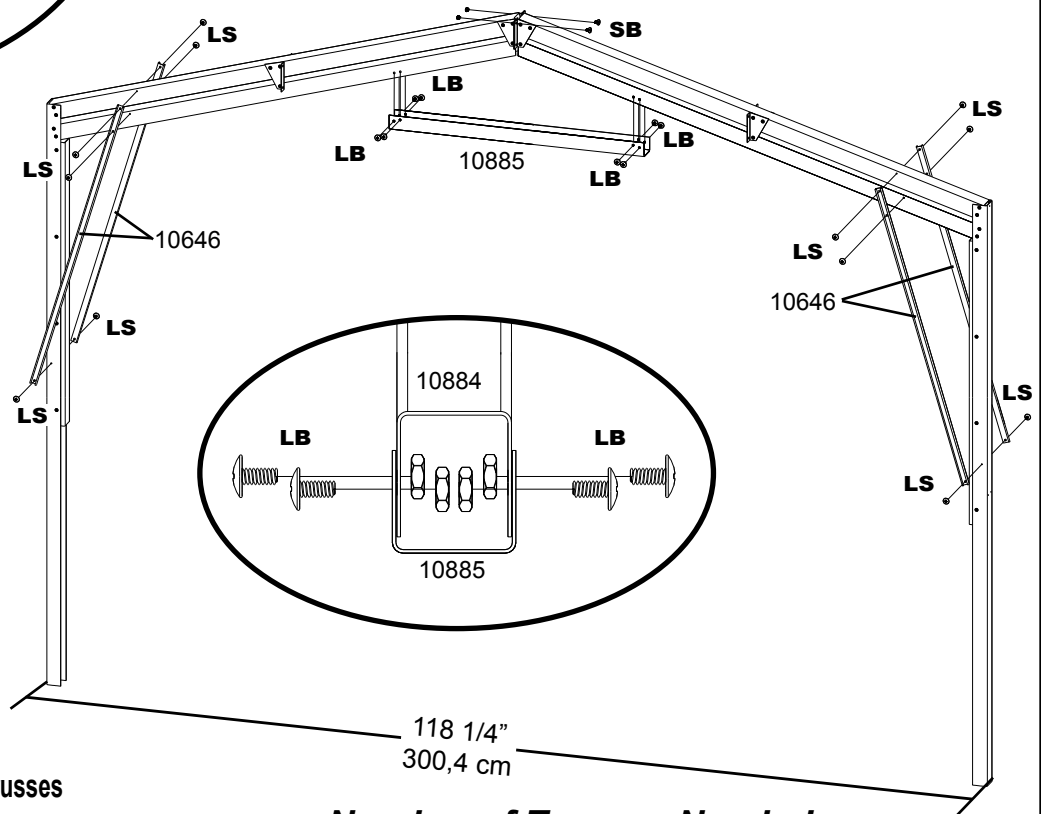

Repeat for Additional Trusses

Number of Trusses Needed

Nominal Size		# of Modules	# of Trusses
10'x10'	3,0 m x 3,1 m	0	2
10'x15'	3,0 m x 4,6 m	1	3
10'x20'	3,0 m x 6,1 m	2	4
10'x25'	3,0 m x 7,5m	3	5
10'x30'	3,0 m x 9,0 m	4	6

**NOTE** The number of Trusses you will need to construct your building will depend on the size of your building. All buildings require at least two Trusses. See the chart to the right to determine the number of Trusses needed for your building.

# Step 2: Rear Wall

You will need for this page:

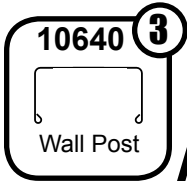
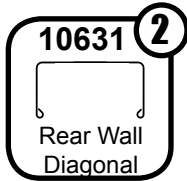
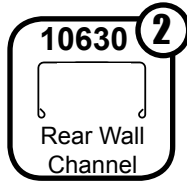
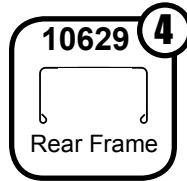
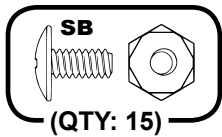
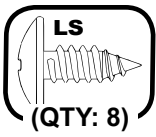

**NOTE** If you purchased a Door Kit, skip this page and move on to page 16.

**1** Lay out the parts and position them as shown. Overlap the **Rear Frames** by 4" (10,2 cm) and connect them to the **Wall Post** in the center of the **Rear Wall** using **Small Bolts** and **Nuts** as shown. Do not tighten at this time.

**2** Attach other two **Wall Posts** at the sides of the **Rear Wall** using **Small Bolts** and **Nuts** as shown. Attach both **Rear Wall Channels** using **Small Bolts** and **Nuts**. Slide the **Rear Wall Diagonals** into the **Frame** and secure with **Large Screws**.

overlap length:  
4" (10,2 cm)

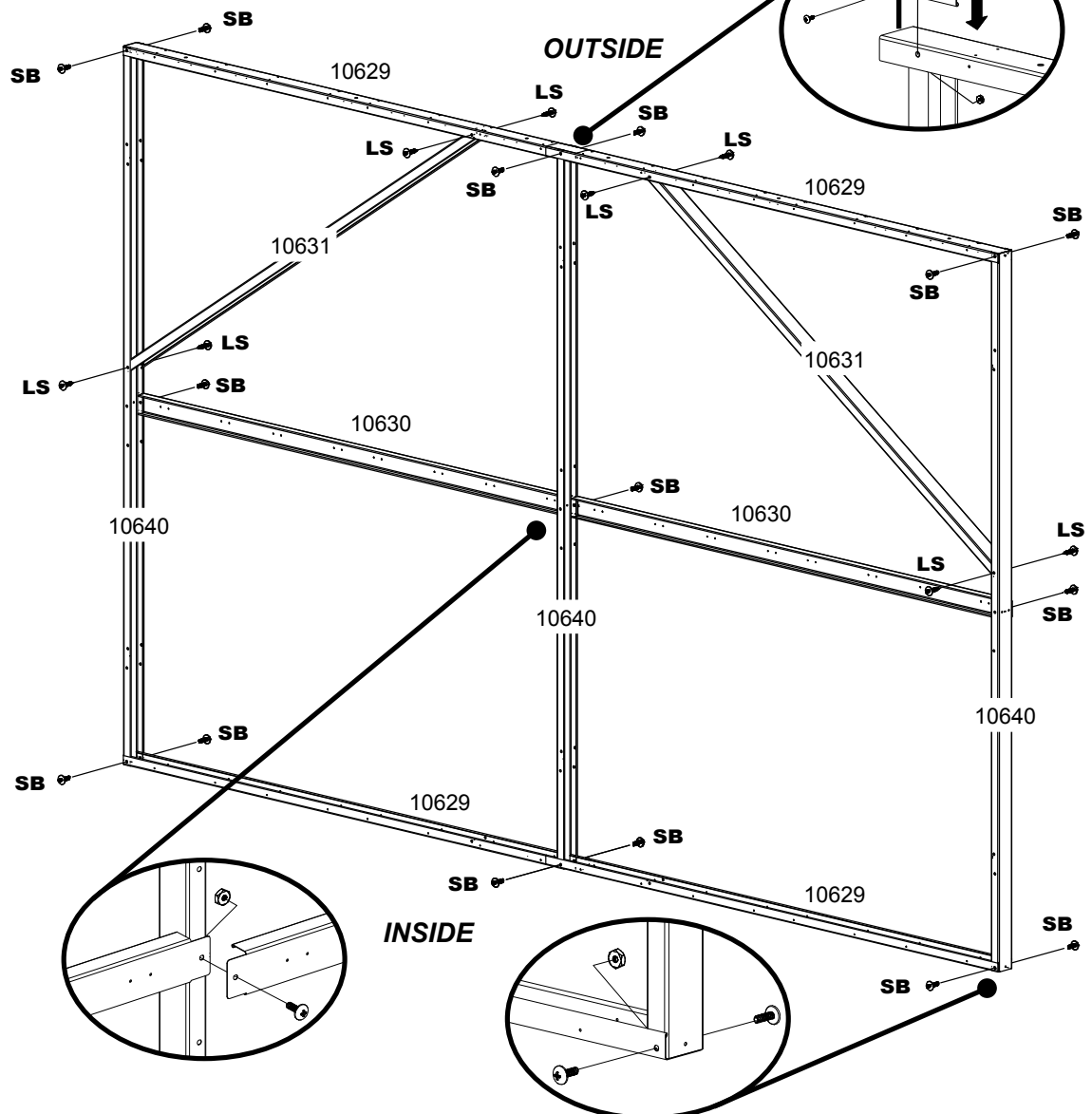

# Step 2: Continued

You will need for this page:

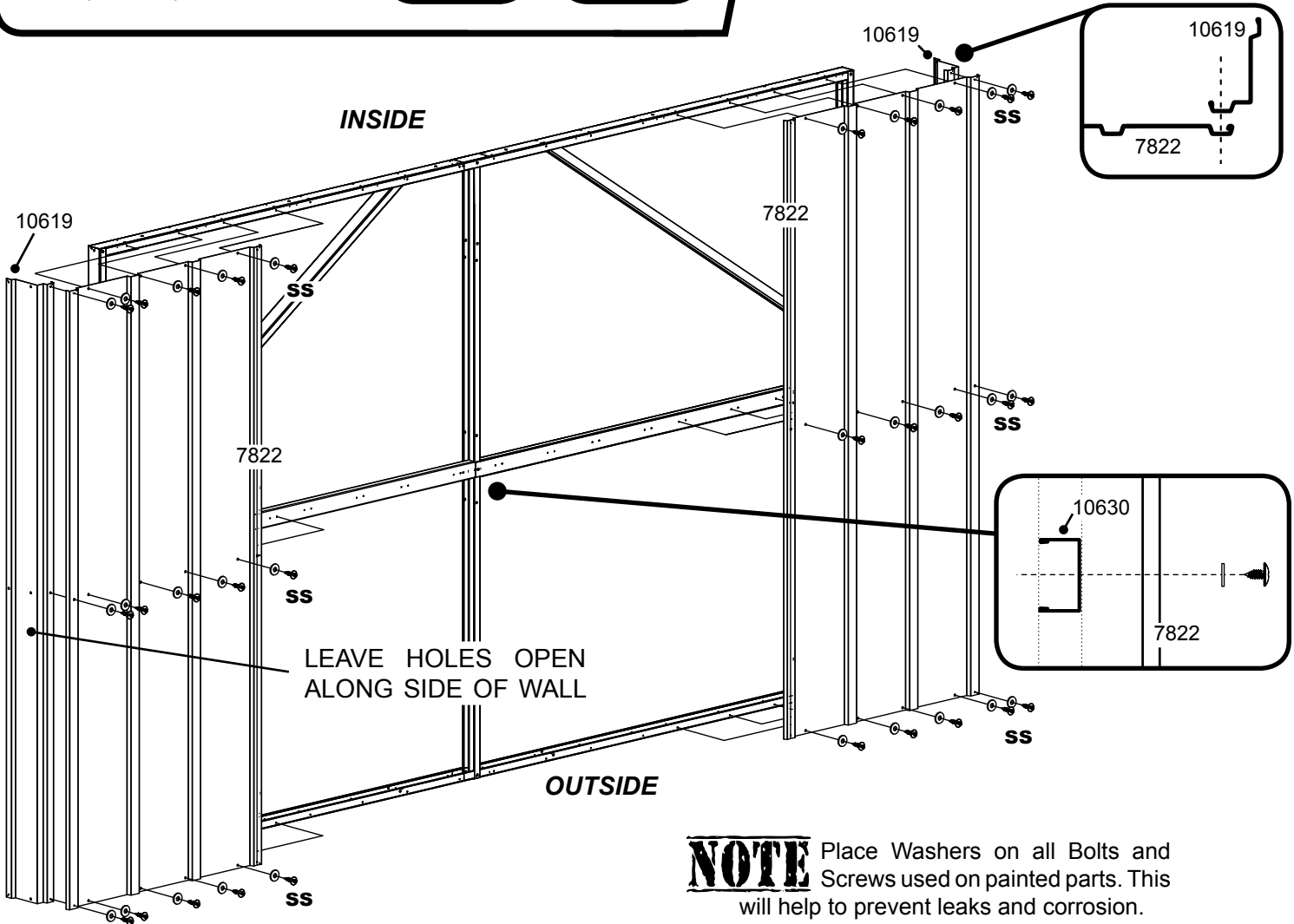
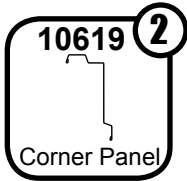
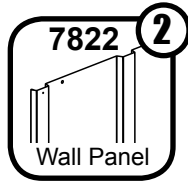
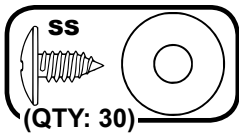

**3** Using **Small Screws**, attach a **Wall Panel** and **Corner Panel** to each corner of the **Rear Wall** as shown. The **Corner Panel** should only be secured to the **Wall Panel** where the **Panels** overlap. Do not secure the **Corner Panel** to the **Rear Wall** itself, this will be done in Step 5.

**4** Carefully set the **Rear Wall Assembly** aside for use in Step 5.

# Step 3: Front Wall

You will need for this page:

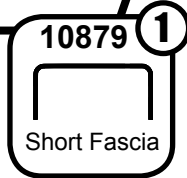
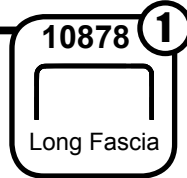
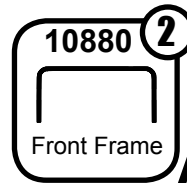
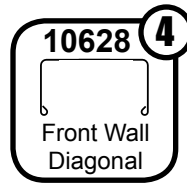
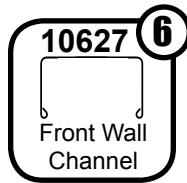
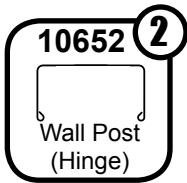
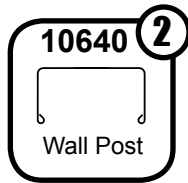
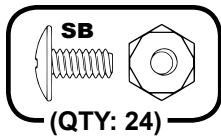
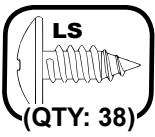

**NOTE** If you purchased a Door Kit, build two Front Walls.

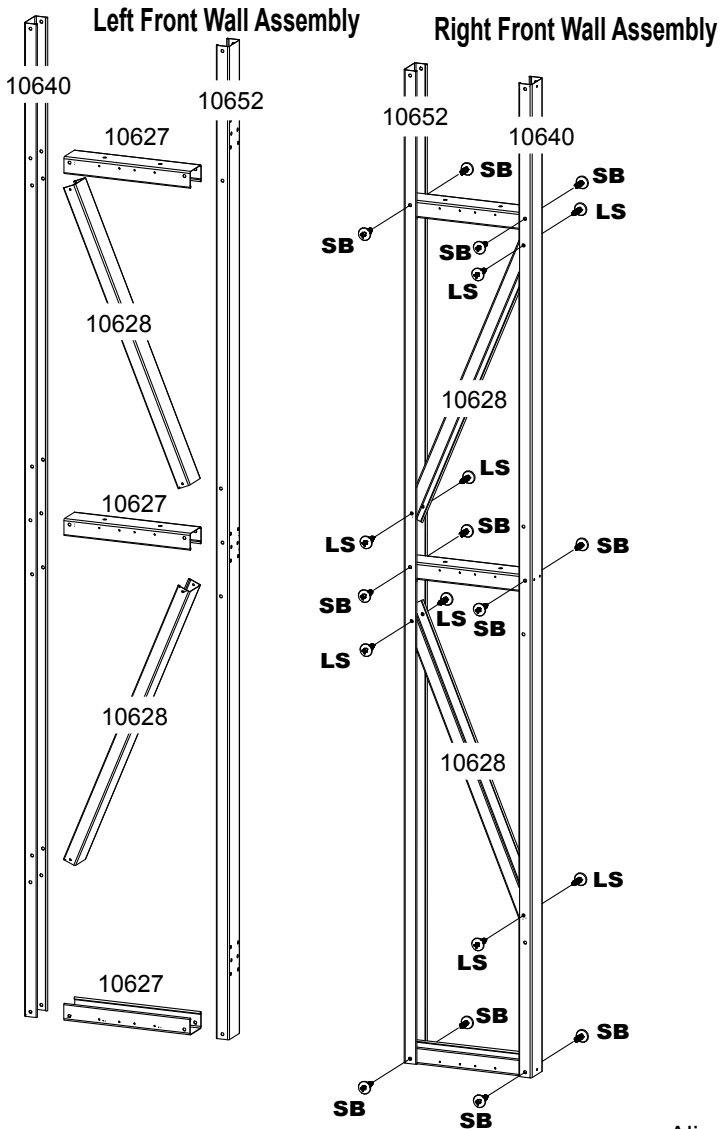

- 1** Lay out the parts and position them as shown. Double check that holes align as shown. If holes do not align, the **Wall Post (Hinge)** is most likely upside-down.
- 2** Insert the **Front Wall Channels** into the **Wall Post** and **Wall Post (Hinge)** as shown and secure with **Small Bolts and Nuts**.
- 3** Insert **Front Wall Diagonals** into the **Front Wall Assembly** as shown and secure with **Large Screws**.
- 4** Assemble two (2) **Front Frames** together with the **Long** and **Short Fascias** as shown below and secure using **Large Screws**.

**Part 10627 Front Wall Channel may be joined in pairs. Bend to separate.**

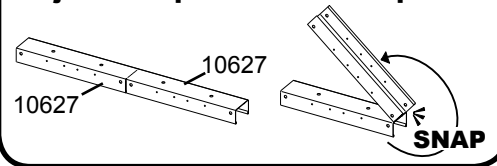

Overlap View

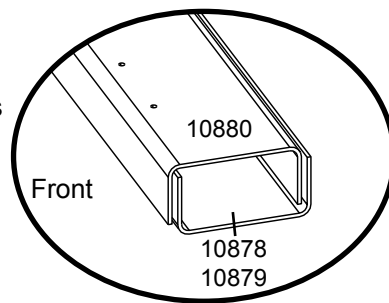

Front Frame faces outside of building.

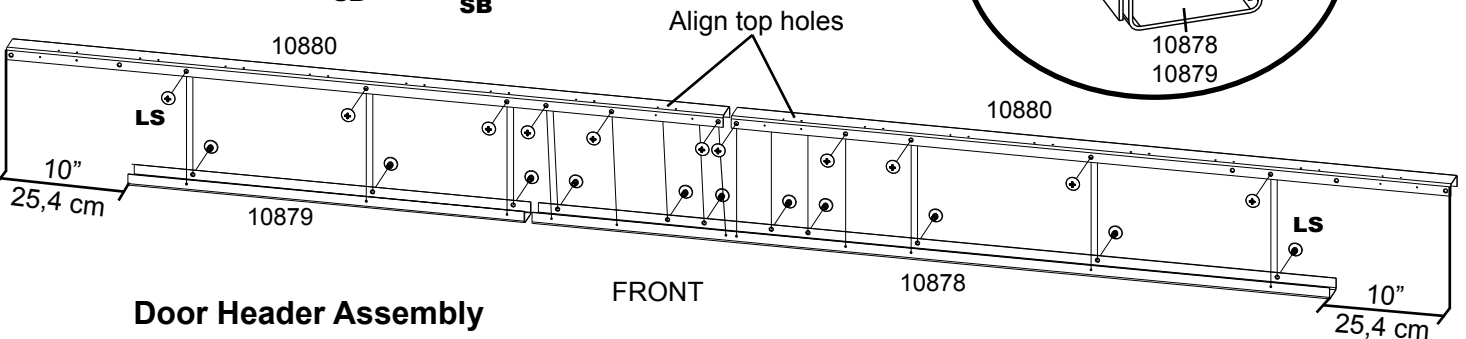

Door Header Assembly



# Step 3: Continued

You will need for this page:

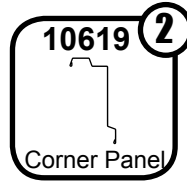
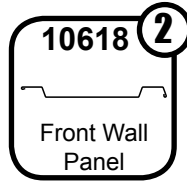
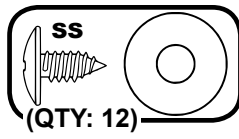
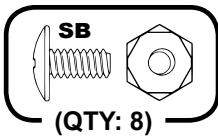

Assemblies from previous page:

- Left Front Wall Assembly
- Right Front Wall Assembly
- Door Header Assembly

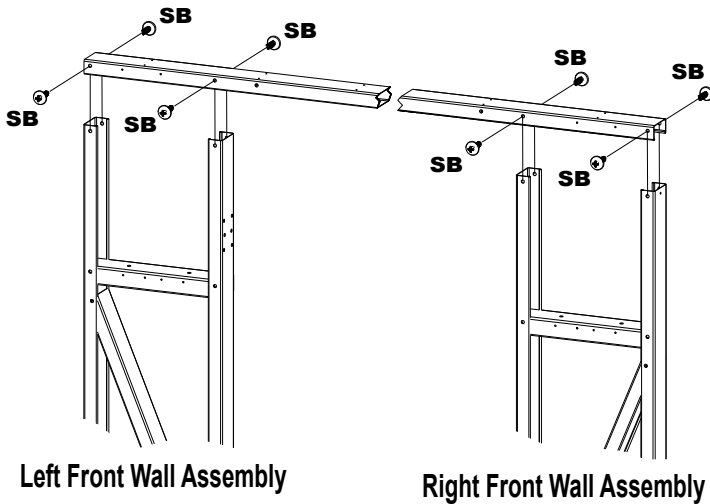

**5** Slide the **Door Header Assembly** down onto the **Front Wall Assemblies** as shown and secure with **Small Bolts** and **Nuts**. Once these pieces are joined, take care when moving them as the **Door Header** may bend.

**6** Using **Small Screws**, attach a **Front Wall Panel** and **Corner Panel** to each corner of the **Front Wall** as shown. The **Corner Panel** should only be secured to the **Front Wall Panel** where the **Panels** overlap. Do not secure the **Corner Panel** to the **Front Wall** itself, this will be done in Step 6. Also, leave the holes closest to the **Door** open in the **Front Wall Panel**. These will be used to attach the **Door Jamb**s in Step 6.

## NOTE

Confirm Front Frame of Door Header Assembly is facing outside of building.

**IMPORTANT:** A minimum of two people should be used at all times when handling or maneuvering the Front Wall Assembly. When installing the Front Wall Assembly in the building, two people should hold the Assembly in place until it is secure. Failure to do so could result in bending the Front Frame and Fascia pieces.

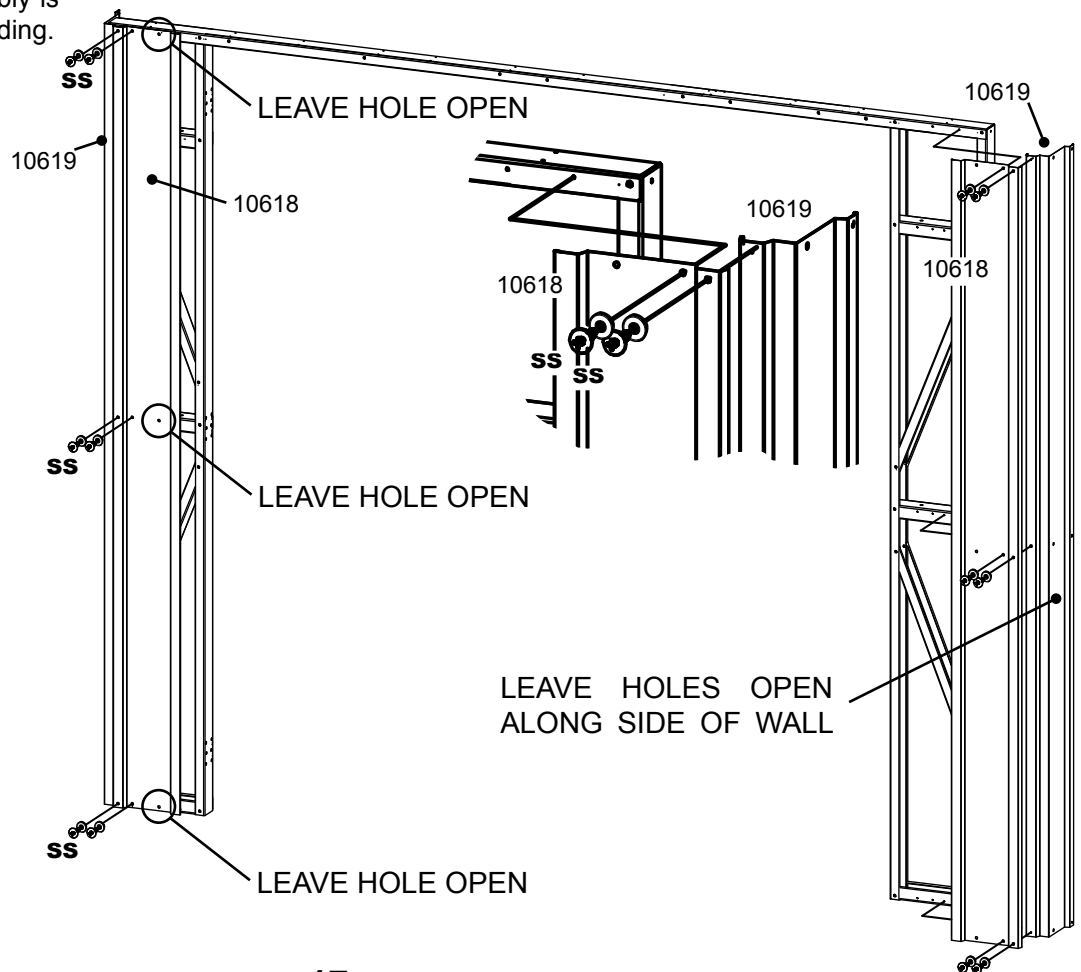

# Step 4: Truss Installation

You will need for this page:

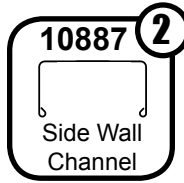
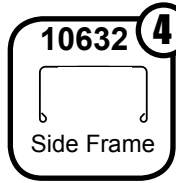
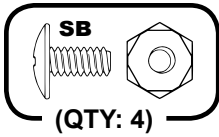
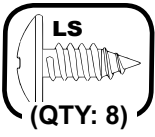

Assemblies from Step 1:

- Truss Assemblies (2)

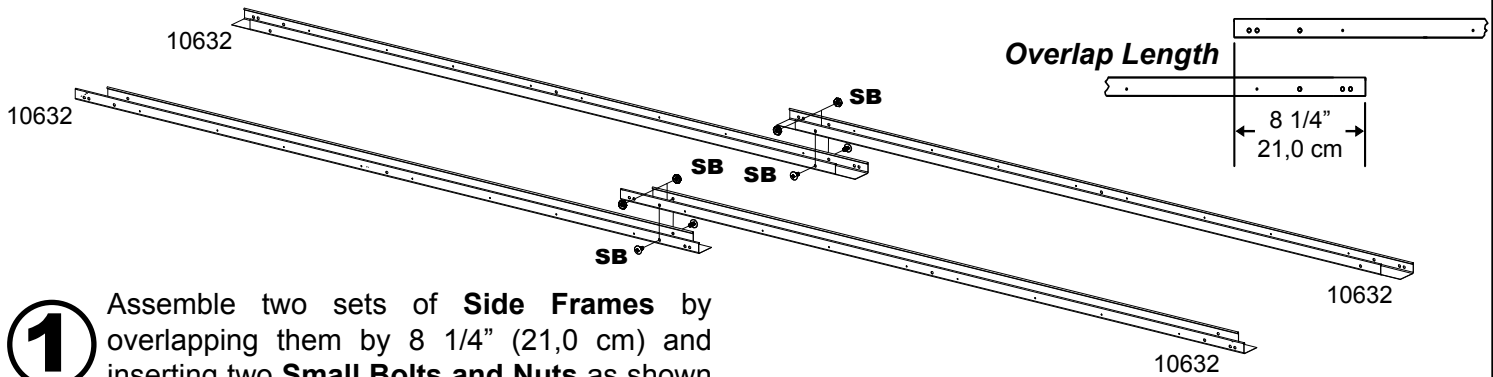

**1** Assemble two sets of **Side Frames** by overlapping them by 8 1/4" (21,0 cm) and inserting two **Small Bolts and Nuts** as shown above. These will form the left and right **Floor Frames**.

**2** 32 7/8" (83,5 cm) from the edge of each **Floor Frame**, erect a **Truss Assembly** and secure using a **Large Screw** on each side. Once two **Truss Assemblies** are in place, connect them with a **Mid Side Wall Channel** and secure with **Large Screws**. Support **Trusses** until **Mid Side Wall Channels** are in place.

Notched side of Frame must face inside building.

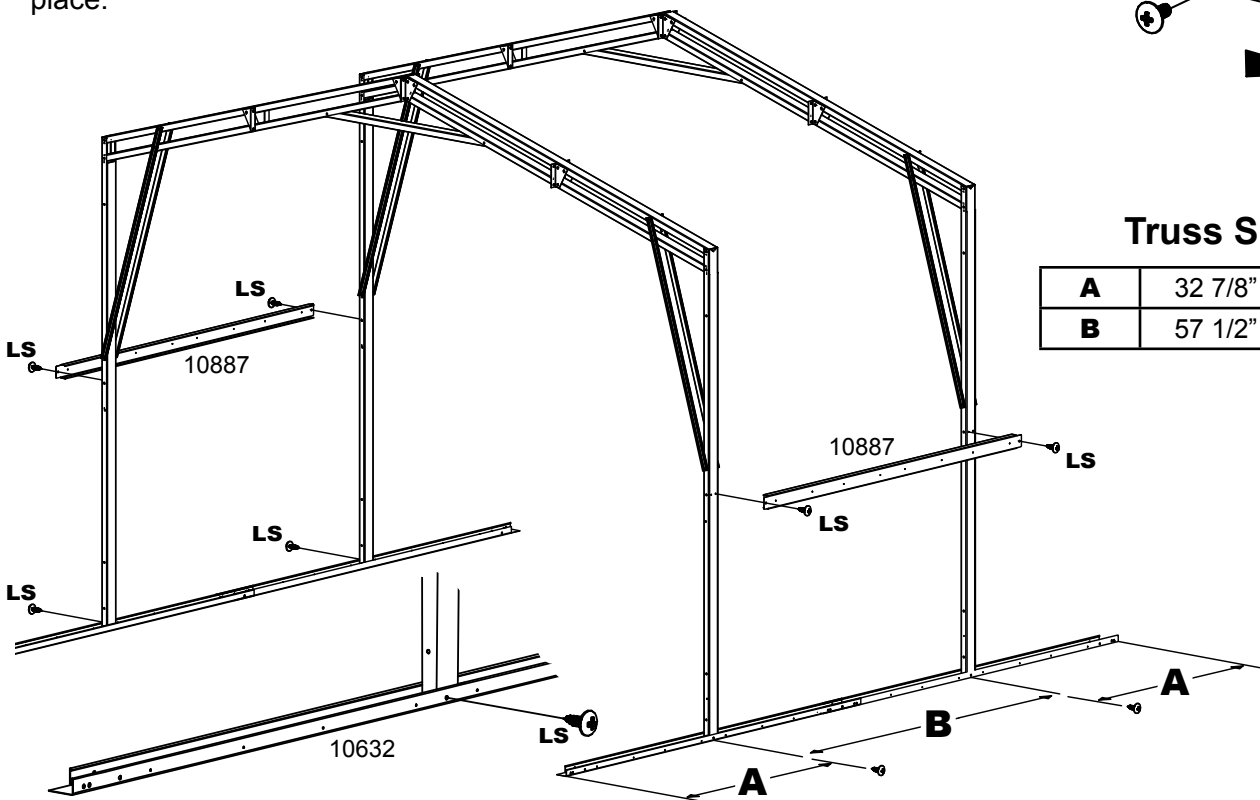
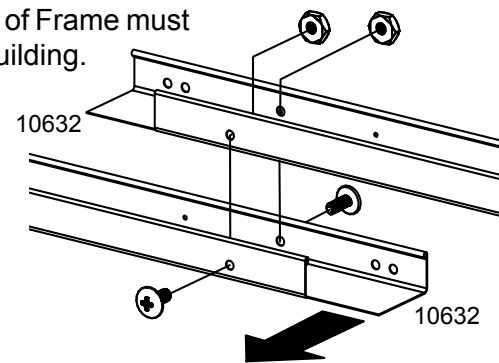

## Truss Spacing

<b>A</b>	32 7/8"	83,5 cm
<b>B</b>	57 1/2"	146,1 cm

# Step 4: Continued

You will need for this page:

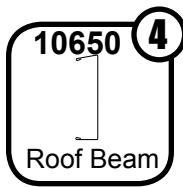
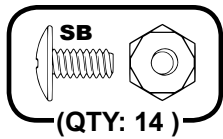

Side of Beams with small holes must face up.

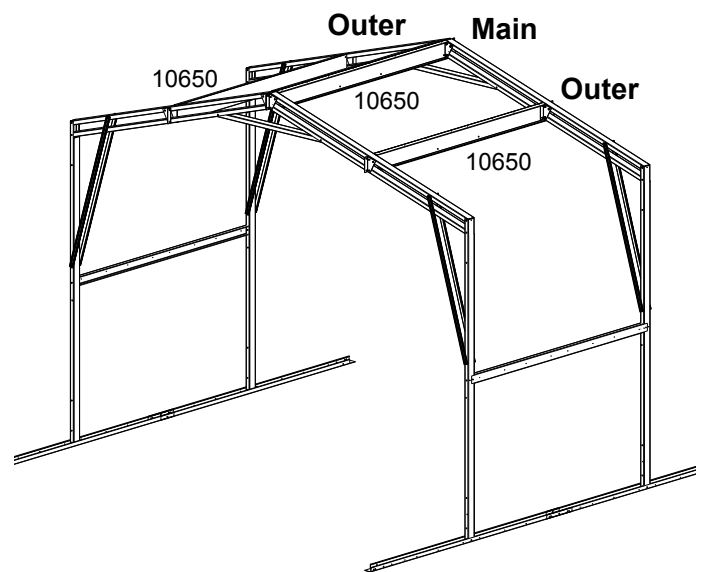
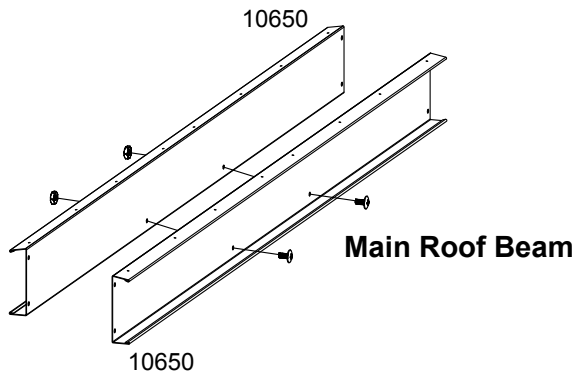
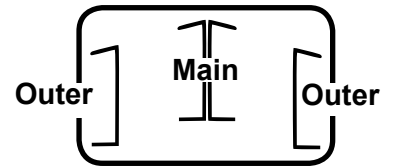
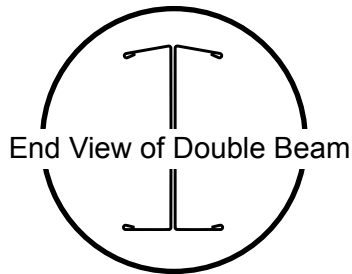

**3** Remove **Bolts** holding **Truss** peaks together (from Step 1-6). Next, place two **Middle Roof Beams** back-to-back and secure with two **Small Bolts** and **Nuts** as shown above. This is the **Main Roof Beam**.

**4** Install the **Main Roof Beam** and secure with two **Small Bolts** and **Nuts** at each end. Next, install the outer **Roof Beams** in the same manner.

Small holes in tops of beams.

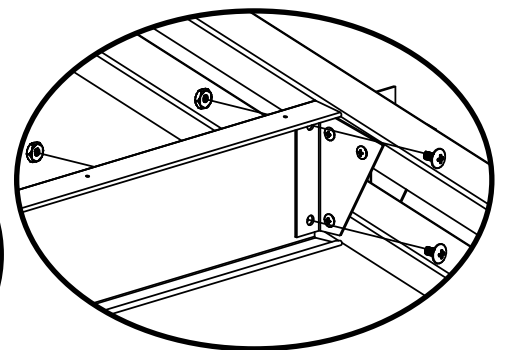
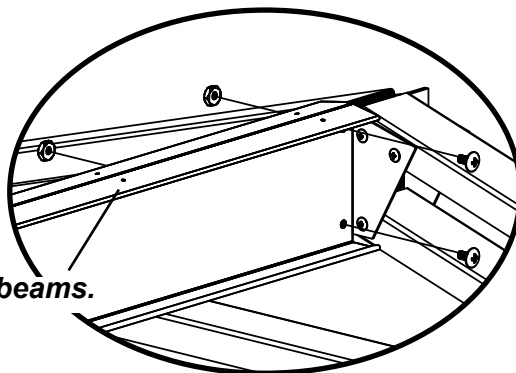

# Step 4: Continued for Extension Modules

You will need for this page:

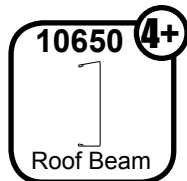
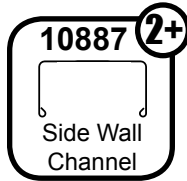
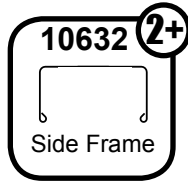
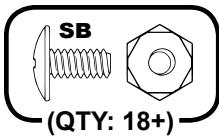
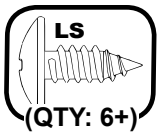

Assemblies from Step 1:

- All remaining Truss Assemblies

**NOTE** If you are erecting a 10'x10' (3.0 m x 3.1 m) building, skip this page and move on to page 21.

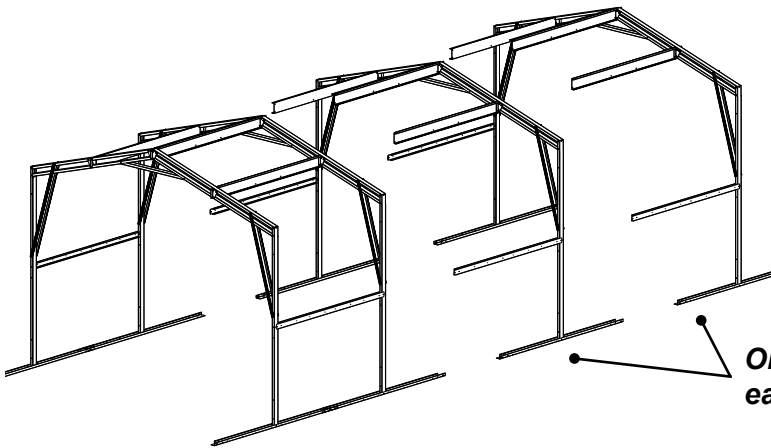

**5** All Truss Sections are assembled in the same manner as the Truss Section just erected. Install one additional Side Frame per side for each additional Module. Overlap Side Frames by 8 1/4" (21,0 cm). Refer to page 13 to see how many Trusses should be included in your building.

One Side Frame per side is added for each additional Extension Module.

**6** 57 1/2" (146,1 cm) behind the previous Truss, erect a Truss Assembly and secure using a Large Screw on each side. Once two Truss Assemblies are in place, connect them with a Mid Side Wall Channel and secure with Large Screws. Support Trusses until Mid Side Wall Channels are in place.

**7** Remove Bolts holding Truss peaks together (from Step 1-6). Next, place two Middle Roof Beams back-to-back and secure with two Small Bolts and Nuts as shown. This is the Main Roof Beam.

**8** Install the Main Roof Beam and secure with two Small Bolts and Nuts at each end. Next, install the outer Roof Beams in the same manner.

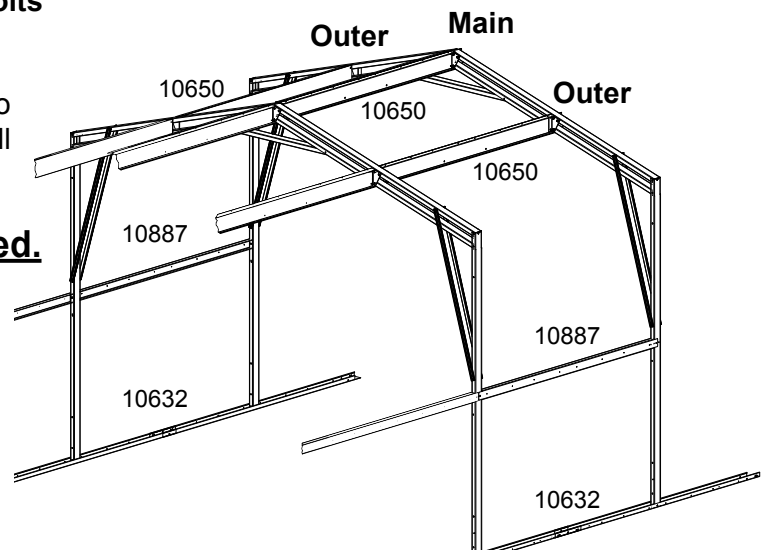
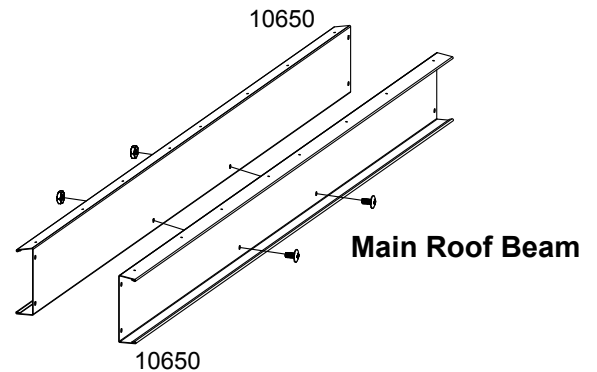

Repeat until all Trusses have been installed.

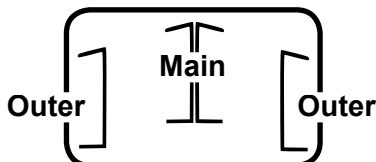

Side of Beams with small holes must face up.

# Step 5: Rear Wall Install

You will need for this page:

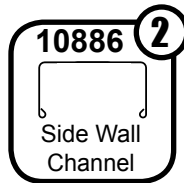
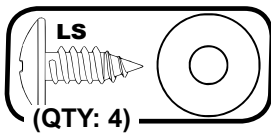
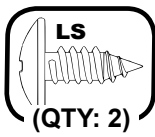

Assemblies from Step 2:

- Rear Wall Assembly

**NOTE** If you purchased a Door Kit, skip this page and move on to page 22.

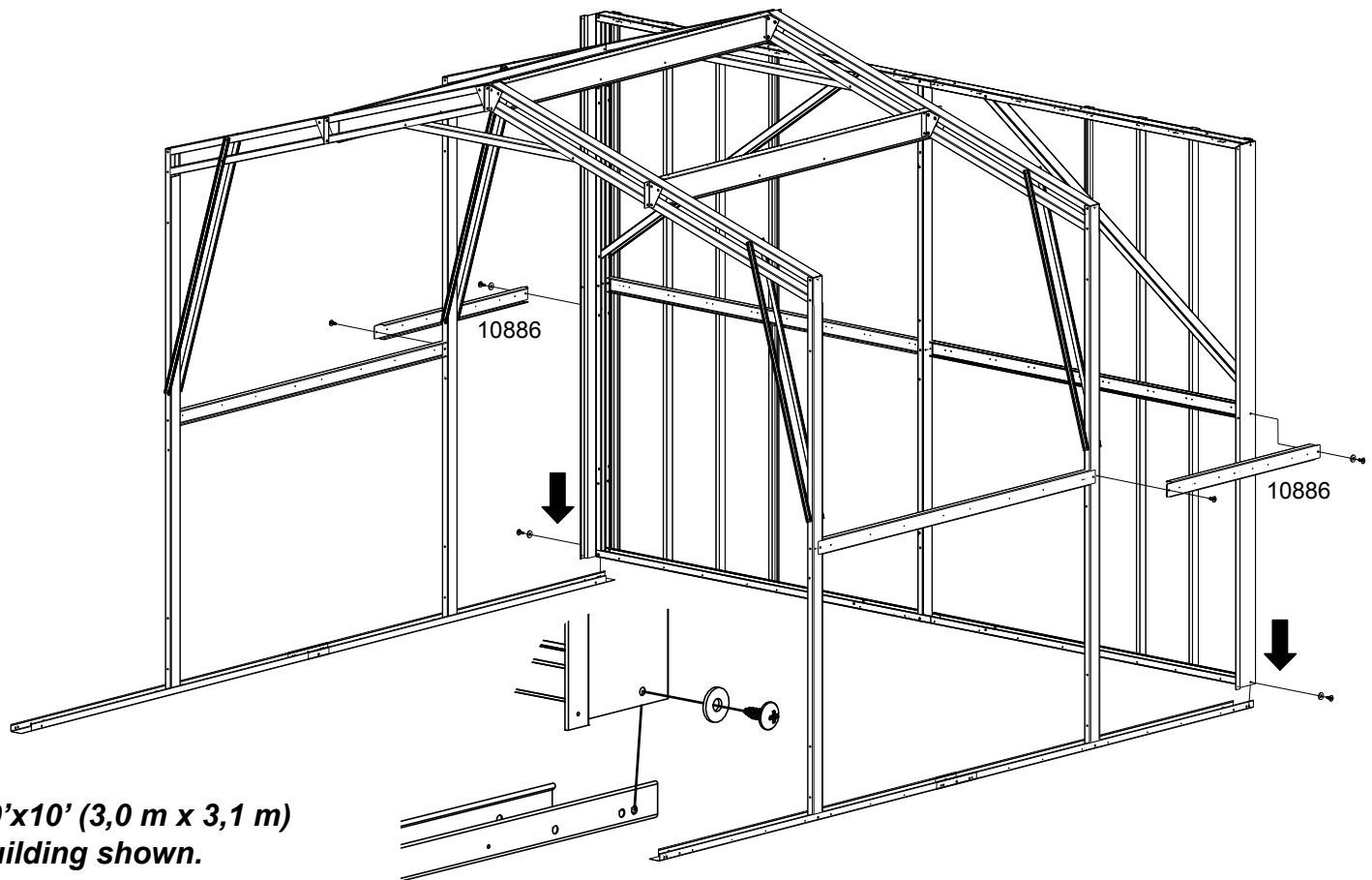

10'x10' (3,0 m x 3,1 m)  
building shown.

**1** Carefully position the **Rear Wall Assembly** in place at the rear of the building and secure to **Side Frame** with one **Large Screw** per side as shown.

**2** Slide one end of the **Front and Rear Side Wall Channel** behind the **Corner Panel** and secure with a **Large Screw**. Secure the other end with a **Large Screw** when done. Repeat for the other **Front and Rear Side Wall Channel**.

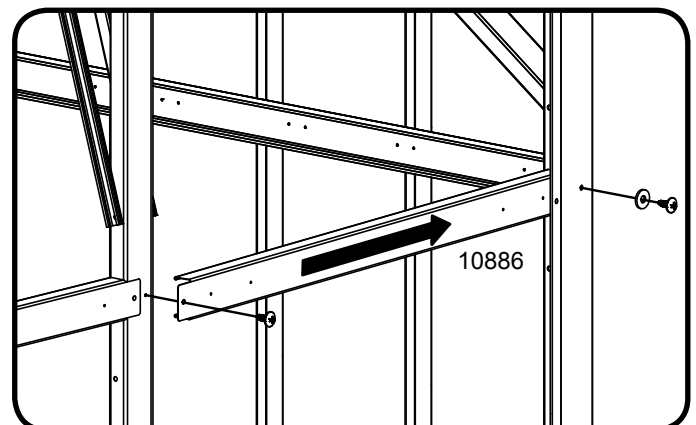

# Step 6: Front Wall Install

You will need for this page:

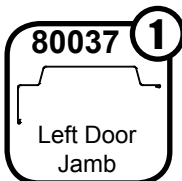
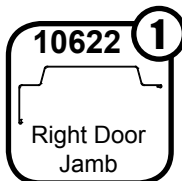
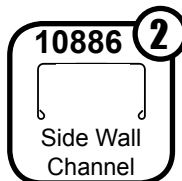
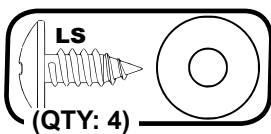
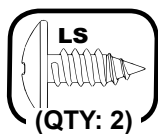

Assemblies from Step 3:

- Front Wall Assembly

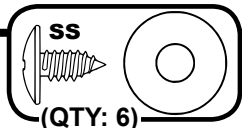

**NOTE** If you purchased a Door Kit, install second Front Wall Assembly on the rear of the building.

10'x10' (3,0 m x 3,1 m) building shown.

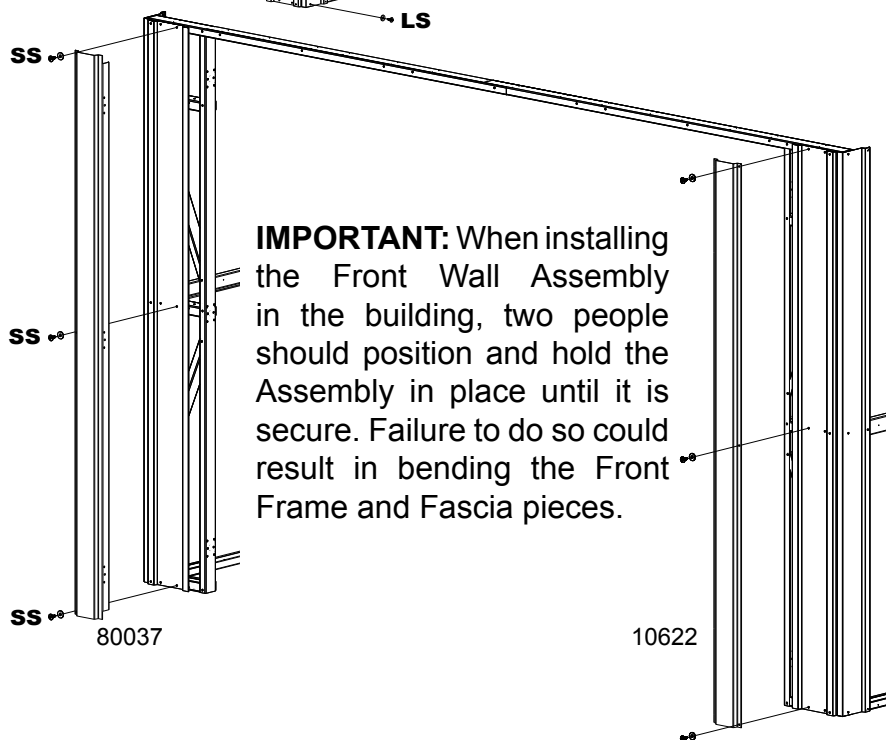
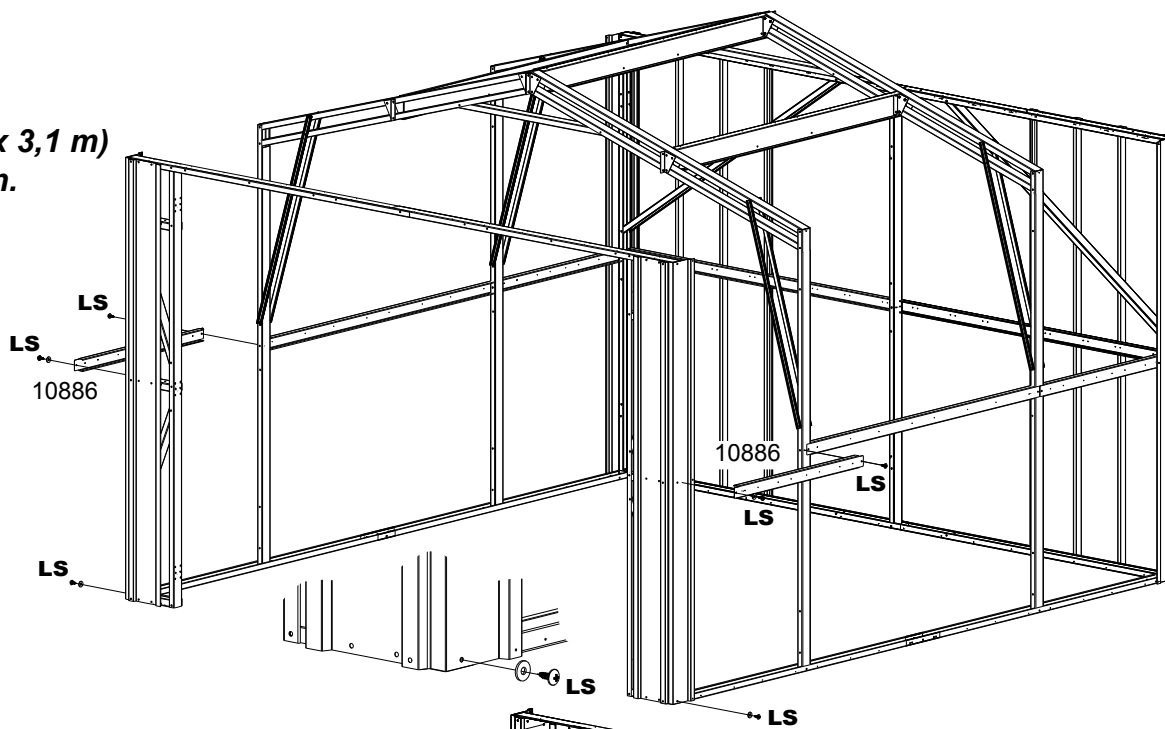

**1** Just as in the rear, carefully position the **Front Wall Assembly** as shown and secure with a **Large Screw** on both sides. Install **Front and Rear Side Wall Channels** using **Large Screws**.

**2** Position the **Door Jamb** as shown and secure to the **Front Wall Panel** using **Small Screws**. Double check that the holes in the **Door Jamb** line up with the holes in the **Wall Post (Hinge)**. If they do not, the **Left and Right Door Jamb** are most likely switched.

**IMPORTANT:** When installing the Front Wall Assembly in the building, two people should position and hold the Assembly in place until it is secure. Failure to do so could result in bending the Front Frame and Fascia pieces.

# Step 7: Wall Angles

You will need for this page:

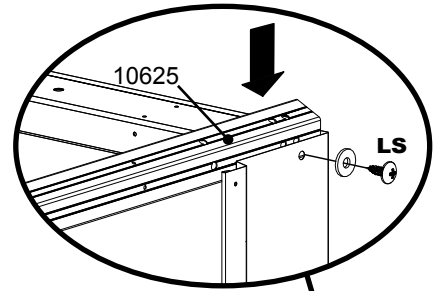
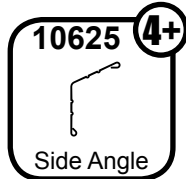
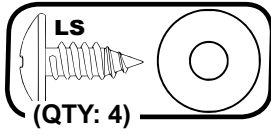
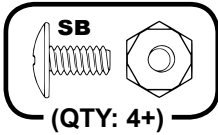
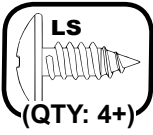

- 1 Starting at the front and rear of the building, attach **Side Wall Angles** to the front and rear wall of the building with **Large Screws** as shown.

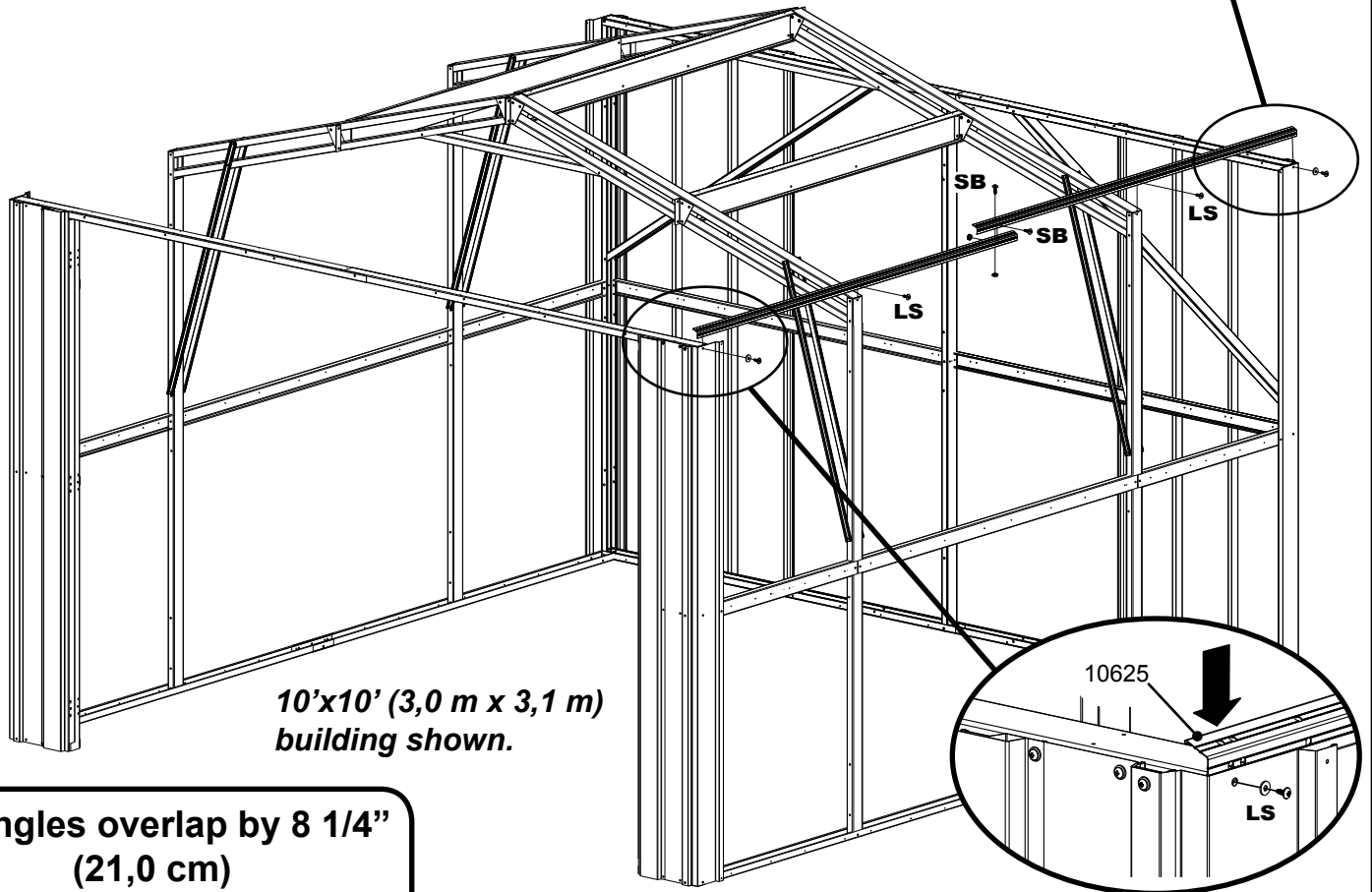

10'x10' (3,0 m x 3,1 m)  
building shown.

All angles overlap by 8 1/4"  
(21,0 cm)

Overlap Length

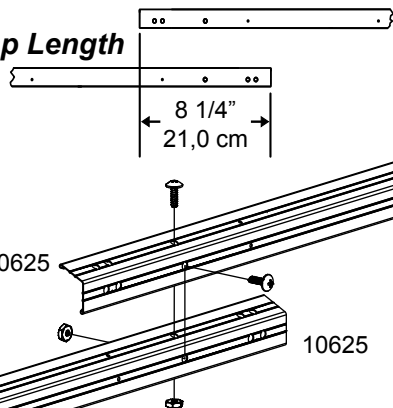

- 2 Next, insert **Large Screws** where the **Wall Angles** meet the **Trusses**. Where the **Wall Angles** overlap, align the holes as shown to the left and insert two **Small Bolts and Nuts** to secure. All **Side Wall Angles** overlap by 8 1/4" (21,0 cm).

**Continue until Side Wall Angles are installed along both sides of the building.**

# Step 8: Wall Panels

## **IMPORTANT:**

At this time, take a moment to ensure the building is level and square. Measure diagonally across the building from opposite corners; when these measurements match, the building is square. For the remainder of assembly it will be important that the building is both level and square.

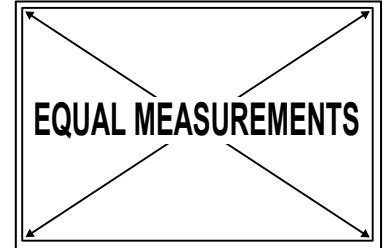

## **NOTE**

Whenever a crimped rib and an uncrimped rib meet, the crimped rib should be placed **UNDER** the uncrimped rib if possible. See next page.

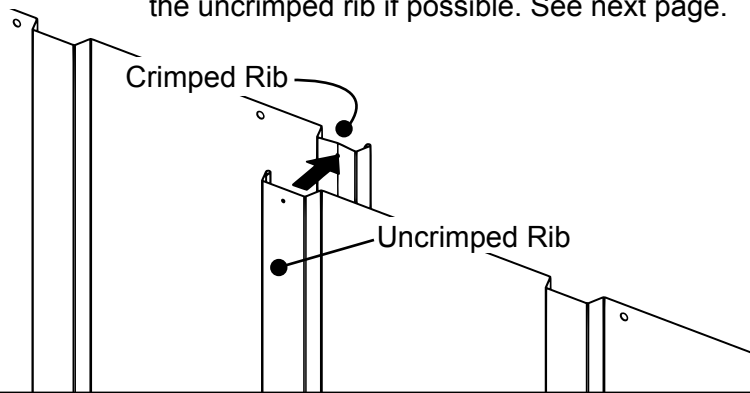

## **NOTE**

Use the diagram to the right when attaching Wall Panels.

- Secure the top row to Top Frames
- Secure the middle row to Wall Channels
- Secure the lower row to Floor Frames
- Secure the circled holes to the Panel next to it

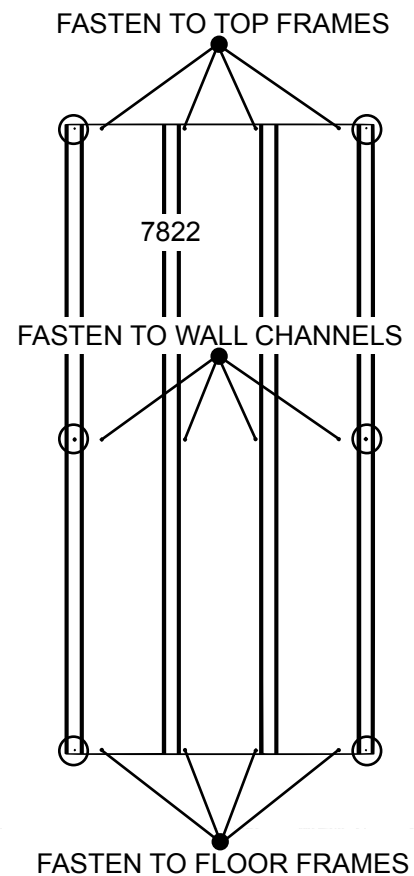

**IMPORTANT:** When installing the Wall Panels over a Truss, you will need to 'roll' the Panels as shown to be able to attach the next Panel at the overlap. When securing the Panel to the building with Small Screws, do not insert Screws in the row of holes closest to the last rib of the Panel. Next, roll the Panel back slightly and attach the next Panel at the overlap with a Small Bolt and Nut in the center hole. Once this is done, continue securing the Panel to the building.

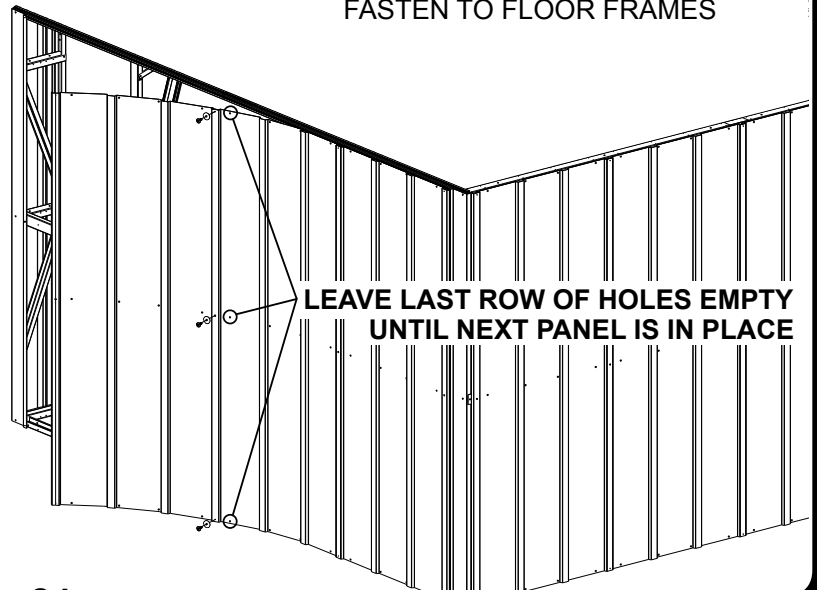



# Step 8: Continued

You will need for this page:

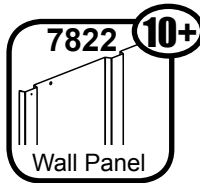
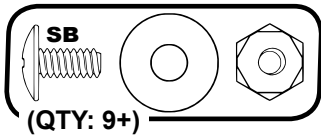
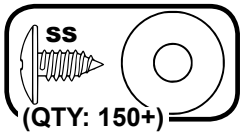

10'x10' (3,0 m x 3,1 m)  
building shown.

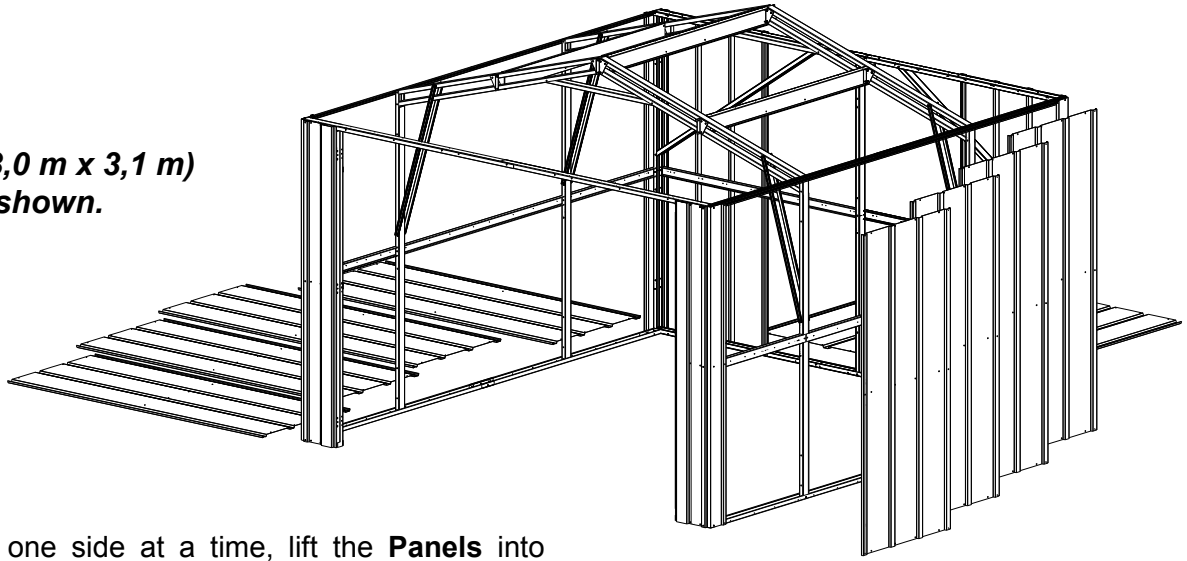

**1** Working one side at a time, lift the **Panels** into place and secure with three **Small Screws** in the top of the **Panel**, three **Small Screws** in the middle of the **Panel**, and three **Small Screws** in the bottom of the **Panel**. Roll the **Panel** back as shown on the previous page and overlap the rib with the rib of the next **Panel**.

**2** Secure the **Panels** with a **Small Bolt and Nut** thru the center hole at the overlap (see below). Next, finish securing the **Panels** to the building with **Small Screws** as shown in the diagram on the previous page. **Note:** When attaching to **Corner Panels**, use **Small Screws**.

**Continue until ALL Wall Panels have been installed.**

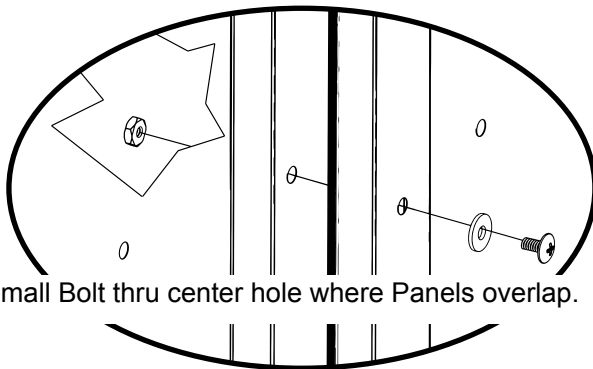

Place Small Bolt thru center hole where Panels overlap.

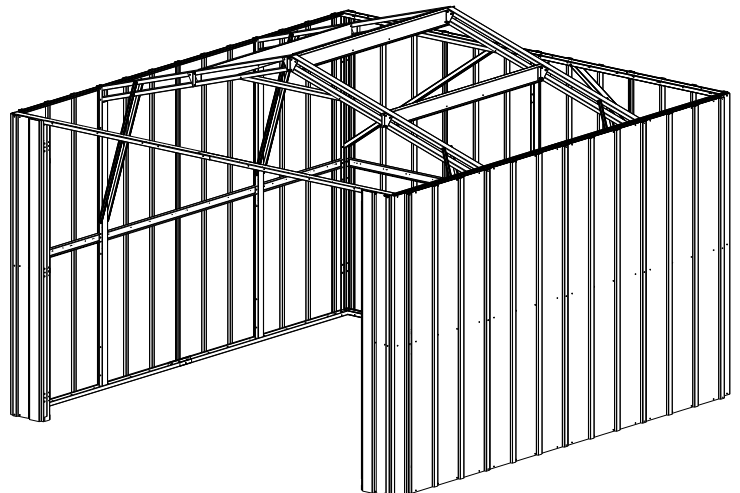

# Step 9: Gables

You will need for this page:

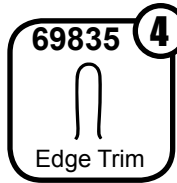
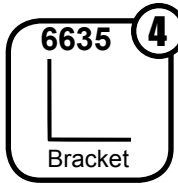
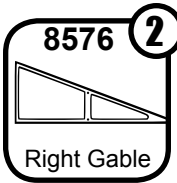
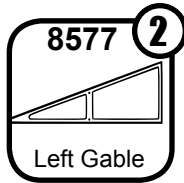
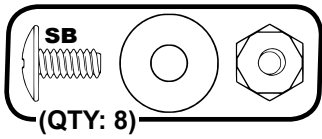

**STOP**

GABLES ARE STACKED TOGETHER DURING SHIPPING AND MAY BE MISTAKEN FOR ONE GABLE! SEPARATE GABLES BEFORE CONTINUING.

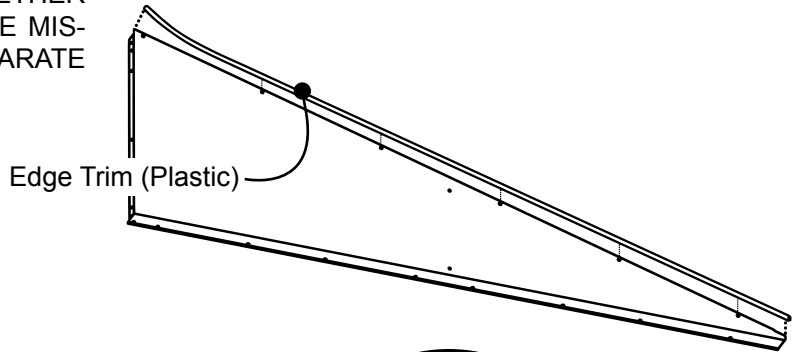
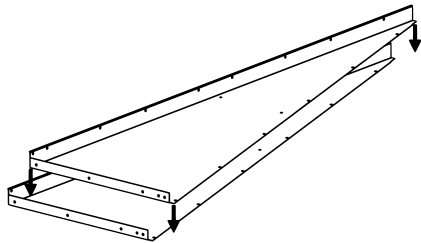

Edge Trim MUST cover Gable edge.

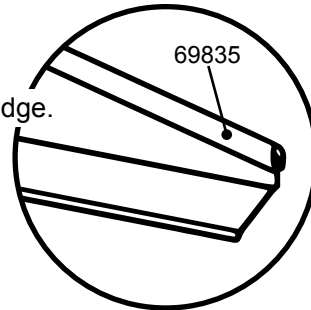

**Install Edge Trim to cover Gable Edge BEFORE doing ANY work with Gables. Failure to do so could result in injury.**

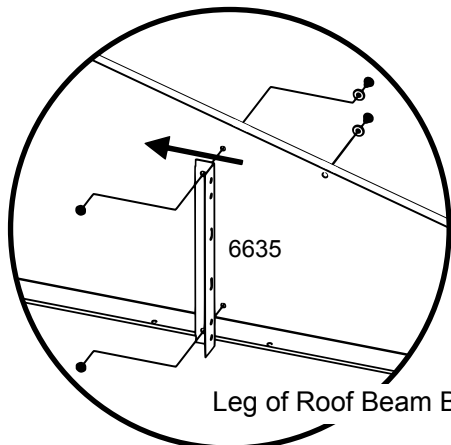
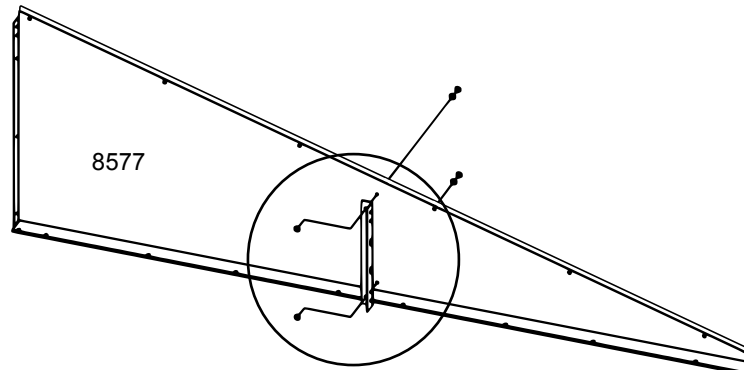
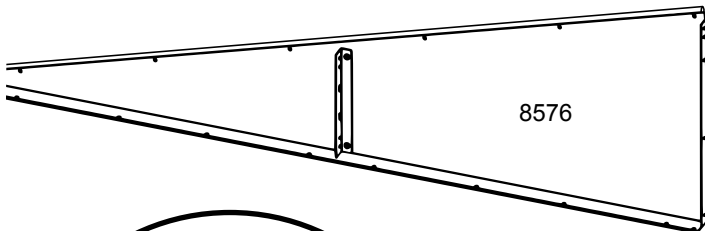

Leg of Roof Beam Bracket must face center of Gable as shown.

**1**

Install **Roof Beam Brackets** on all **Gables** using two **Small Bolts and Nuts** per **Bracket**. Leg of **Bracket** must face center of **Gable** as shown.

# Step 9: Continued

You will need for this page:

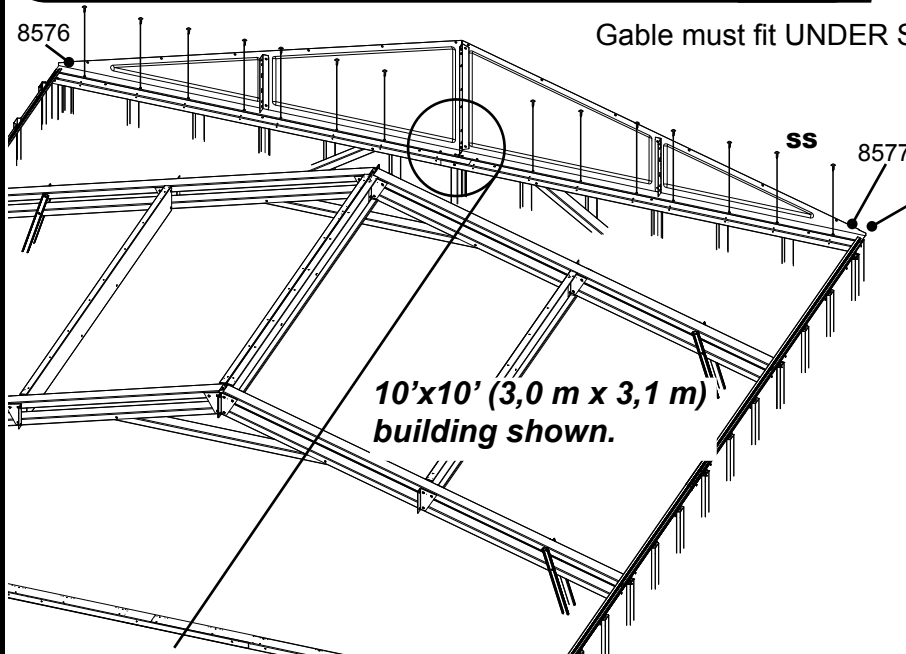
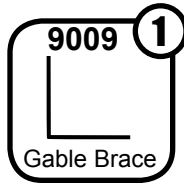
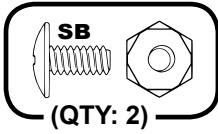
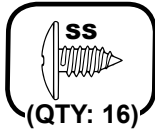

Gable must fit UNDER Side Wall Angle at corner.

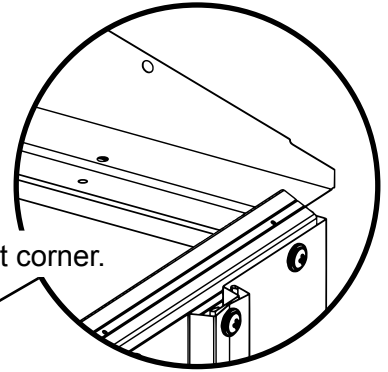

**2** Working with one **Gable** at a time, attach the **Gables** to the top **Rear Frame** with **Small Screws**. The **Gable** should be attached using the row of holes closest to the outside of the building. Do not insert screws into the two holes closest to where the **Gables** join. These will be used to attach the **Track Support** later.

**3** To secure **Gables** together, position the **Gable Brace** as shown below and insert a single **Small Bolt and Nut** through the second hole from the bottom only.

Leave two holes open on each side of the Gable peak to attach Track Support.

Attach Gable to holes closest to the Outside of the building.

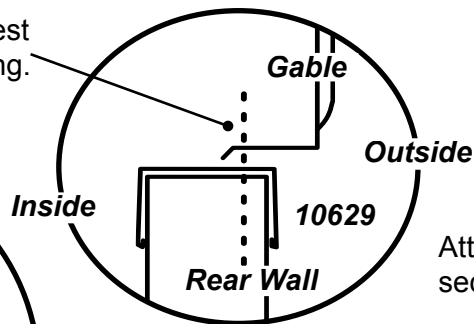

Attach Brace with Bolt thru second hole from bottom only.

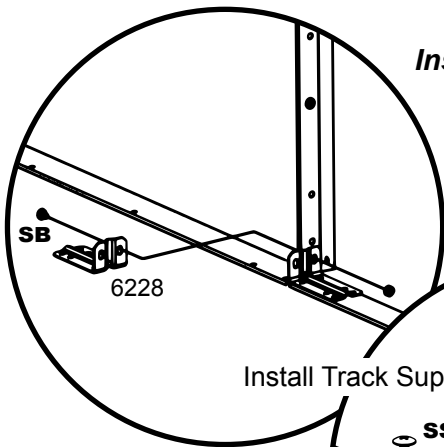
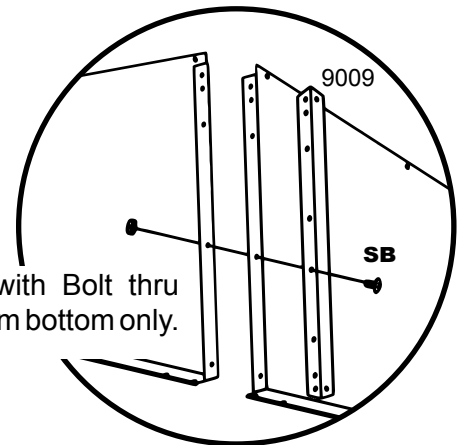

Install Track Support.

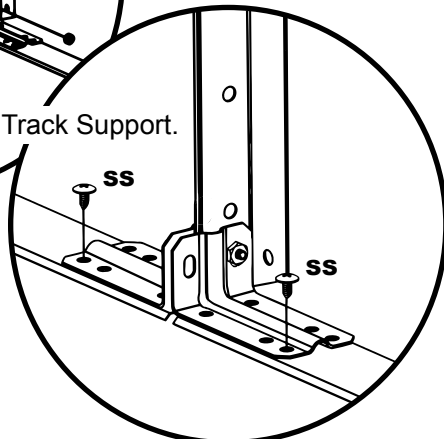

**4** Position **Track Supports** as shown. Secure **Track Supports** to **Gable** using one **Small Bolt and Nut**. Secure to **Rear Frame** using two **Small Screws**.

# Step 9: Continued

You will need for this page:

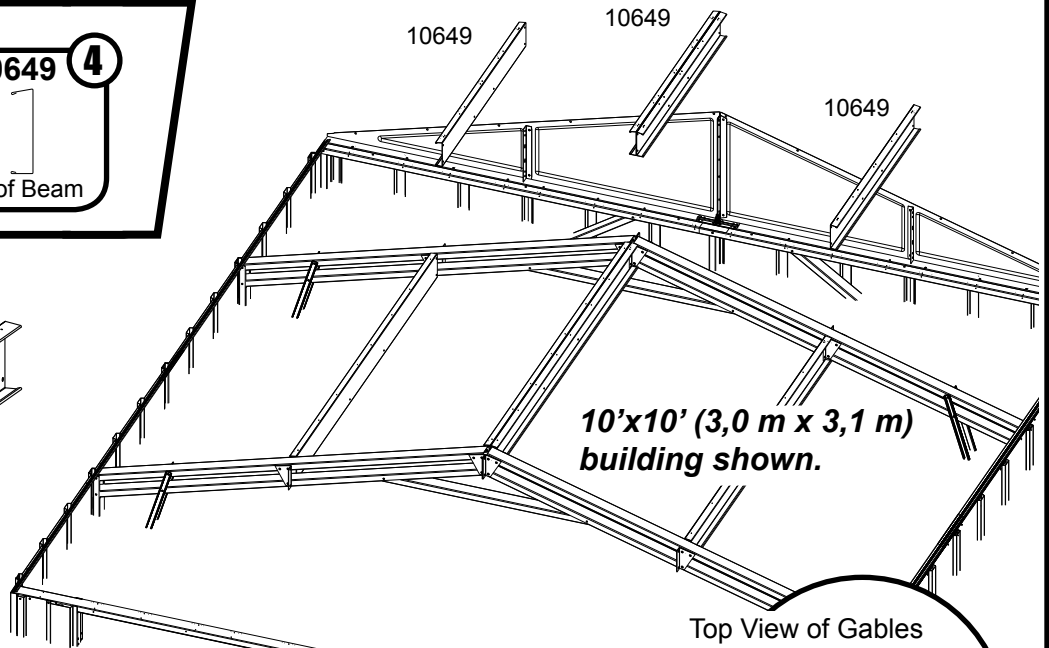
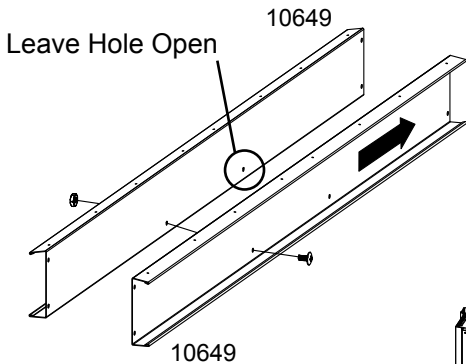
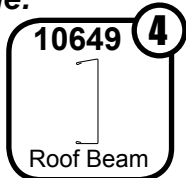
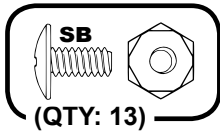

Top View of Gables

**5** Seal the gap between the **Gables** using the **Weather Stripping Tape** as shown.

**6** Secure two **Front and Rear Roof Beams** together with a single **Bolt** to form the **Main Roof Beam** as shown above. The end of the **Main Roof Beam** with the open hole should face the **Gable**.

**7** Position the **Front and Rear Roof Beams** as shown below and attach to **Gable and Truss** using two **Small Bolts and Nuts** per side. Install the **Main Beam** first.

Tape should wrap around gap between Gables.

Weather Stripping Tape

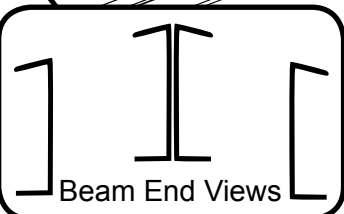
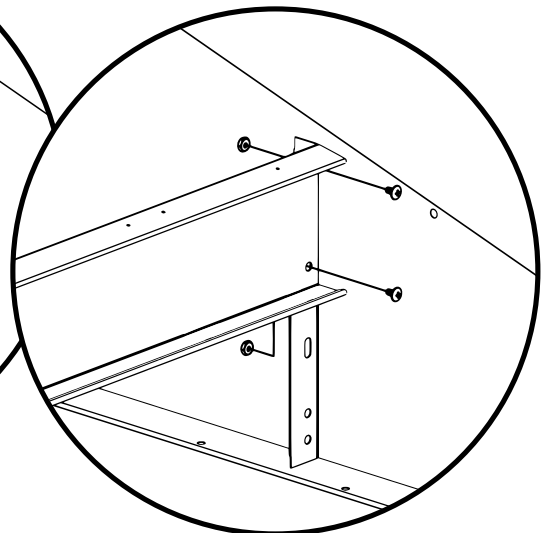
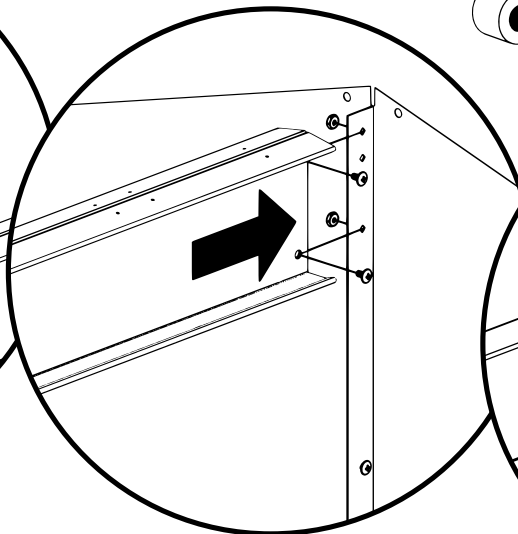
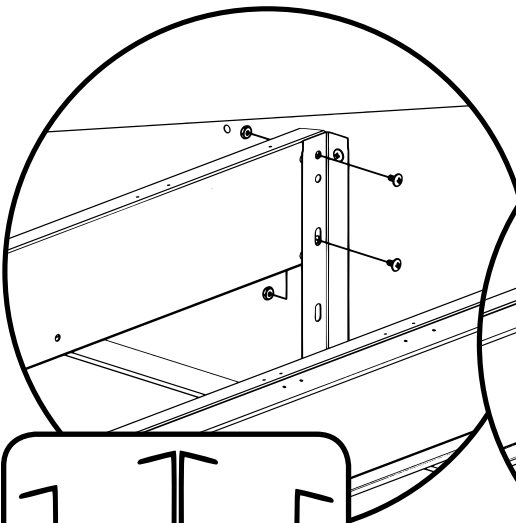
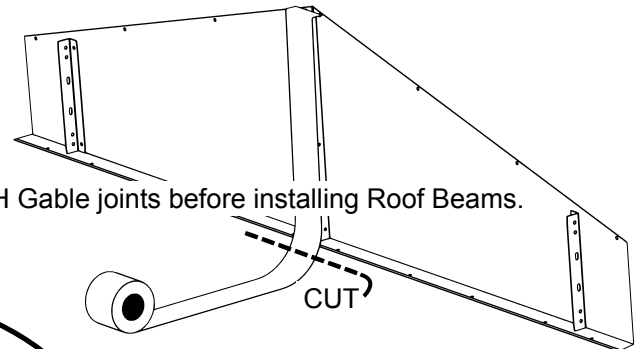
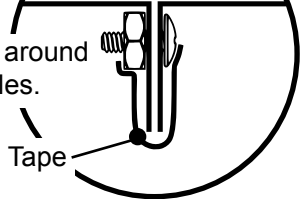

Side of Beams with small holes must face up.

# Step 9: Continued

You will need for this page:

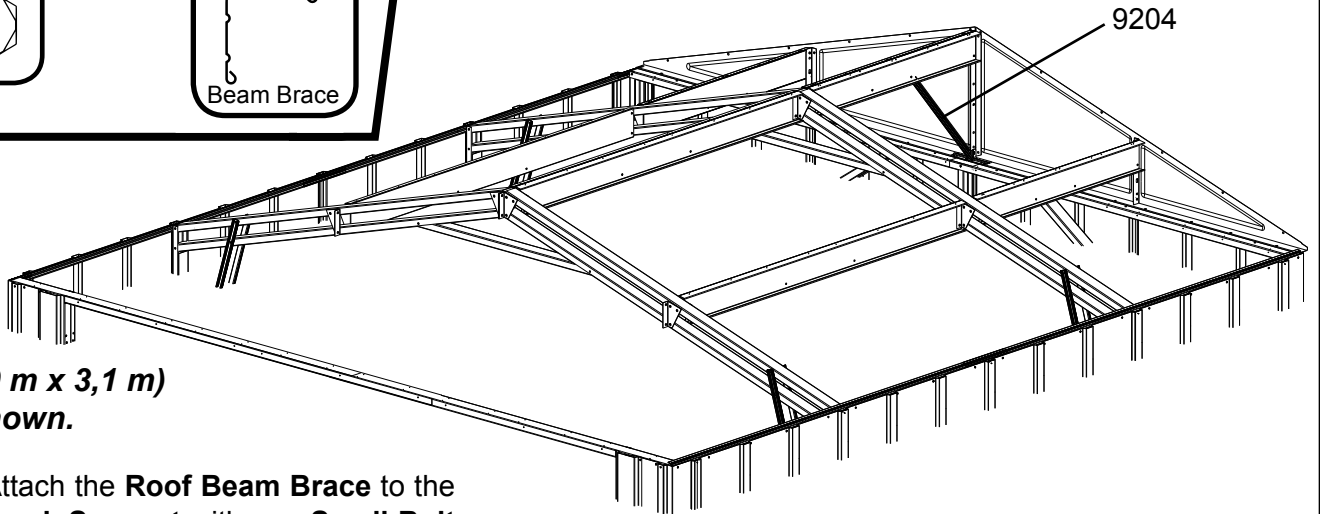
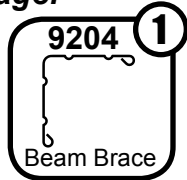
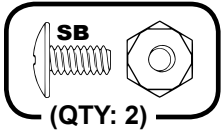

10'x10' (3,0 m x 3,1 m)  
building shown.

**8** Attach the **Roof Beam Brace** to the **Track Support** with one **Small Bolt and Nut** as shown.

**9** Rotate to align with **Roof Beam** and secure to **Roof Beam** with one **Small Bolt and Nut** as shown.

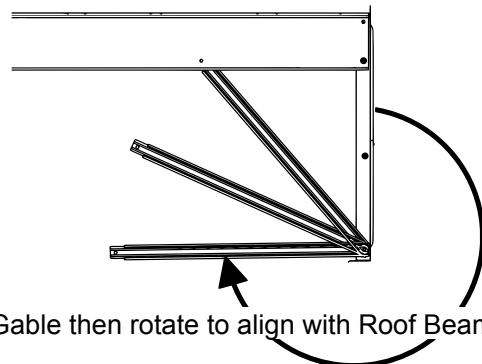
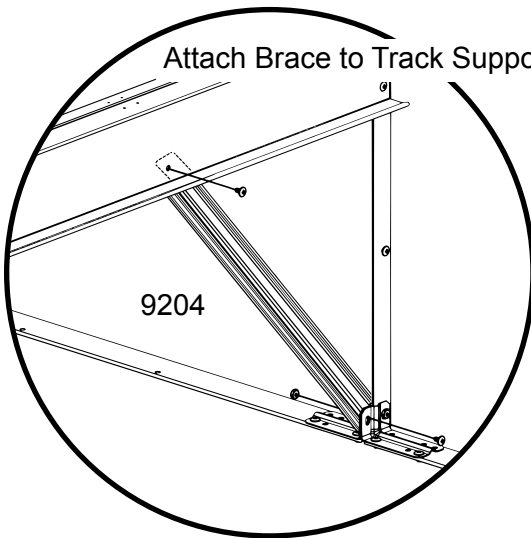
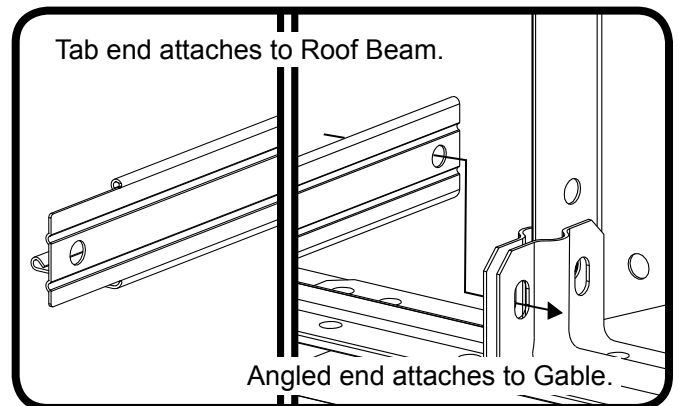

**10** Working with one **Gable** at a time, attach the **Gables** to the top **Front Header** with **Large Screws**. Do not insert screws into the two holes closest to where the **Gables** join. These will be used to attach the **Track Support** later. Repeat Steps 9-3 thru 9-9 to install **Gables** at the front of the building.

# Roof Install Prep Page

*Read thru all of Roof Assembly before beginning Step 10.*

**IMPORTANT:** At this time, take a moment to ensure the building is level and square. Measure the building diagonally again to make sure the building is square. The building should be square at the base and at the top. This will make Roof Panels fit better and holes will better align.

**NOTE** Be sure to carefully follow the Roof Panel Placement Order Diagram on this page.

**NOTE**

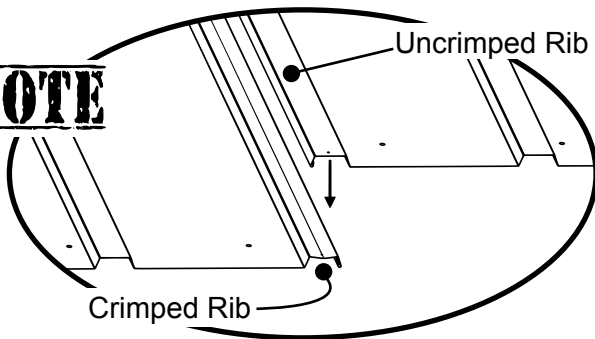

Whenever a crimped rib and an uncrimped rib meet, place the crimped rib UNDER the uncrimped rib.

The building is square when diagonal measurements are equal.

**don't focus weight on roof**

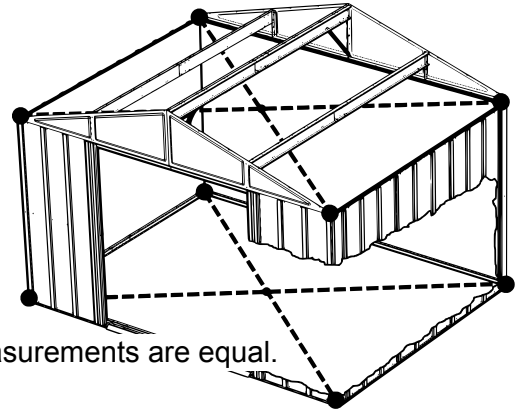
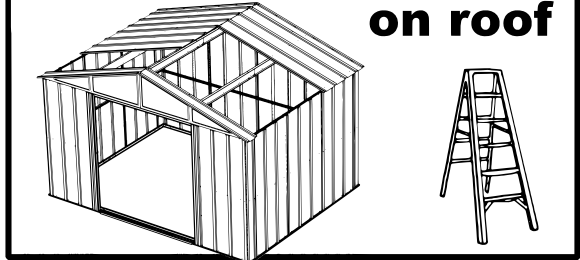

## Roof Panel Placement Order

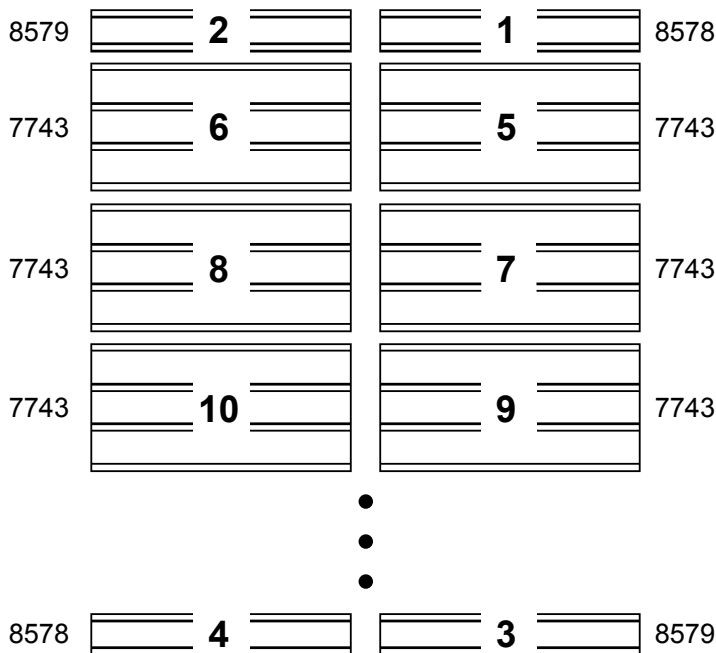

**FRONT**

FASTEN TO RIDGE CAP

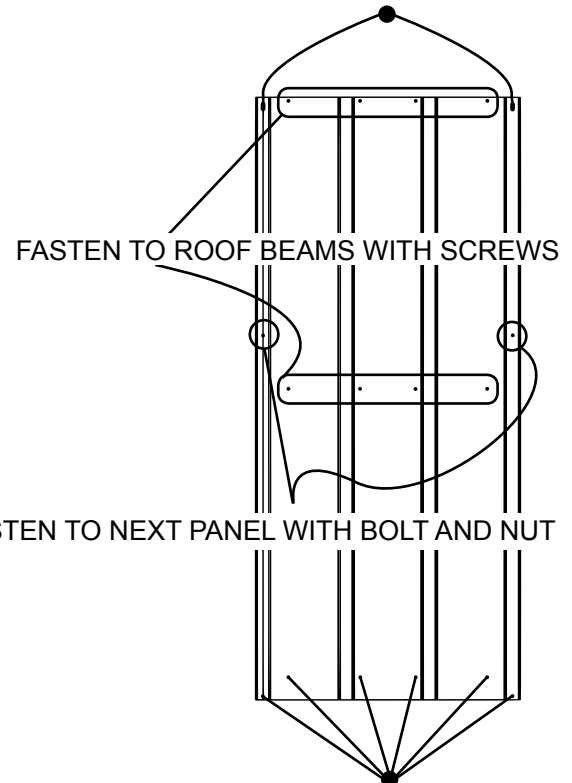

DO NOT FASTEN AT THIS TIME

# Step 10: End Panels

You will need for this page:

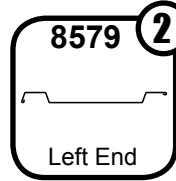
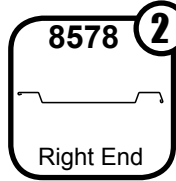
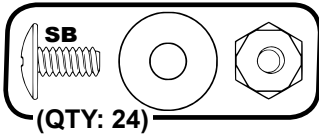
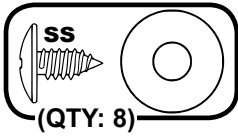

**1** Secure the **End Panel** to the **Main Roof Beam** by placing a **Small Screw** in hole #1 (from the diagram below). Carefully remove the **Gable Edge Trim** once the **Panel** is in position.

**2** Fasten **Panel** to **Gable** by placing **Small Bolts and Nuts** through holes #2 - #7. Fasten the holes in order.

**3** Secure the **Panel** to the outer **Roof Beam** by placing a **Small Screw** in hole #8. Repeat for other three **End Panels**.

An Awl may be used to help align holes that are only slightly misaligned. Take care not to bend or warp the metal, and always practice proper tool safety.

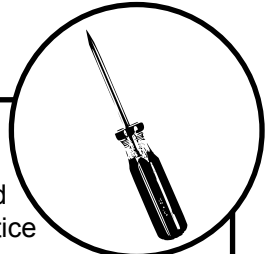

**NOTE** If Roof Beam holes do not line up with Roof Panel holes, shift the building from left to right. If this does not help, your building may not be level. Shim the corners until holes line up.

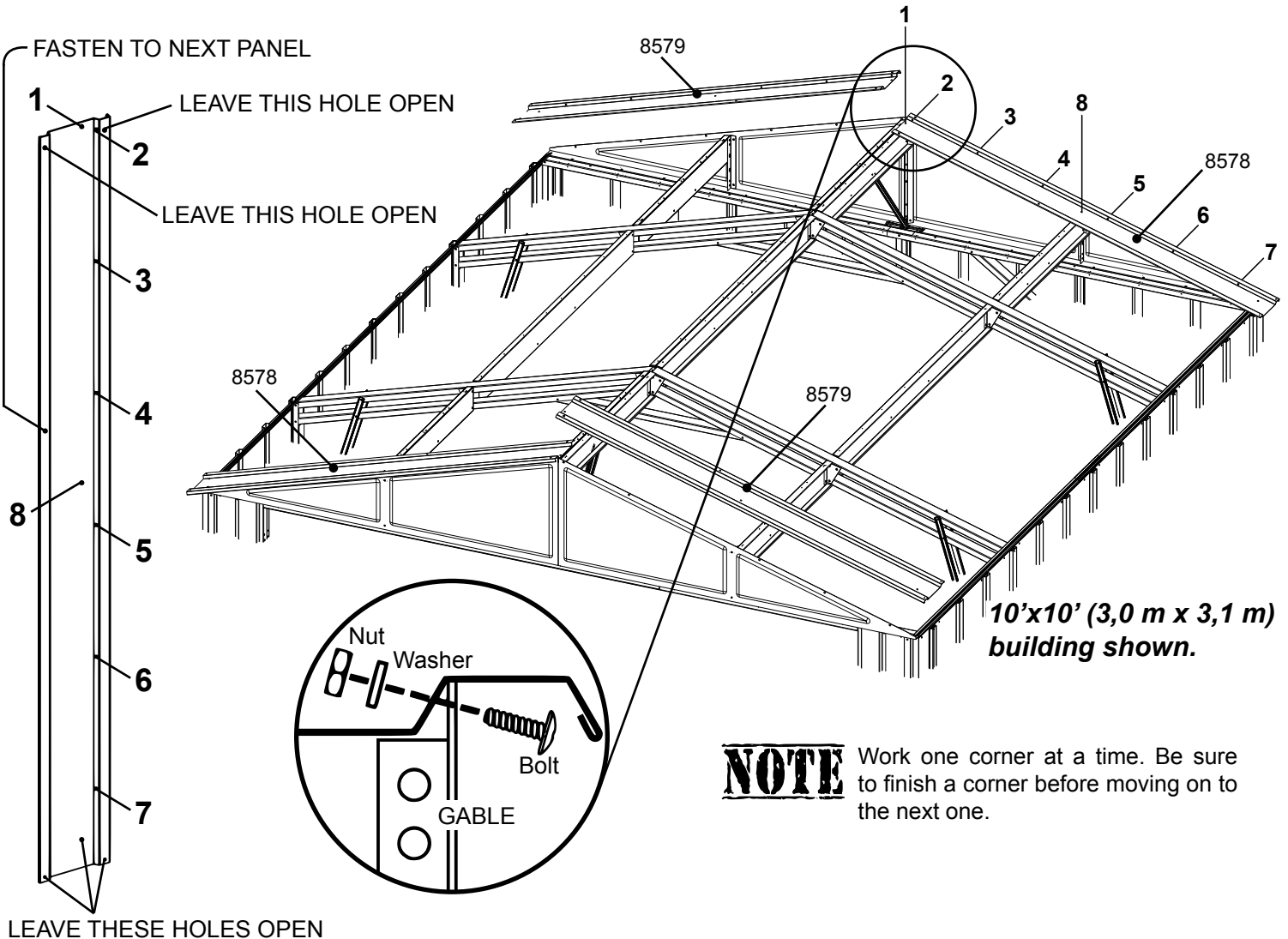

**NOTE** Work one corner at a time. Be sure to finish a corner before moving on to the next one.

# Roof Assembly Chart

10'x10'  
(3,0 m x 3,1 m)

No Extension  
Modules.

 = 4

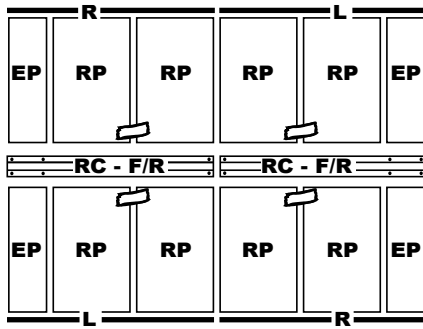

EP = End Panel (8578 / 8579)

RP = Roof Panel (7743)

RC - F/R = Front and Rear Ridge Cap (10621)

RC - MID = Mid Ridge Cap (10680)

L = Left Roof Trim (80017)

R = Right Roof Trim (10620)

M = Mid Roof Trim (6015)

 = Strip of Tape

10'x15'  
(3,0 m x 4,6 m)

1 Extension  
Module.

 = 6

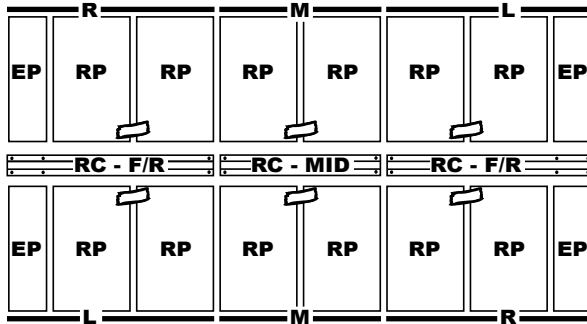

**NOTE:** The symbol  indicates a 2" (5,1 cm) strip of Weather Stripping Tape. Cut the number of strips indicated for your size building and set aside for later use.

10'x20'  
(3,0 m x 6,1 m)

2 Extension  
Modules.

 = 8

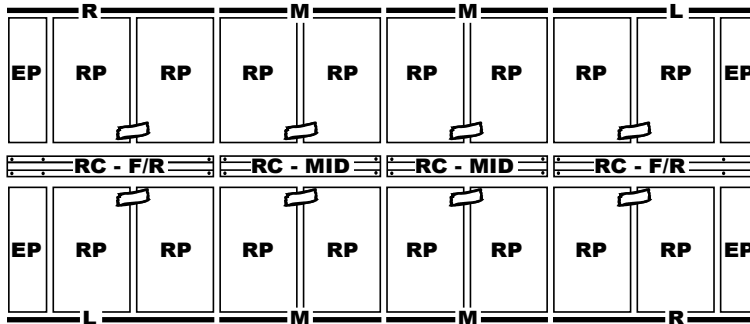

10'x25'  
(3,0 m x 7,5 m)

3 Extension  
Modules.

 = 10

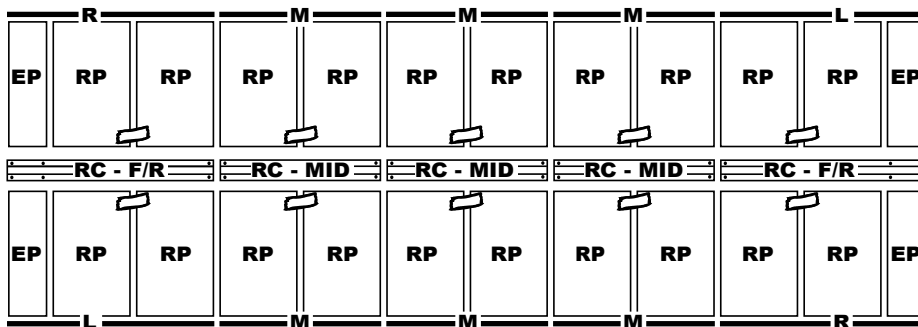

10'x30'  
(3,0 m x 9,0 m)

4 Extension  
Modules.

 = 12

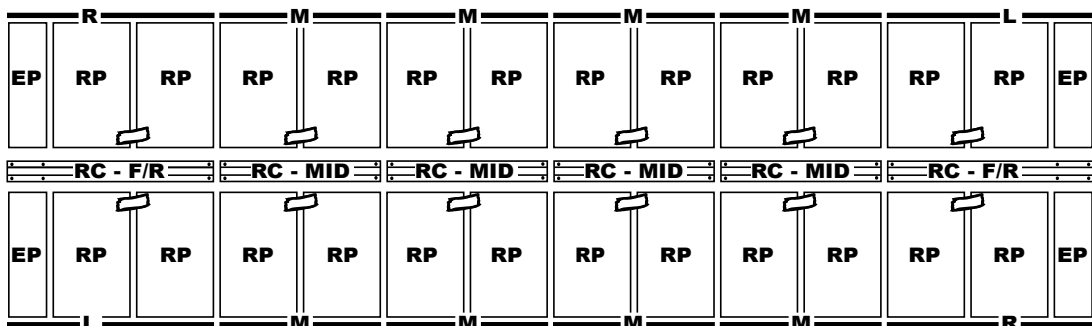

← FRONT

REAR →



# Step 11: Roof Assembly

You will need for this page:

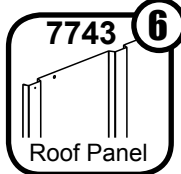
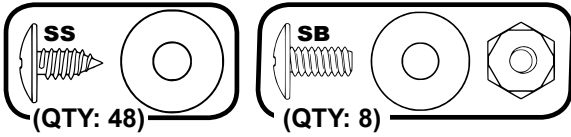

• Starting with rib #5 below, every rib that is over a Truss should be secured with a Small Bolt and Nut, and then sealed with a strip of Tape.

**1** Begin weather stripping the roof ridge. Apply more of the **Weather Stripping** after each additional **Panel** is installed. A strip of **Weather Stripping Tape** 2" (5,1 cm) long should be applied over each **Bolt** that is on a rib overlap and under the **Ridge Cap**.

**2** Attach the first four **Panels** (#5 - #8) in the order given in the diagram on page 30. Use the **Roof Panel Diagram** on page 30 while assembling the roof. You will need to 'roll' the **Panels** to secure the ribs together, just as on **Wall Panels**.

**3** Secure rib #5 with two **Small Bolts and Nuts** as shown to the right, and then cover with two 2" (5,1 cm) strips of **Weather Stripping Tape**.

**4** Install **Panels** #9 - #10 and seal with **Weather Stripping Tape**.

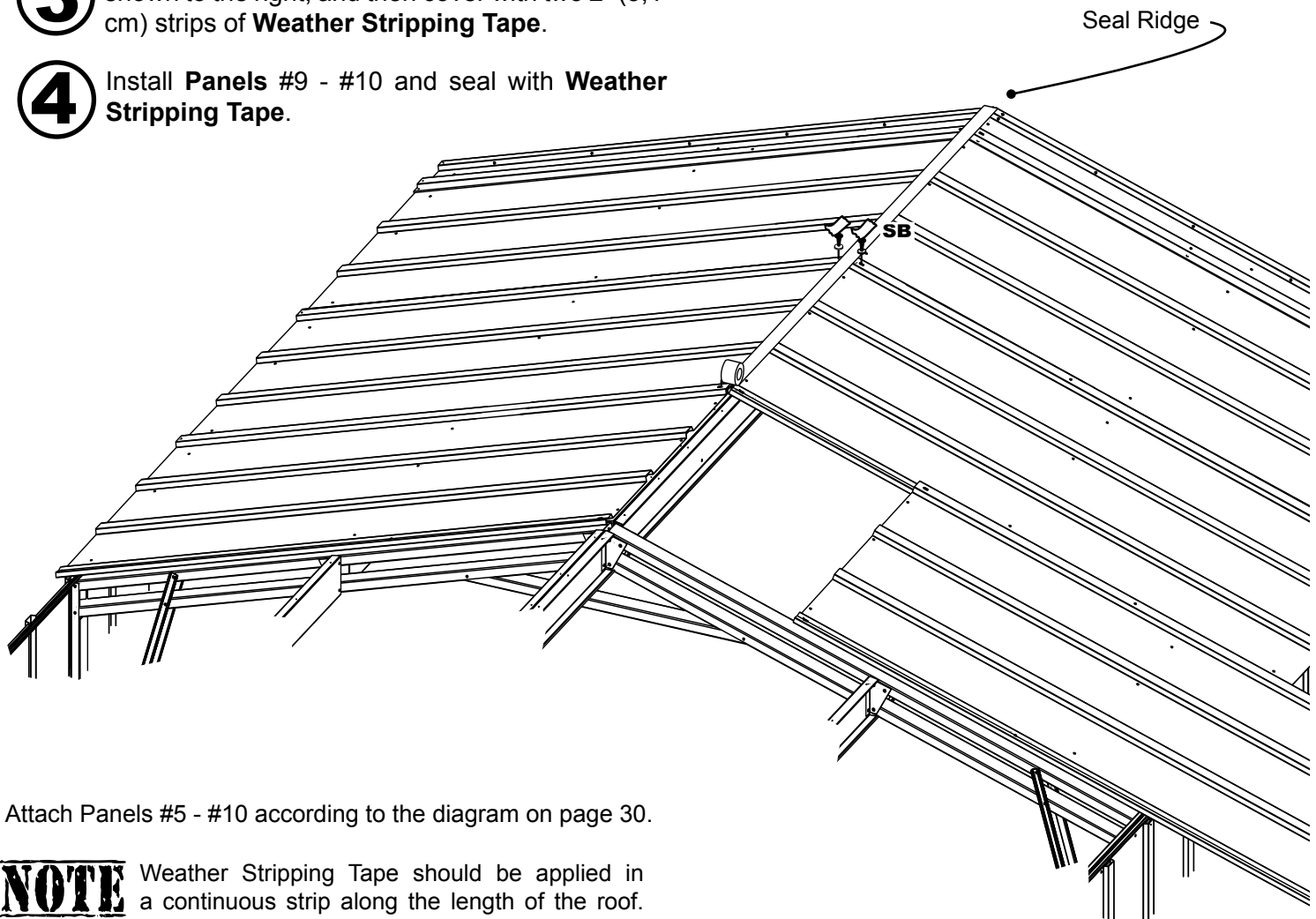
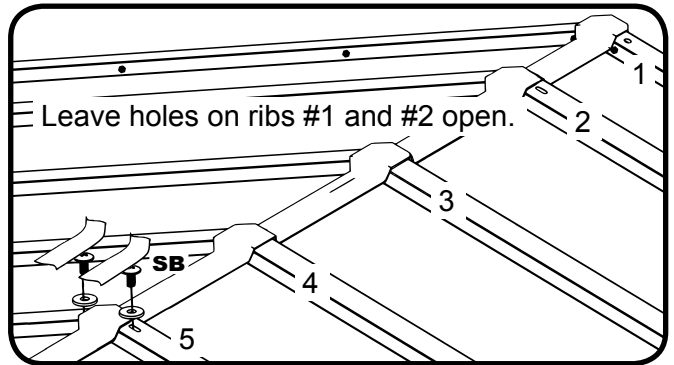

Attach Panels #5 - #10 according to the diagram on page 30.

**NOTE** Weather Stripping Tape should be applied in a continuous strip along the length of the roof.

# Step 11: Continued

**For 10'x10' (3.0 m x 3.1 m) ONLY.**

- 5** Overlap two **Front and Rear Ridge Caps** as shown and secure with two **Small Bolts and Nuts**.

**NOTE** DO NOT fully tighten Ridge Cap Bolts until you have both Ridge Cap Bolts in place. This will ease assembly. Bolts must be fully tightened before moving on to the next page.

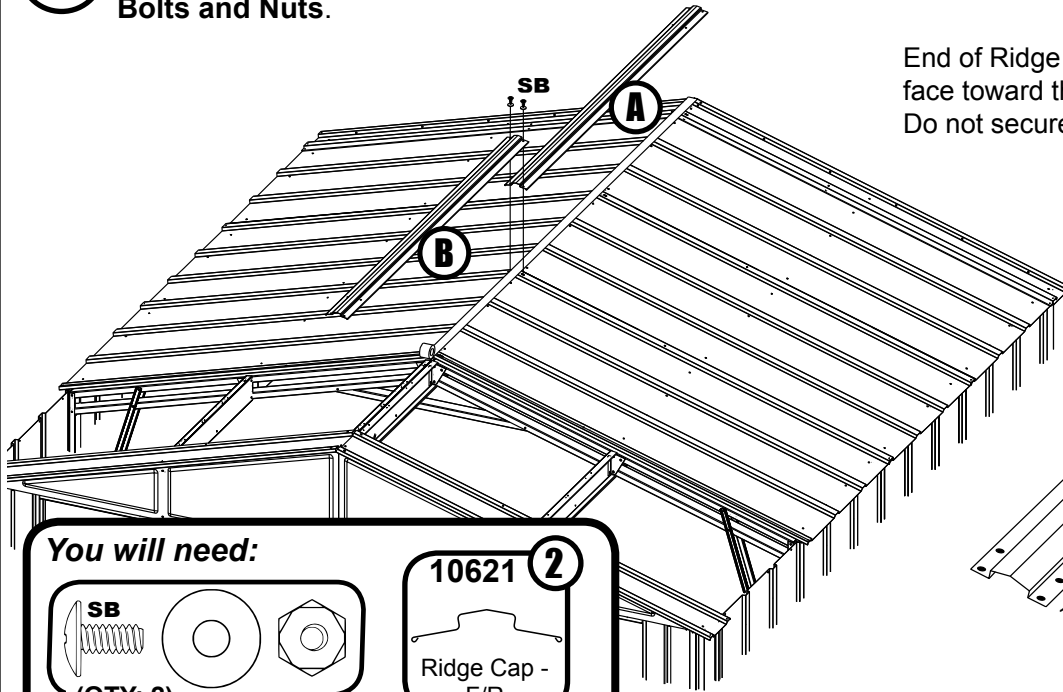

End of Ridge Cap with four holes must face toward the outside of the building. Do not secure at this time.

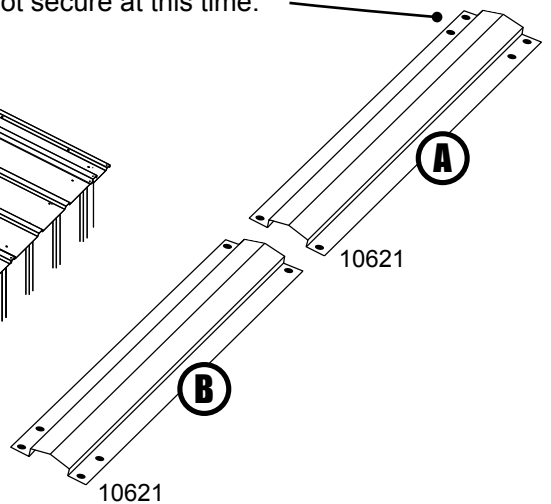

**You will need:**

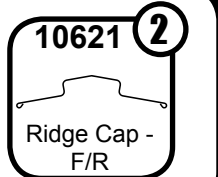
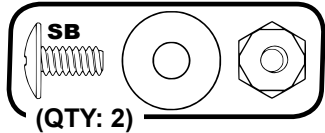

**For 10'x15' (3.0 m x 4.6 m) or larger.**

- 5** Overlap one **Front and Rear Ridge Cap** and one **Mid Ridge Cap** as shown and secure with two **Small Bolts and Nuts**.

End of Ridge Cap with four holes must face toward the outside of the building. Do not secure at this time.

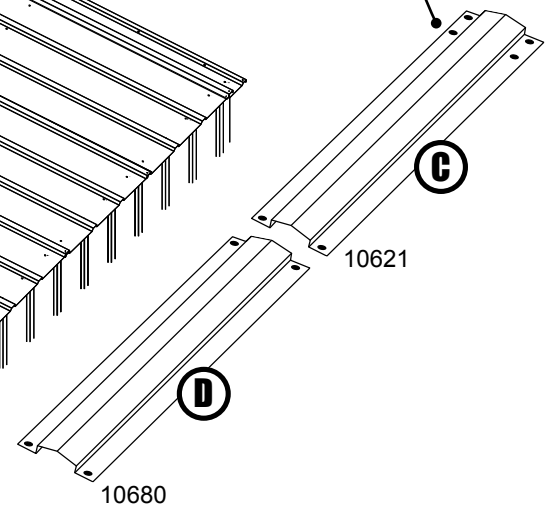
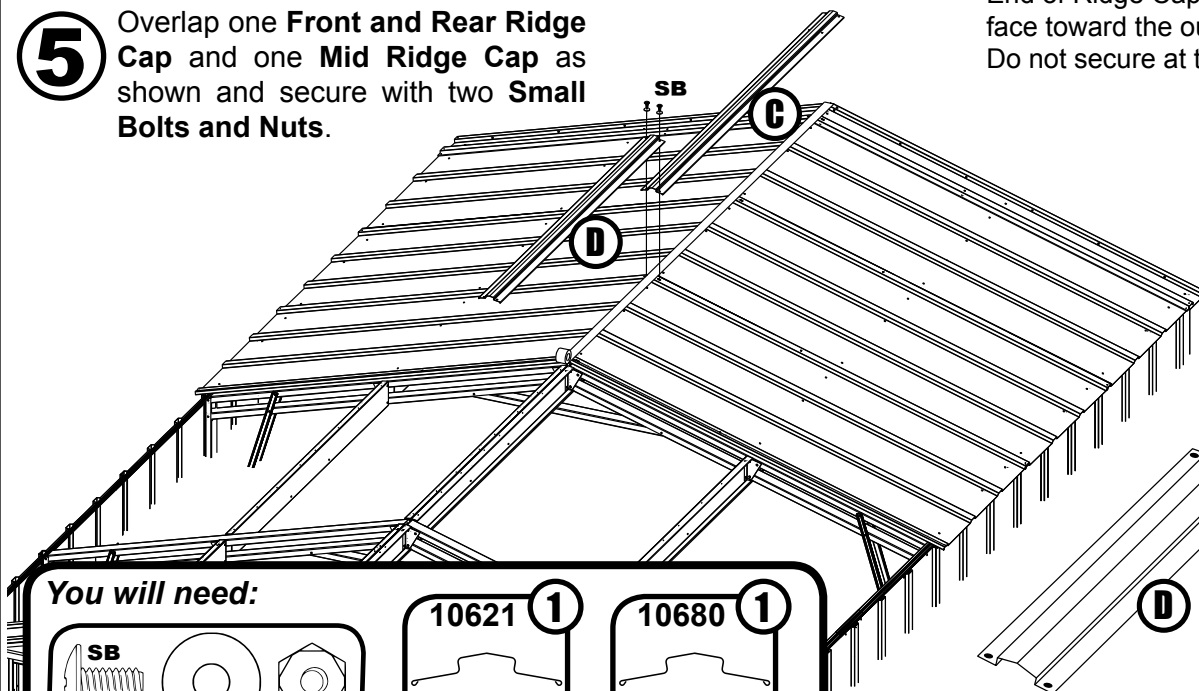

**You will need:**

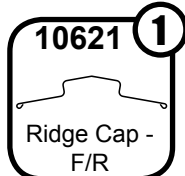
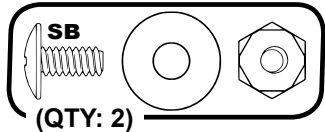

# Step 11: Continued for Extension Modules

You will need for this page:

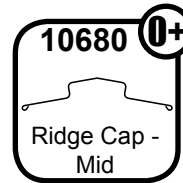
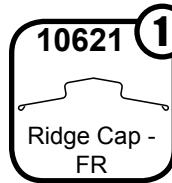
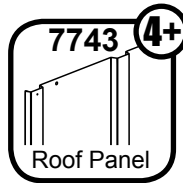
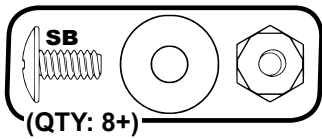
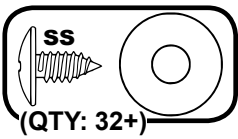

Continue to apply Weather Stripping.

**NOTE** If you are erecting a 10'x10' (3.0 m x 3.1 m) building, skip this page and move on to page 36.

**6** Install two more **Roof Panels**. Continue to apply **Weather Stripping Tape** as you go.

**7** Where the last two **Panels** overlap over the **Truss**, insert two **Small Bolts and Nuts** and seal with two 2" (5,1 cm) strips of **Tape**.

**8** Install two more **Roof Panels**.

**9** Overlap the last **Ridge Cap** installed with the next **Ridge Cap** and secure with two **Small Bolts and Nuts** as shown.

**10** Repeat the steps on this page until you have only two **Roof Panels** remaining. Before moving on to the next page, all **Ridge Caps** should be in position, but the ends of the **Front and Rear Ridge Caps** at the front and rear of the building should not be secured yet.

**NOTE** DO NOT fully tighten Ridge Cap Bolts until you have both Ridge Cap Bolts in place. This will ease assembly. Bolts must be fully tightened before moving on to the next page.

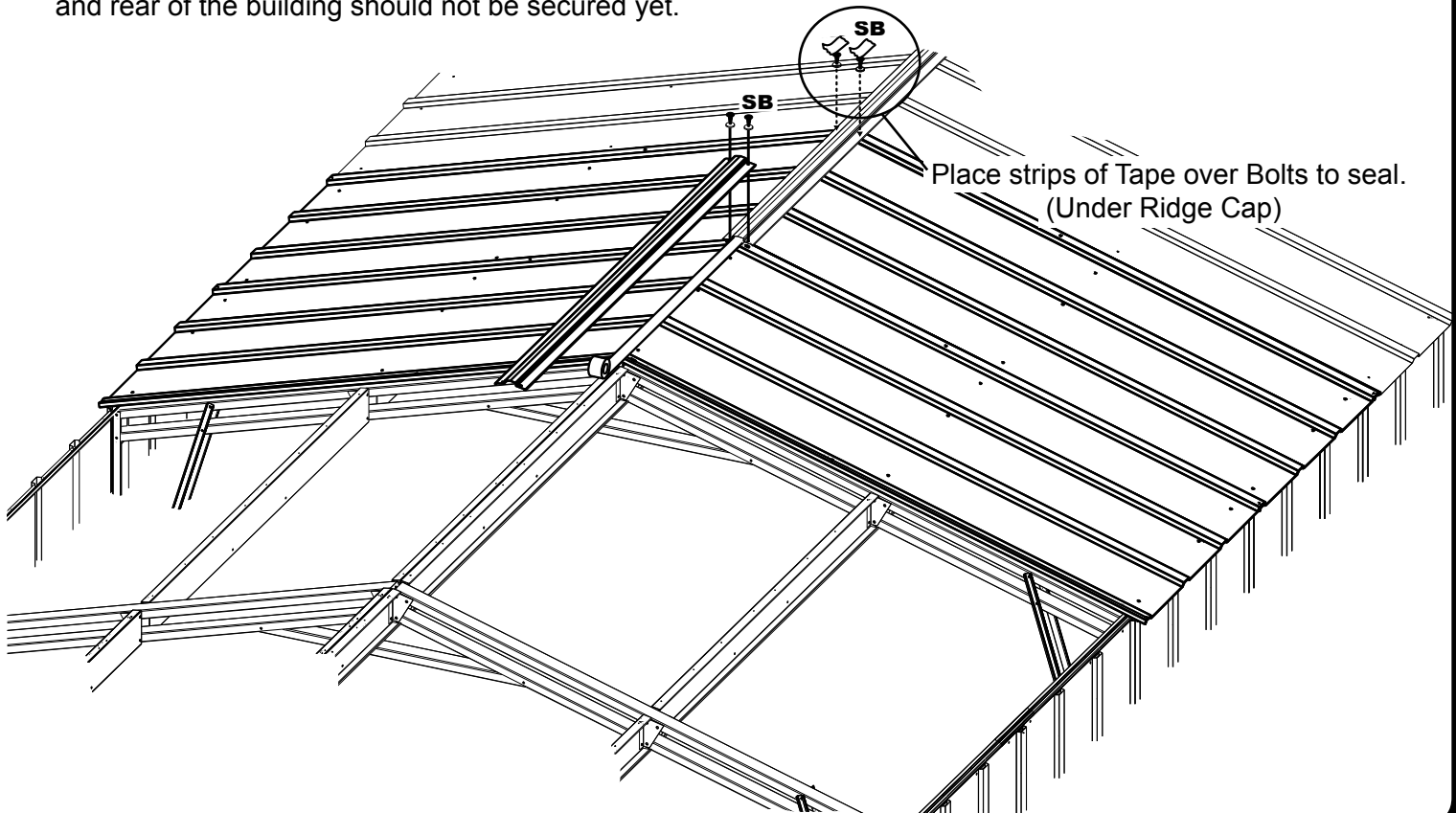

# Step 11: Continued

You will need for this page:

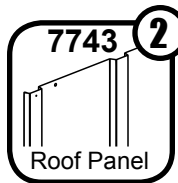
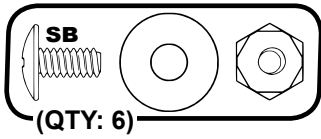
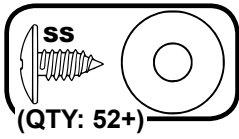

• Bolts under Ridge Cap pass thru slots where the End Roof Panel is overlapped by the Panel next to it (labeled rib 5 below).

Continue to apply Weather Stripping.

**11** At this point there should be only two **Roof Panels** remaining. Install last two **Roof Panels**. Because the last **Ridge Cap** is already in place and has been secured at one end, you may need to move the **Ridge Cap** slightly to secure the last two **Panels** to the **Main Roof Beams**.

**12** Finish weather stripping the roof under the **Ridge Cap** and cut the **Tape** just past the end of the roof. Fold end of **Tape** under roof edge.

**13** With all **Roof Panels** in place, secure the bottom of **Roof Panels** to the **Side Wall Angles** with **Small Screws** on both sides of the building.

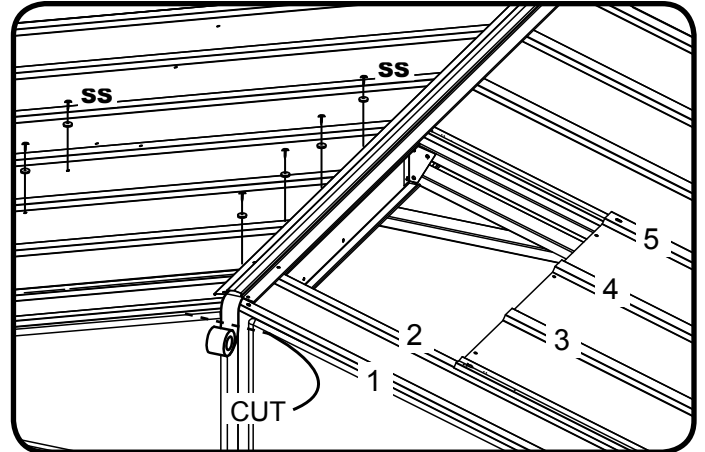

**NOTE** DO NOT fully tighten Ridge Cap Bolts until you have both Ridge Cap Bolts in place. This will ease assembly. Bolts must be fully tightened before moving on to the next page.

DO NOT secure ends of Ridge Caps until Peak Caps are in place.

Alternate sides while securing roof panels.

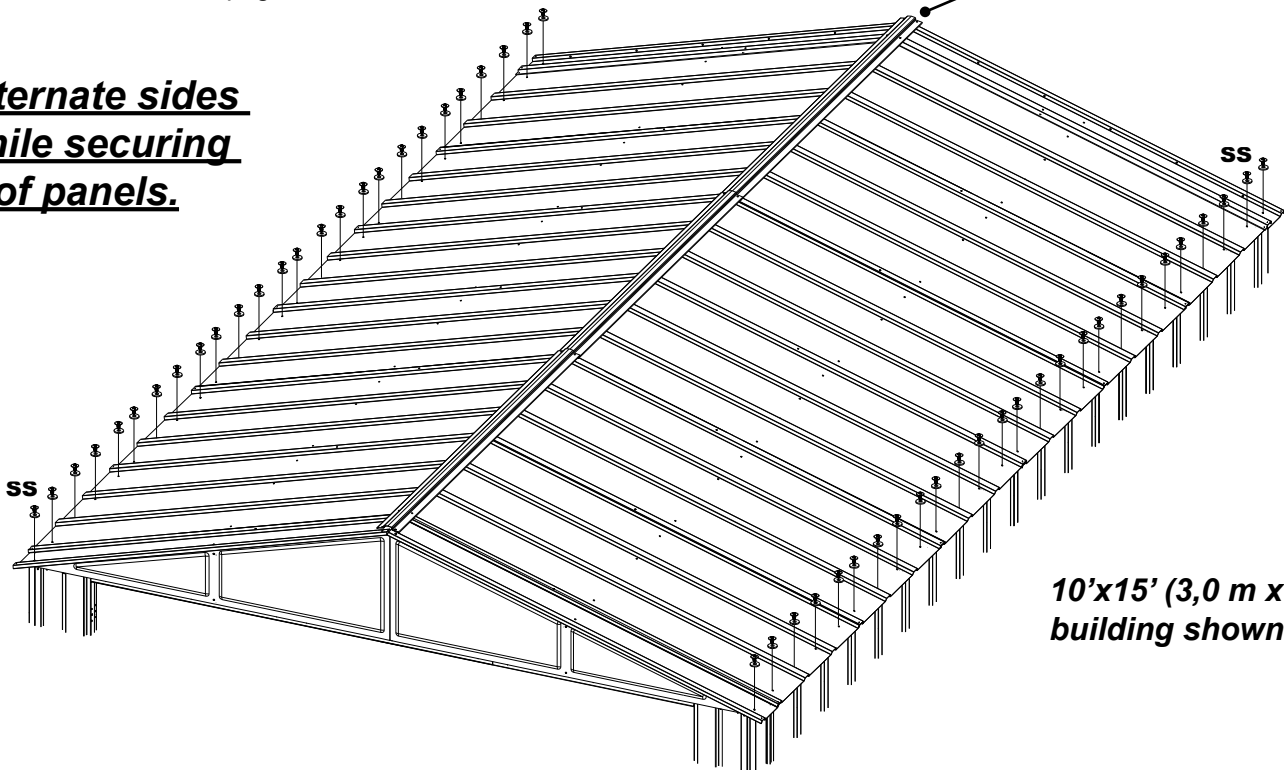

10'x15' (3,0 m x 4,6 m) building shown.

# Step 12: Roof Trim

You will need for this page:

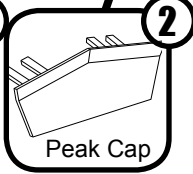
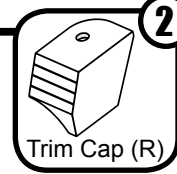
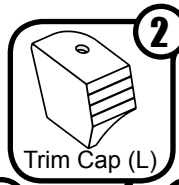
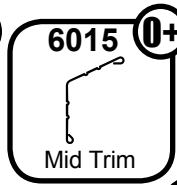
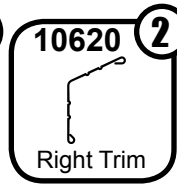
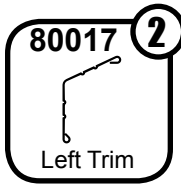
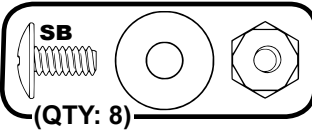
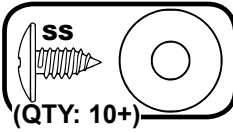
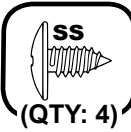

**1** Slide **Peak Cap** legs under **Ridge Cap** and secure **Ridge Cap** ends with four **Small Bolts and Nuts** on each end as shown.

**2** Position **Left and Right Roof Trim** as shown below and secure with **Small Screws**. Do not fasten the last **Screw** on each end. Pay close attention to where the **Left and Right Roof Trim** pieces are located.

**3** If you are erecting a 10'x15' (3,0 m x 4,6 m) or larger building, install **Mid Roof Trim** along the remainder of the roof edge. **Roof Trim** overlaps as shown to the right.

**4** Position the **Roof Trim Caps** as shown below and secure with a **Small Screw**. Using your thumb and index finger, overbend the bottom flange of the **Side Roof Trim** at the corner inward enough so the right and left **Roof Trim Caps** fit onto right and left corners.

Roof Trim Caps are positioned as shown.

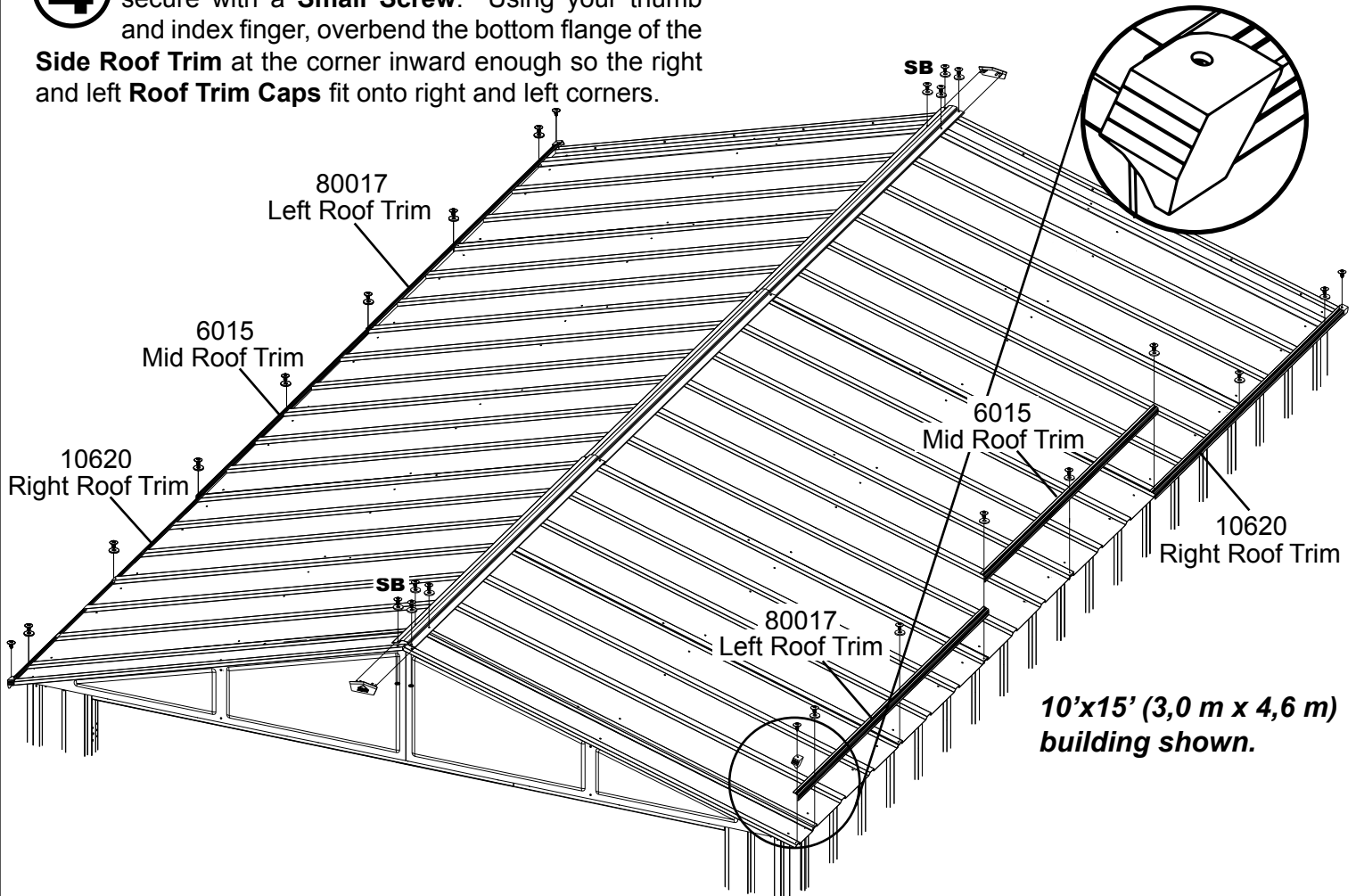

**10'x15' (3,0 m x 4,6 m) building shown.**

# Step 13: Door Assembly

You will need for this page:

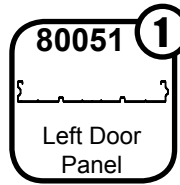
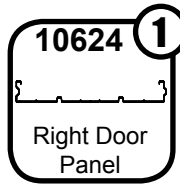
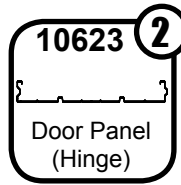
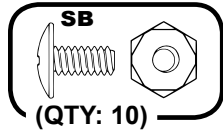

**NOTE** If you purchased a Door Kit, repeat Door Assembly process for rear of building.

Refer to page 11 for Door assembly overview.

**1** Position Door Panels as shown and secure using Small Bolts and Nuts. **NOTE: Door Panels** in the image below are shown pictured from the inside of the building. Pay close attention to how Panels are positioned. Below are end views showing Panel position.

**NOTE** The best way to assemble the Doors is on a flat, elevated surface such as a table or workbench.

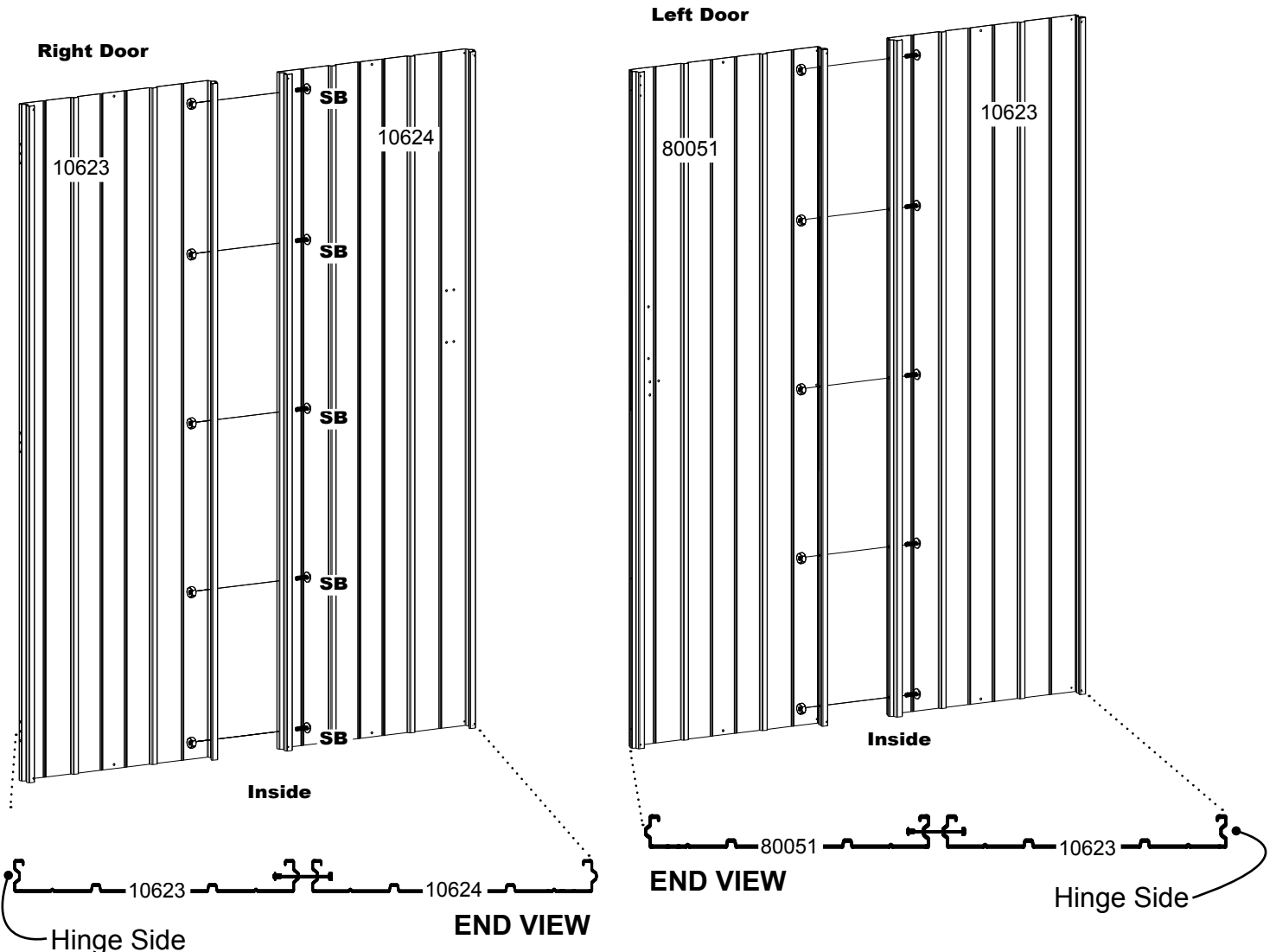

# Step 13: Continued

You will need for this page:

[ NO HARDWARE NEEDED  
FOR THIS STEP ]

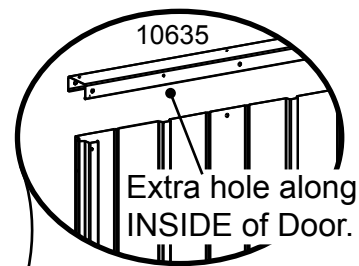
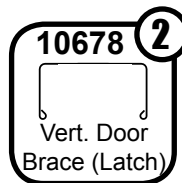
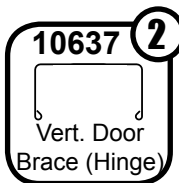
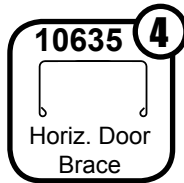

**2** Position **Horizontal Door Braces**, and **Vertical Door Brace (Hinge)** and **Vertical Door Brace (Latch)** as shown.

**NOTE: Doors** in the image below are shown pictured from the inside of the building. Pay close attention to how parts are positioned. Make sure hinge holes in the **Vertical Door Brace (Hinge)** line up with hinge holes in **Door Panel (Hinge)**.

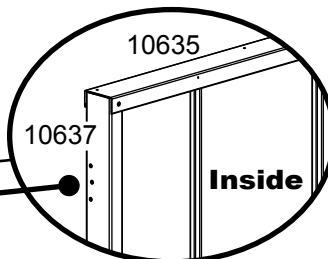
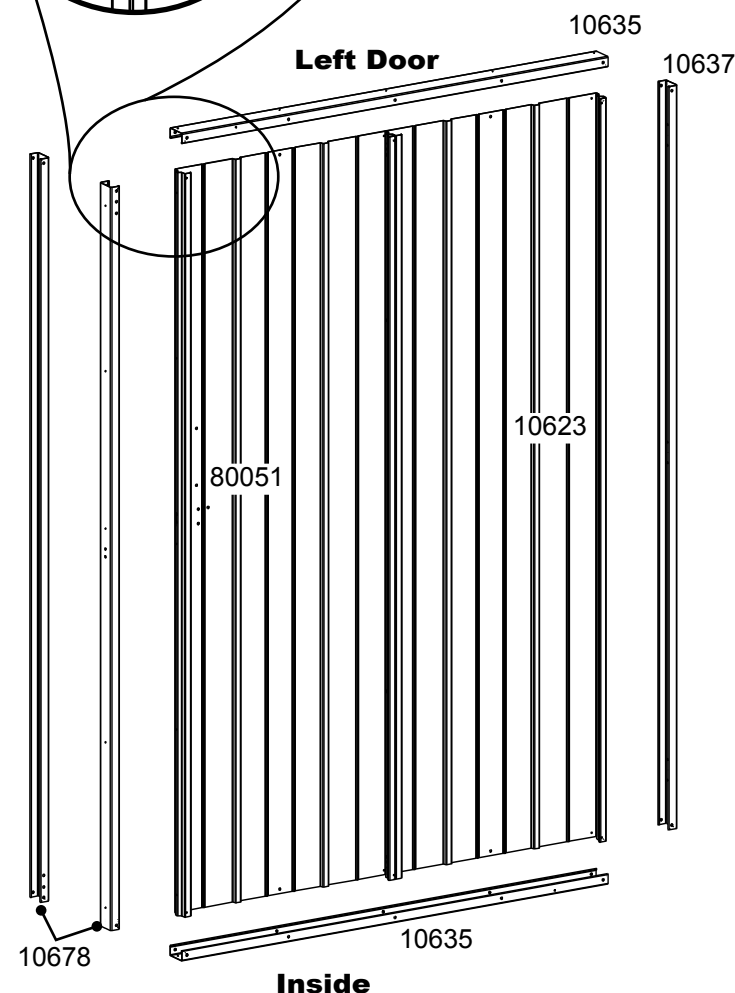
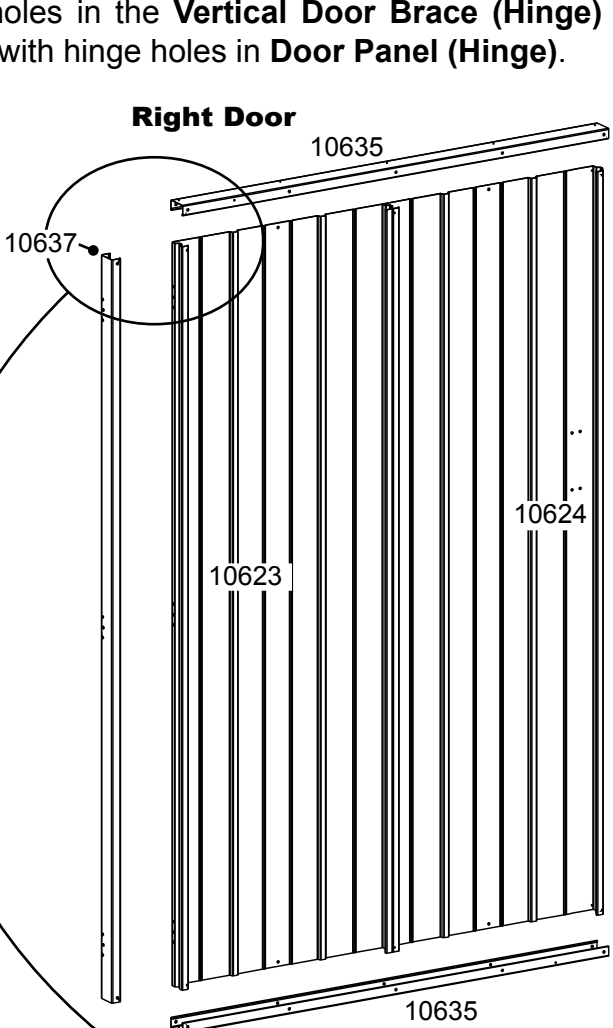
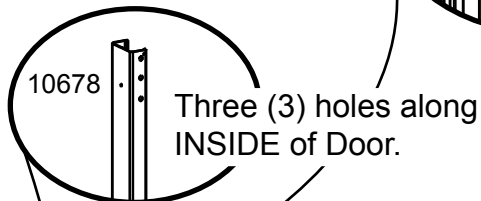

Holes in Door Brace must line up with holes in Door Panel.

# Step 13: Continued

You will need for this page:

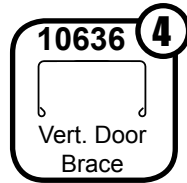
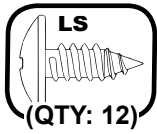

Open ends of Vertical Door Braces must face edge of Doors.



**3** Slide **Vertical Door Braces** into position with ends inside **Horizontal Door Braces**. Double check that the open ends of the **Vertical Door Braces** face the edges of the **Door** (see image to right) and secure with **Large Screws** in each **Door**. **NOTE: Doors** are shown pictured from inside building.

**Right Door**

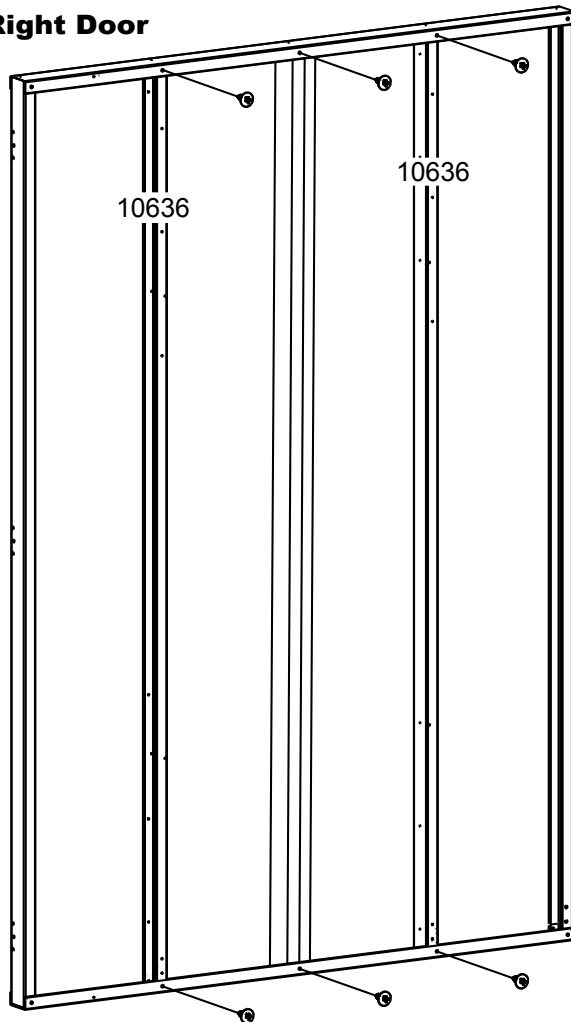

**Left Door**

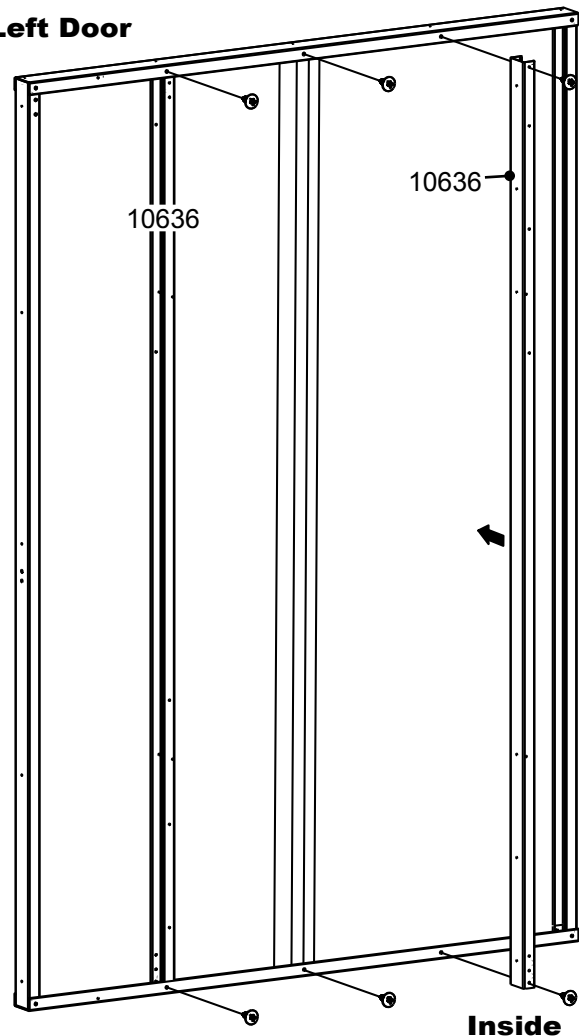



# Step 13: Continued

You will need for this page:

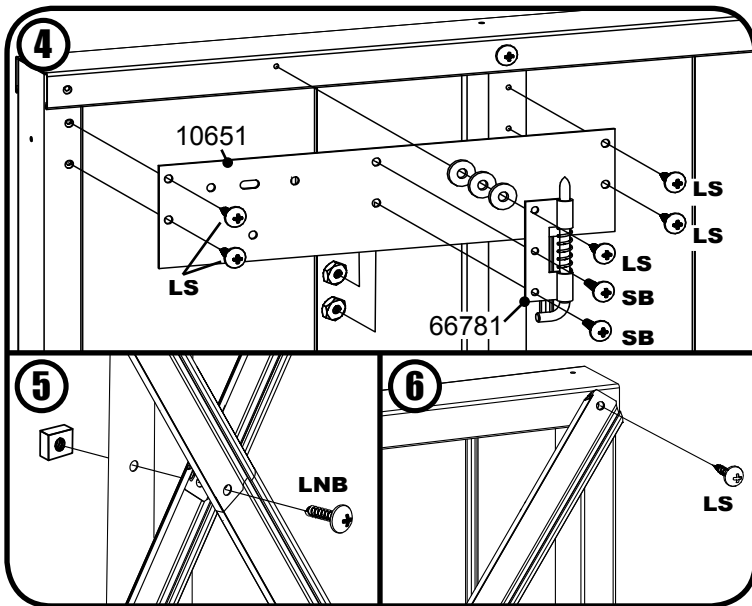
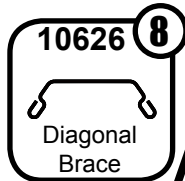
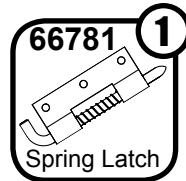
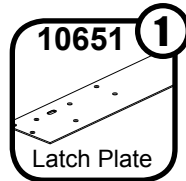
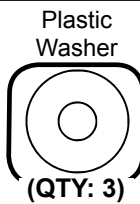
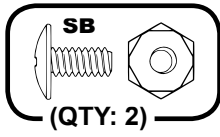
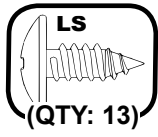
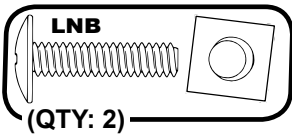

**4** Position parts as shown and secure to upper inside corner of left Door with Large Screws. Spring Latch attaches to Latch Plate using Small Bolts and Nuts. Place three (3) Plastic Washers behind top hole of Spring Latch as shown; this will help alignment.

**5** Where Braces overlap, insert a Long Bolt through all Braces and Door Panel and secure with a Nut.

**6** Secure Diagonal Braces to Doors in all corners with Large Screws.

Left Door

Right Door

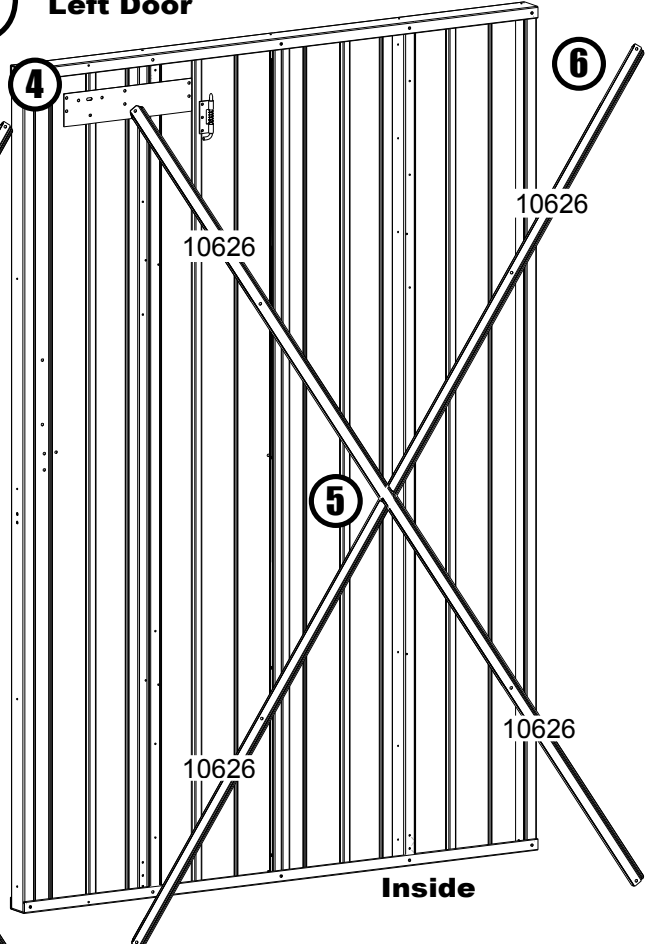
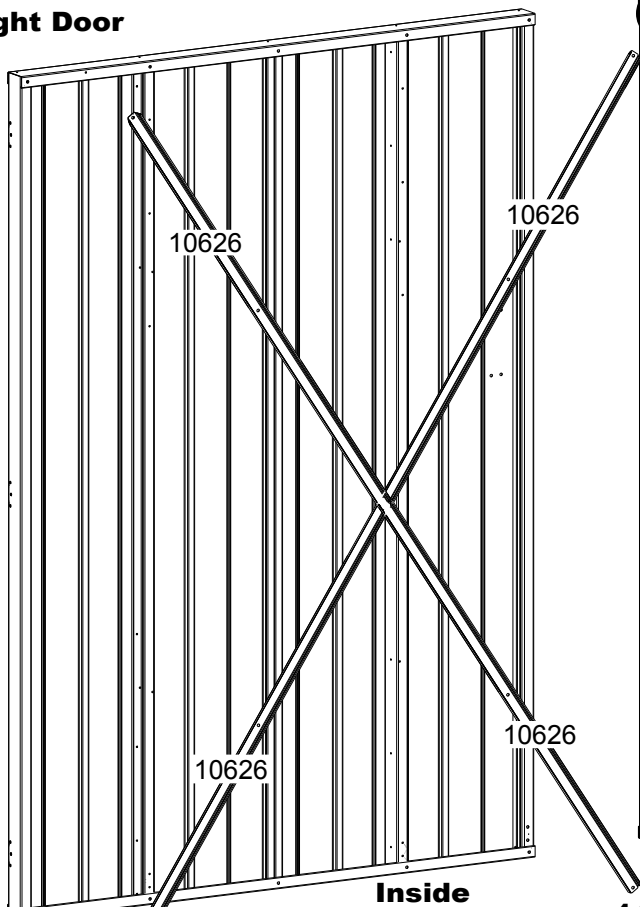

# Step 13: Continued

You will need for this page:

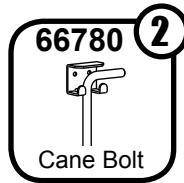
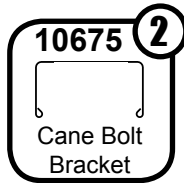
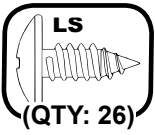

**NOTE** The Cane Bolt, Door Handles and Slide Bolt are pre-packaged with their own hardware. This hardware is not used when assembling the building. Instead, use the hardware indicated in each step.

**7** Secure all **Diagonal Braces** to the **Vertical Door Braces** with **Large Screws** as shown. Next, position the **Cane Bolt Bracket** back-to-back against the **Vertical Door Brace** closest to the center of one (1) **Door** as shown. Slide the **Cane Bolt Bracket** to the bottom of the **Door** and secure with three (3) **Large Screws**. Repeat for other **Door**.

**8** Align the **Cane Bolt** with the holes in the **Cane Bolt Bracket** and **Vertical Door Brace** and secure with six (6) **Large Screws** as shown. Repeat for other **Door**.

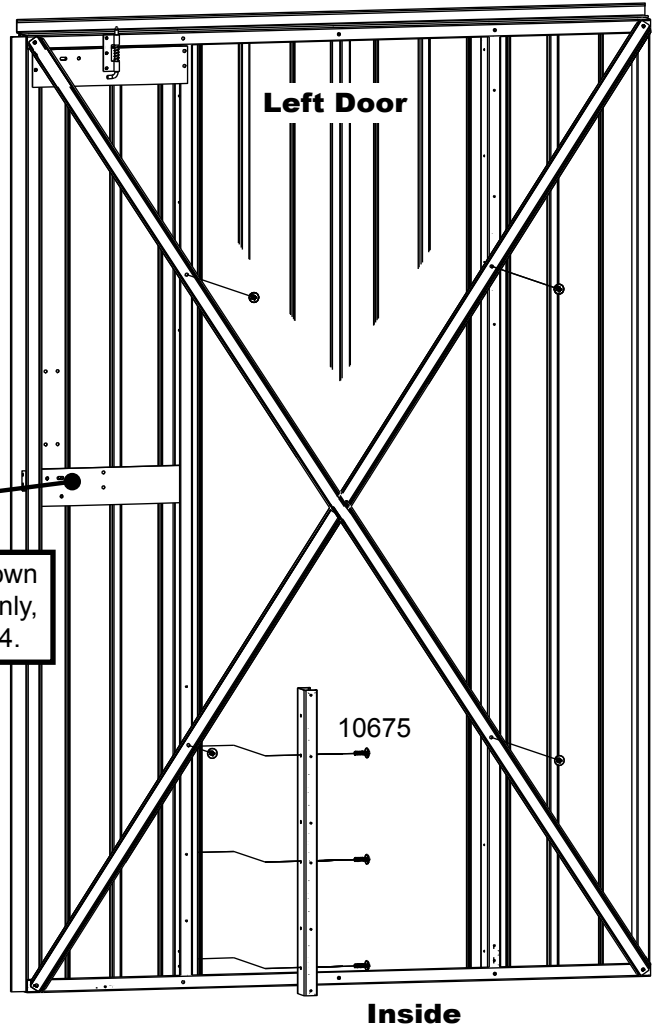
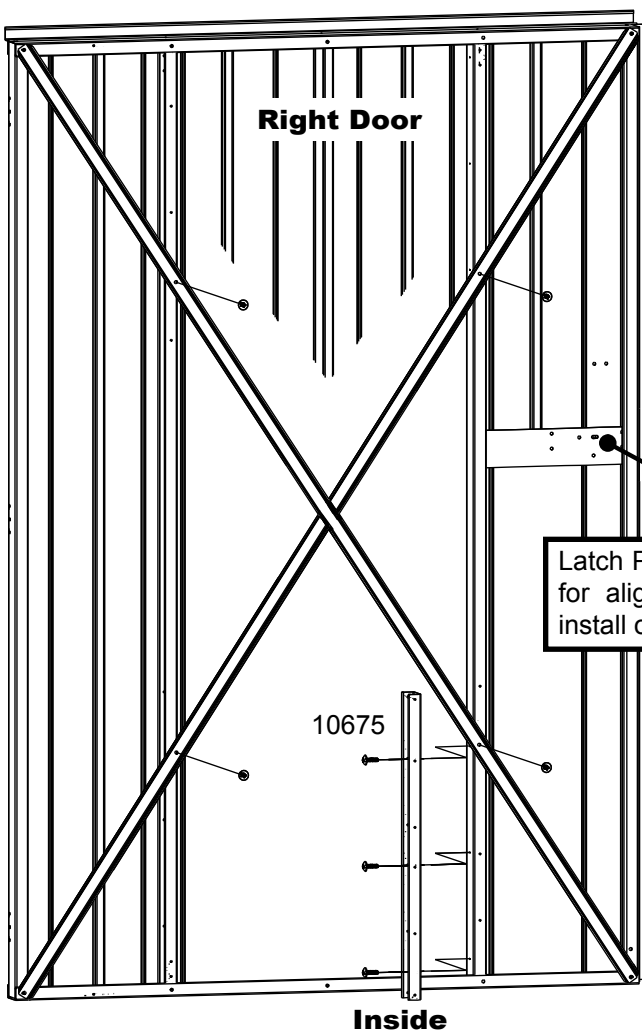
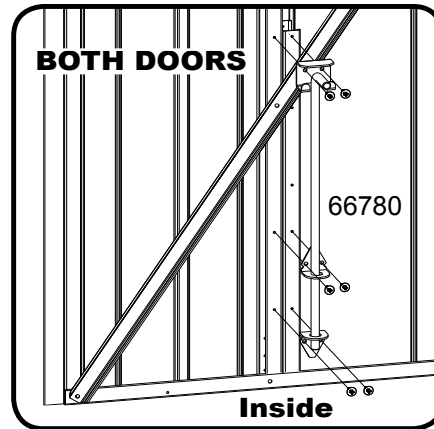

# Step 13: Continued

You will need for this page:

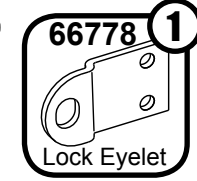
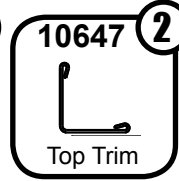
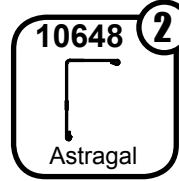
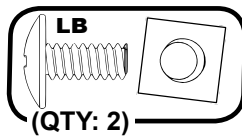
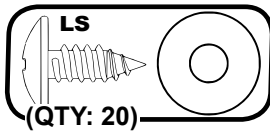
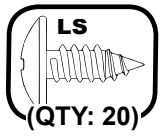

**9** Secure the **Horizontal Door Brace** to the **Door** with **Large Screws**. Position **Door Trim** and **Astragals** as shown and secure with **Large Screws**. **Lock Eyelet** slides through **Astragal** on **Right Door** and is secured with two (2) **Large Bolts** and **Square Nuts**. Pay close attention to the position of each part.

**NOTE** If holes do not align, insert Screw at an angle.

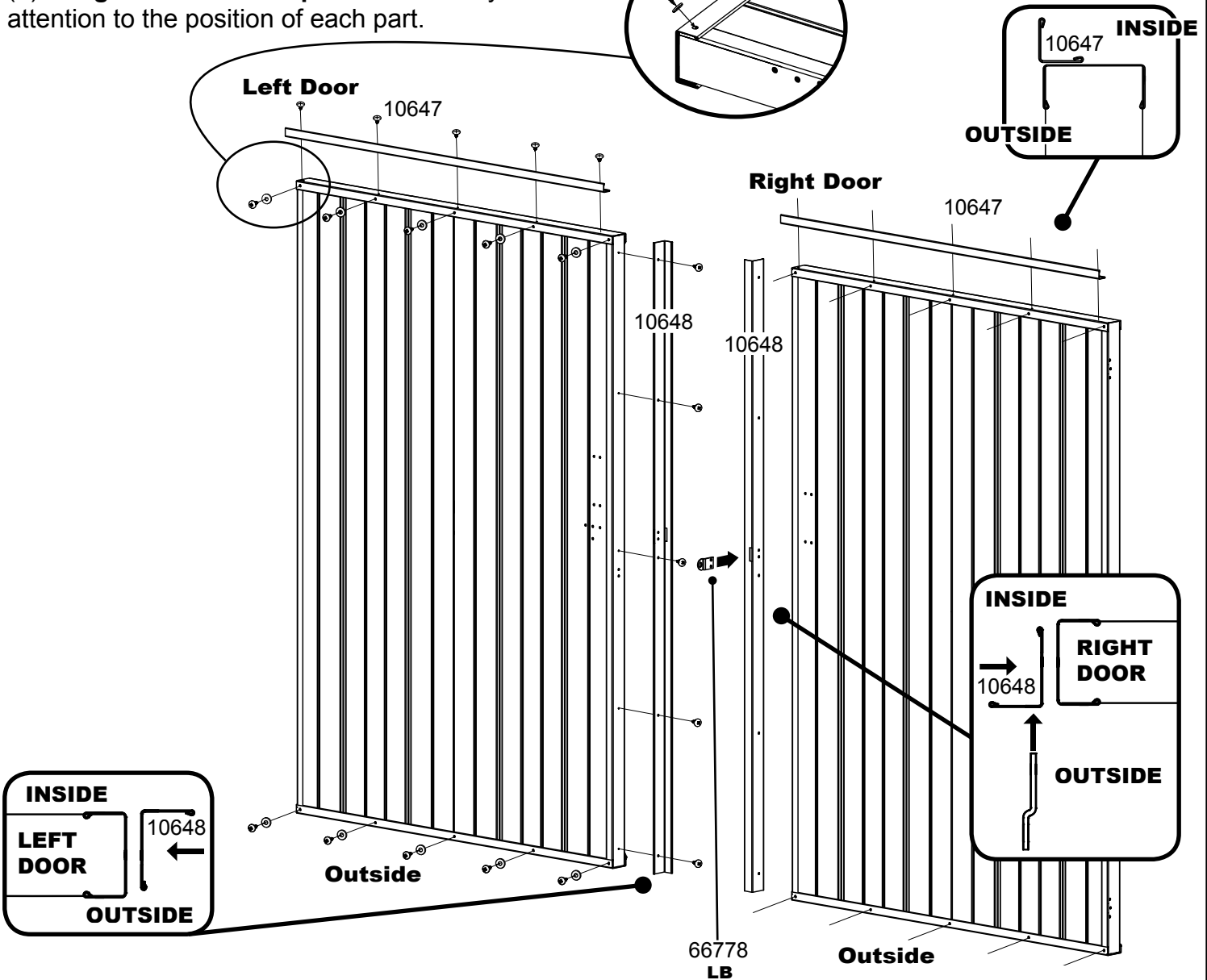
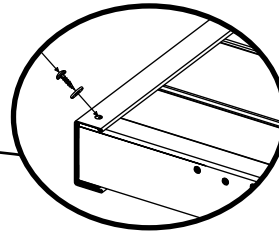

# Step 13: Continued

You will need for this page:

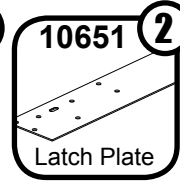
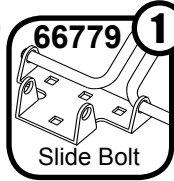
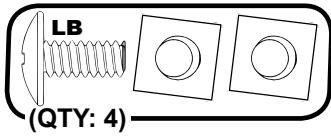
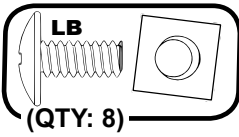

**10** Slide **Latch Plate** into position on the **Left Door**. Next, position the **Slide Bolt** on the face of the **Door** and secure with **Large Bolts** and two (2) **Square Nuts** on each **Bolt**. Position the **Door Handle** on the face of the **Left Door** and secure with **Large Bolts** and **Square Nuts**. This completes the **Left Door** assembly.

**NOTE** Do not use hardware supplied with Door Handle and Slide Bolt. Instead, use the hardware indicated in this step.

**11** Slide **Latch Plate** into position on the **Right Door**. Next, position the **Door Handle** on the face of the **Door** and secure with **Large Bolts** and **Square Nuts**. This completes the **Right Door** assembly.

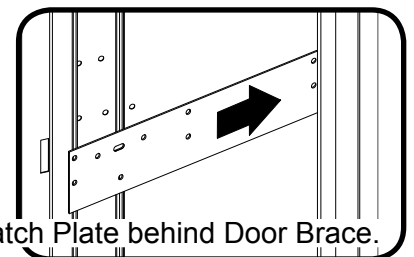
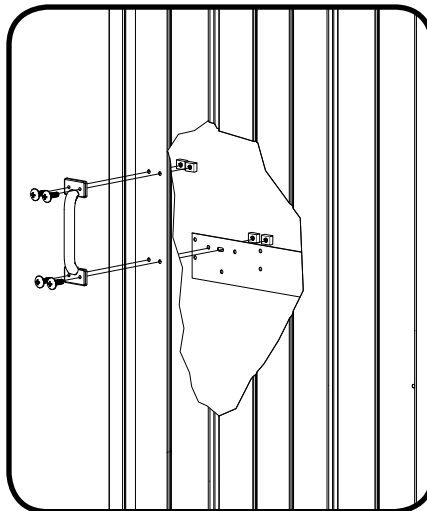
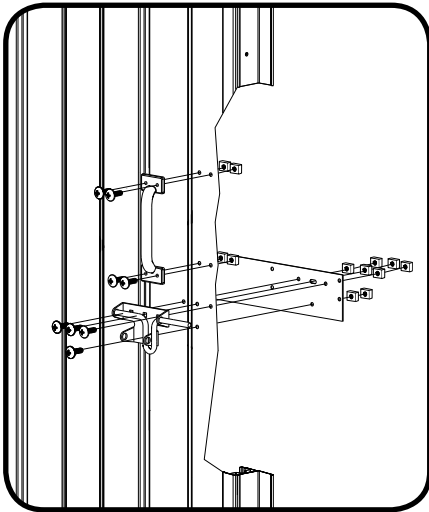
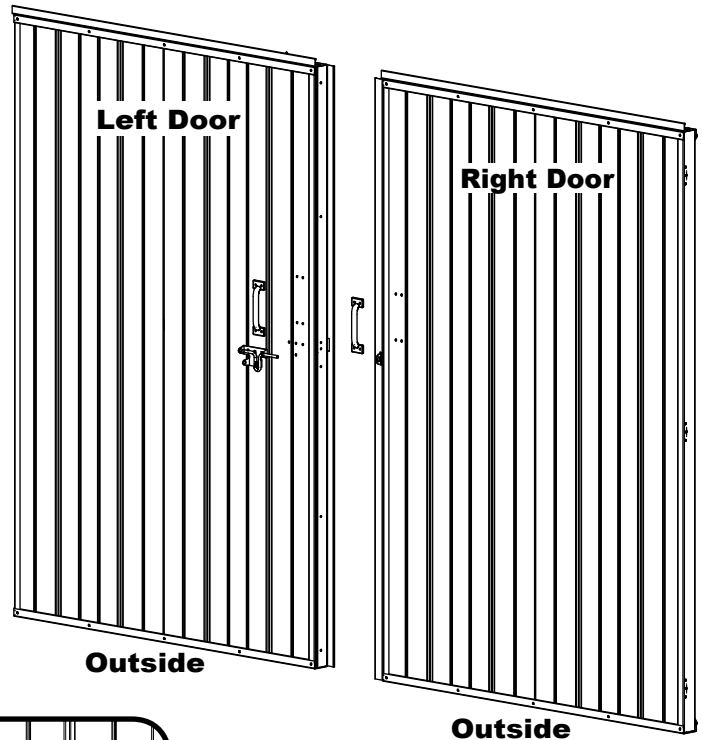

Slide end of Latch Plate behind Door Brace.

# Step 13: Continued

**Slide Bolt may need adjustment to align properly.**

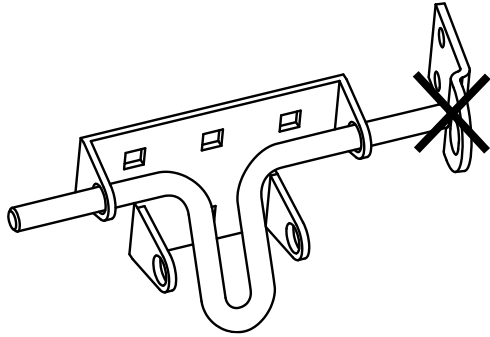

If Slide Bolt does not align properly, you may need to insert plastic washers between the door and the Slide Bolt to ensure proper fit. Adjust number of plastic washers until desired fit is reached.

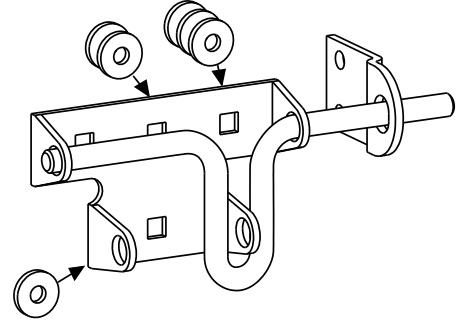

**You will need:**

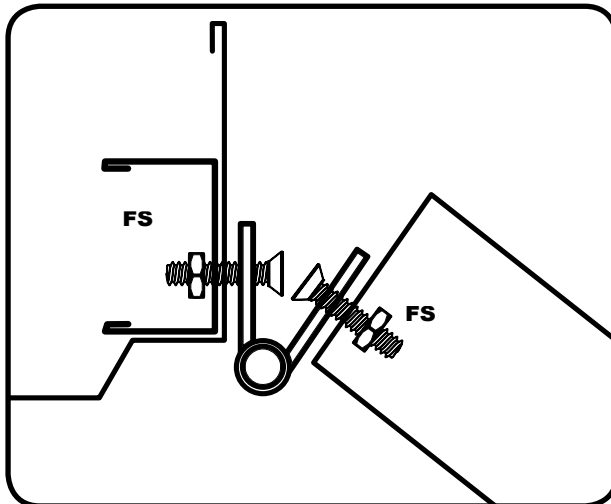
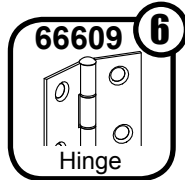
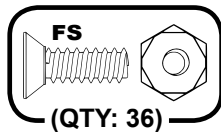

## **Hanging the Doors:**

After the Doors have been assembled, install hinges on one (1) Door using Flathead Screws and Nuts. Use the image to the left as a guide to proper hinge position. Next, position one (1) Door in the doorway of the building and secure the hinges, from top to bottom, to the Door Jamb, *but do NOT fully tighten*. With all hinges in place, hold the Door in alignment and slowly tighten the Bolts on the Door Jamb side of the hinge. Repeat to hang the other Door.

Swing the Doors carefully to check alignment. If Doors are misaligned, slightly loosen the Bolts on the Door Jamb side of the hinge and realign the Door. Fully tighten when done.

**IMPORTANT:** Once the building is fully assembled, measure across the door opening and check that it is 98 1/4" (249,6 cm). If it is not, move the front walls in or out slightly to match this dimension. This must be done **BEFORE** anchoring.

# ANCHORING OPTIONS...

## IMPORTANT:

- *If you have swing doors, they must hang and swing level before anchoring building.*
- *Anchor your building at this time. See below for details on anchoring.*
- *After anchoring, drill a 5/8" (1,6 cm) hole at least 2" (5,1 cm) into your base to receive the left-side Cane Bolt and hold the Door (left side only) closed.*
- *Please take a moment to ensure that the building is installed in accordance with these instructions and with all applicable regulations.*

## Anchoring Down The Building

The entire floor frame **MUST** be securely anchored once the building is erected.

Below are recommended ways of anchoring.

### **Arrow Anchoring Kit:** (Model No. AK4 or 60298)

Recommended for use with **any** suggested base.

**Contains:** 4 Anchors with Cable, Clamps and installation instructions.

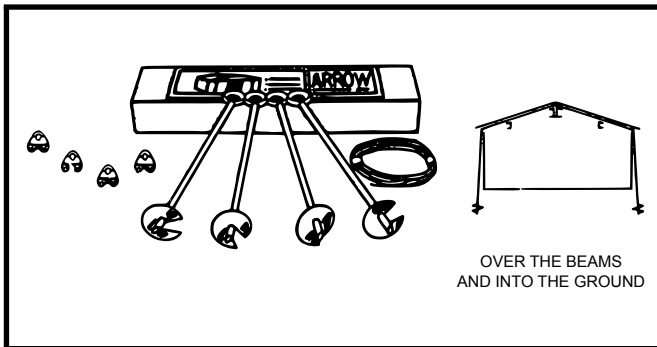

### **Anchoring into Wood/Post:**

Use 1/4" (6 mm) Wood Screws. There are 1/4" (6 mm) dia. holes provided in the frames for proper anchoring.

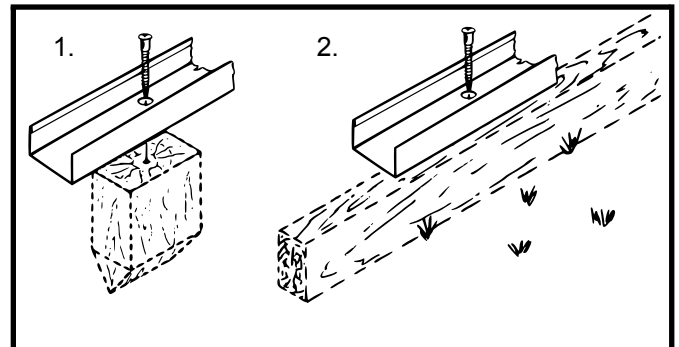

### **Arrow Anchoring Kit:** (Model No. AK100 or 68383)

Recommended for use with the **concrete** base.

**Contains:** Corner gussets, perimeter clips, hardware, 1/4" masonry drill bit and installation instructions.

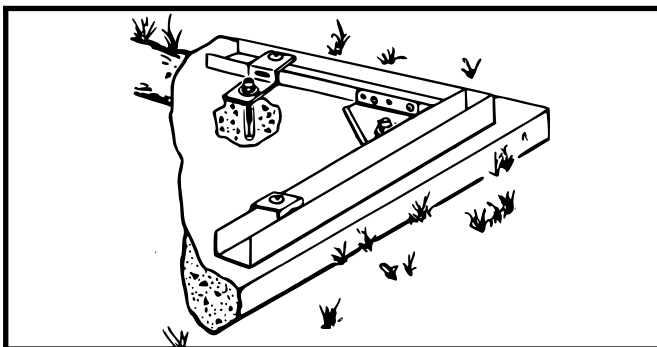

### **Anchoring into Concrete:**

1. For poured concrete slab or footing or patio blocks: Use 1/4" x 2" (6 mm x 51 mm) Lag Screws.
2. For Anchor Post of Concrete poured after building is erected: Use 1/4" x 6" (6 mm x 152 mm) Lag Screws.

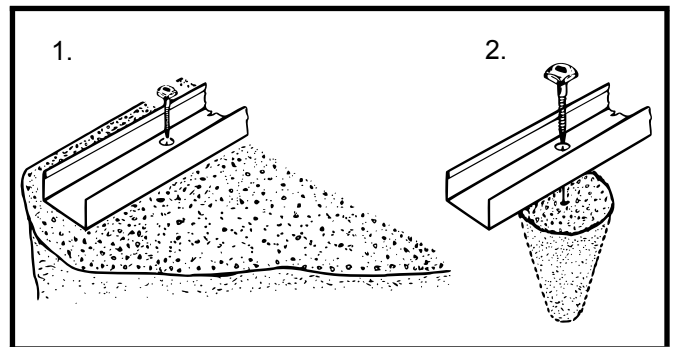

# CARE & MAINTENANCE...

## ***Exterior Care:***

For a long lasting finish, clean and wax the exterior surface. We recommend washing with a mild soap solution. DO NOT use power washing to clean your shed. Using a spray automotive type wax periodically on the exterior is highly recommended if you are in a high humidity or coastal climate region.

Combustibles and corrosives must be stored in air tight containers designed for chemical and/or combustible storage. Corrosive chemicals such as fertilizers, pesticides and herbicides should be cleaned off the interior and exterior surfaces immediately. Rust caused by chemical damage is not covered by the warranty.

## **DO NOT STORE POOL CHEMICALS IN YOUR SHED - THIS VOIDS YOUR WARRANTY**

Rust protection precautions may help to stop rust from developing, or stop it quickly as soon as it appears.

- Avoid nicking or scraping the coating surface, inside and out.
- Keep roof, base perimeter and door tracks free of debris and leaves which may accumulate and retain moisture. These can do double damage since they give off acid as they decay.
- Touch up scrapes or nicks and any area of visible rust as soon as possible. Make sure the surface is free of moisture, oils, dirt or grime and then apply an even film of high quality touch-up paint.
- Various paint manufacturers provide products for rust treatment and coverage. If surface rust does appear on your shed we recommend treating those areas as soon as possible, following the paint supplier of your choice instructions.
- Our customer service department can provide the paint tinting formula for matching the color of your shed. We also have touch-up paint available for repairing small nicks and scratches.

## ***Roof:***

Keep the roof clear of leaves and snow. Heavy amounts of snow on the roof can damage the building making it unsafe to enter. In snow country, Roof Strengthening Kits are available for most Arrow Buildings for added protection against heavy snow accumulation.

## ***Doors:***

For sliding doors, always keep door tracks clear of dirt and other debris that prevents them from sliding easily. Lubricate door track annually with furniture polish or silicone spray. Keep doors closed and locked to prevent wind damage.

## ***Fasteners:***

Use all washers supplied to protect against weather infiltration and to protect the metal from being scratched by the screws. Regularly check screws, bolts, nuts, etc., and retighten as necessary.

## ***General:***

- A plastic sheet (vapor barrier) placed under the entire floor area may reduce condensation.
- Wash off inked part numbers on coated panels with soap and water.
- Silicone caulking may be used for watertight seals throughout the building.

Please note, Manufacturer cannot be held responsible for any consequences due to buildings that are not installed per these instructions, or for damage due to weather conditions or acts of God.

**Keep these assembly instructions and owner's manual for future reference.**

# ARROW ACCESSORIES...

## ANCHOR KITS

### Model No. AK4

Anchor Kit contains heavy-duty steel augers, 60' (18 m) of steel cable and 4 cable clamps. No digging or concrete pouring, just insert cable under roof, over roof beams, into augers and twist augers into the ground. For buildings larger than 10'x9' (3,0 m x 2,6 m), use 2 kits.

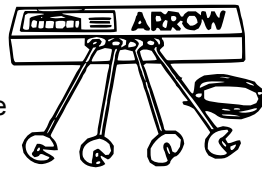

### Model No. AK100

New concrete anchor system permits anchoring any size Arrow building directly to a concrete slab. Each kit contains heavy-duty, hot-dipped galvanized steel corner gussets and perimeter clips which fit over the floor frame and lag bolt into a concrete slab. Full assembly instructions and a 1/4" masonry drill bit are included.

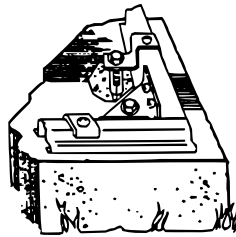

## TOOL HANGING RACK

### Model No. TH100

The perfect tool organizer. Twin 25 1/2" (64,8 cm) steel channels plus five heavy-duty snap-in hangers and a small tool holder for screwdrivers, pliers, etc. Holders slide along channel for fully adjustable spacing. Great for garage, basement, or the back of any door. Fits all Arrow storage buildings.

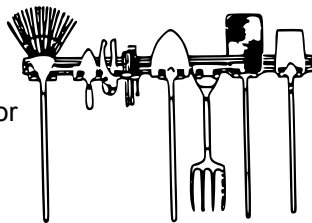

## ATTIC KIT / WORKBENCH KIT

### Model No. AT101

Heavy-duty galvanized steel bars that fit all 10' (3,0 m) wide Arrow buildings. They install quickly and easily to help organize space and create more useable space as an attic or workbench. Will hold up to 250 lbs. (113 kg) evenly distributed.

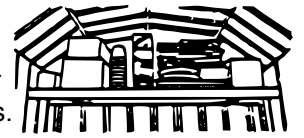

Some drilling required to fit buildings without mid-wall bracing.

## SHELF UNITS

Heavy-duty, galvanized steel shelf units help organize storage space. They easily mount on the wall or sit on the floor. Fits all Arrow buildings.\*

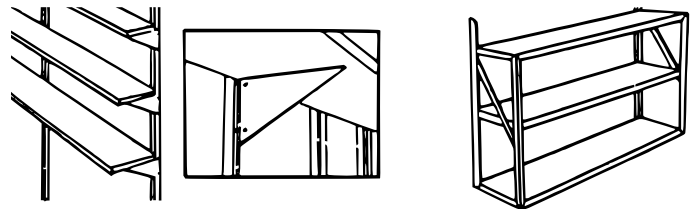

### Model No. SS404

- Makes 8" to 12" (20,3-30,5 cm) wide shelves in any length.
  - Brackets, braces, hardware included.
- Lumber is not included.

### Model No. SS900-A

- Grey color
- 3 shelves
- Holds up to 85 lbs. (38 kg) (even weight distribution)

\* Some drilling required to fit buildings without mid-wall bracing.

## SPECIAL NOTICE ON DELIVERY:

If your accessory is shipped via truck line a day time phone number is required to arrange delivery. If no one is available to sign for the delivery, you may be subject to a re-delivery charge assessed by the carrier.

## HOW TO ORDER

We recommend that you purchase accessory items from your local storage building dealer whenever possible; however, because the full line of accessories is not always available from all dealers, Arrow is offering them to you on a direct basis.