



ALIENGEAR
HOLSTERS.

SHAPESHIFT

MODULAR HOLSTER SYSTEM



IWB



APPENDIX



OWB PADDLE



OWB SLIDE

CORE CARRY PACK

USER MANUAL

CORE CARRY PACK

With its revolutionary design, your ShapeShift is prepared to meet the demands of your carry lifestyle. This user manual includes comprehensive steps to shift your holster into four distinct carry positions. It also includes instructions on mounting your holster to virtually any surface.



IWB



APPENDIX



OWB PADDLE



OWB SLIDE



Thank you for choosing our American company.



Contents

Shift Shell.....	3, 4
Retention.....	5
IWB Holster	6
▪ Assembly.....	7
▪ How to Wear/ Adjust.....	8
Appendix Carry Holster	9
▪ Assembly.....	10
▪ How to Wear	11
OWB Slide Holster	12
▪ Assembly.....	13
▪ How to Wear	14
OWB Paddle Holster	15
▪ Assembly.....	16
▪ How to Wear/Adjust.....	17
Holster Mount	18
▪ Installation.....	19, 20
Upcoming Products	21

Configure Your Shift Shell

Your Shift Shell can be worn in a half or full shell configuration depending on your chosen carry position. The half shell configuration is designed for concealed carry, which includes the IWB, OWB Slide and Appendix Carry positions. The full shell configuration is made for carrying with the OWB Paddle.

Learn how to shift your shells below.

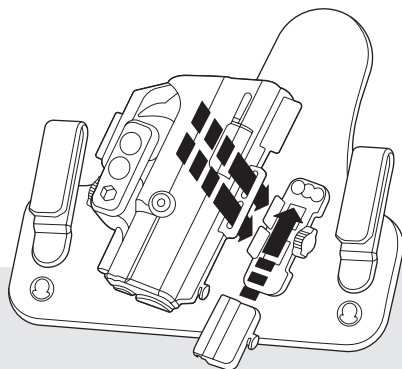

Half Shell Configuration

Appendix, IWB, OWB Slide

- 1 Untwist the twist locks from the top and bottom of your Shift Shell, then slide the two shells apart.

Caution:

Take care not to pinch your skin while sliding the shell.



- 2 Select the Shift Shell that includes the pre-installed Adjustable Retention Unit. Slide the trigger guard* onto this half shell using the two interlocking rails.

*When using the OWB Slide Holster, use the belt slide adapter with the pre-assembled trigger guard.



- 3 Secure the trigger guard with a twist lock on the bottom of the trigger guard area. To complete your holster, turn to the page of your desired carry position:

IWB Holster - pg. 6

Appendix - pg. 9

OWB Slide - pg. 12



Full Shell Configuration

OWB Paddle + Holster Mount

- 1** If you would like to use a thumb release with your paddle holster, begin by sliding the shells apart. If you do not want to use a Thumb Release, please proceed to Step 3.

Caution:

Take care not to pinch your skin while sliding the shell.



- 2** Insert one narrow hex nut into your thumb release, then place your thumb release into the recess of the trigger guard. Attach the thumb release to the holster with a 1/2" flat head screw.



- 3** Slide the shells together using the interlocking rails.

Ensure the interlocking rails line up while pushing the shells together. If the center rail is aligned, the remaining rails will slide into place.

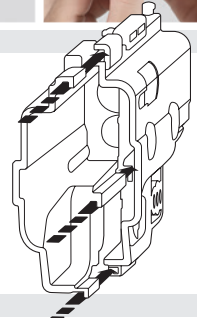

- 4** Secure the shells by adding a twist lock to the top and bottom of the Shift Shell. To complete your holster, turn to the page of your desired carry position:

OWB Paddle - pg. 15
Holster Mount - pg. 18



Customize Your ShapeShift's Retention

Your Core Carry Pack includes two optional retention devices:

Thumb Release - Provides active retention to your OWB paddle holster.

Adjustable Retention Unit - This passive retention comes pre-attached to the Shift Shell.

Your Adjustable Retention Unit

Your **Adjustable Retention Unit** can be tightened by turning the wheel with a twist lock. Spin clockwise to increase your retention.

Additionally, the Adjustable Retention Unit can be repositioned to the opposite side of the trigger guard for further optimization.

To Detach your Adjustable Retention Unit, untwist the twist locks from the top and bottom of your Shift Shell, then slide the two shells apart. Next, unscrew the 1/2" flat head screw from the Shift Shell using the Allen Key provided.



Retention Tips

- 1 Many factors can affect your holster's retention:**
 - draw angle
 - firearm model
 - carry position
- 2 Be sure to practice drawing your firearm while wearing your holster just as you would in a real-life scenario.**
- 3 Pay attention to the twist of your wrist as you draw your firearm as this will greatly affect the performance of your retention settings.**

Attaching the Thumb Release to Your Shell

- 1** To use a thumb release with your paddle holster, untwist the twist locks from the top and bottom of your Shift Shell, then slide the shells apart.
- 2** Insert one narrow hex nut into your thumb release, then place your thumb release into the recess of the trigger guard. Attach the thumb release to the holster with a 1/2" flat head screw.
- 3** Slide the shells together using the interlocking rails. Secure the shells by adding one twist lock to the top and one to the bottom (clockwise) of the Shift Shell.



IWB HOLSTER

FLEX FORM

The flexible design of the ShapeShift IWB conforms to your waist and requires zero break-in time.

COOLVENT NEOPRENE

This perforated material allows for airflow, keeping you cool and comfortable all day.

STEEL CORE RETENTION

A patented steel core provides enhanced retention to the concealed carrier.

*Modular Comfort.
Advanced Concealment.*



IWB Holster Assembly

This carry position requires the half shell configuration. Make sure the trigger guard is attached to the shell. Please refer to Page 3 for more information.



1 Prepare the holster base.

Remove the connector lock from the IWB holster base.



2 Attach the Shift Shell

Press the half Shift Shell onto the holster connector.



3 Secure the shell.

To secure the shell, slide the connector lock onto the holster connector.



4 Don't forget the twist lock!

Add the final twist lock to the outside of the holster connector and rotate clockwise to lock it in place.



5 Customize your retention!

Customize the retention on your Adjustable Retention Unit by twisting the wheel with a spare twist lock.

Tip: *Carrying inside-the-waistband naturally increases your holster's retention. Be sure to test your retention by wearing your holster before making final adjustments. Refer to "Retention Tips" - pg. 5*



How to Wear Your IWB Holster

Picturing your waist as a clock with your belt buckle at noon, the best position to wear the Alien Gear Inside-the-Waistband (IWB) Holster is the 4:30 position. To keep your handgun hidden, pick a location where it will lie flat against your body. Be sure to wear a sturdy belt.

Ensure your firearm is unloaded and safe prior to the following steps.

- 1 Leave your pants unbuttoned and unzipped. Insert the holster into the front of your pants, just to the right of the zipper. Slide the holster around to your desired location.



- 2 Pull the clip over your belt, and attach the second clip. Button and zip your pants, then buckle your belt. Tug on the holster to ensure the clips are securely fastened.



- 3 Carefully and slowly, insert the pistol and make sure there is no clothing or obstruction in the holster that can catch the trigger. Now, tuck your shirt in or drape the fabric over the holster.



How to Adjust Your IWB Holster

Cant

Cant is the angle your handgun is pointed. This will require you to detach the clips from the holster base. Remove the clips by positioning them 180 degrees downward, then pull straight out.

To increase the cant, raise the front clip, lower the back clip, or do both. To decrease the cant, lower the front clip, raise the back clip, or do both.

Ride Height

Ride Height is how high or low the holster sits on your belt. To raise the ride height, lower both clips. To lower the ride height, raise both clips.



APPENDIX



COOLVENT NEOPRENE

This perforated material allows for airflow, keeping you cool and comfortable all day.

SMALL FOOTPRINT

A minimal design provides more comfort and concealment than ever before. Guaranteed.

CUSTOM RETENTION

Discover the perfect drag to your draw with the Adjustable Retention Unit.



Appendix Carry—Reborn.

Appendix Carry Assembly

This carry position requires the half shell configuration. Make sure the trigger guard is attached to the shell. Please refer to Page 3 for more information.



1 Attach the Shift Shell to the holster base.

Press the half Shift Shell onto the holster connector located on the AIWB-OWB Holster Base.



2 Add the appendix clip.

This kit includes a small and large frame appendix clip. Choose the clip that best fits your specific gun type. Slide the appendix clip up and over the holster connector.



3 And for the final touch...

Add the final twist lock to the outside of the holster connector and rotate clockwise to lock it in place.



4 Customize your retention!

Customize the retention on your Adjustable Retention Unit by twisting the wheel with a spare twist lock.

Tip: *Carrying inside-the-waistband naturally increases your holster's retention. Be sure to test your retention by wearing your holster before making final adjustments. Refer to "Retention Tips" - pg. 5*



How to Wear Your Appendix Holster



Picturing your waist as a clock with your belt buckle at noon, the most popular position to wear the AIWB Holster is the 1:30 position, but you can wear it anywhere along the waistline. Be sure to wear a sturdy belt.

Ensure your firearm is unloaded and safe prior to the following steps.

- 1 Leave your pants unbuttoned and unzipped. Insert the holster into your pants in the front just to the right of the zipper. Slide the holster around to your desired location.



- 2 Pull the single appendix clip over your belt. Button and zip your pants, then buckle your belt. Tug on the holster to ensure the clip is securely fastened.



- 3 Carefully and slowly, insert the pistol and make sure there is no clothing or obstruction in the holster that can catch the trigger. Now, tuck your shirt in or drape the fabric over the holster.





SLIM DESIGN

This is the most concealable OWB holster ever made. Period.

ADJUSTABLE RETENTION

Achieve the perfect drag to your draw.

COOLVENT NEOPRENE

This perforated material allows for airflow, keeping you cool and comfortable all day.

*A Comfortable, Concealable
OWB Holster.*



OWB SLIDE

OWB Slide Holster Assembly

▶ *This carry position requires the half shell configuration, including the belt slide adapter with the pre-assembled trigger guard. Please refer to Page 3 for more information.*



1 Attach the Shift Shell onto the base.

Press the half Shift Shell onto the holster connector located on the AIWB-OWB Holster Base.



2 Secure the Shift Shell.

To secure the shell, slide the belt slide lock over the holster connector.



3 Lock it up!

Add one twist lock to the outside of the holster connector and rotate clockwise to lock it in place.



4 Customize your retention!

Customize the retention on your Adjustable Retention Unit by twisting the wheel with a spare twist lock. Test your retention by wearing your holster before making final adjustments. Refer to "Retention Tips" - pg. 5



How to Wear Your OWB Slide Holster



- 1 To begin, you'll want a sturdy belt. With your belt unbuckled, move the slide attachment along your belt to the position of your preference.



- 2 Finish by threading the belt through your belt loops, pull it snug, then fasten your buckle.



OWB PADDLE



360° ROTATION

Customize your cant (angle) in one fluid motion.

SECURE DESIGN

The durable paddle prevents any unwanted holster movement.

ADAPTABLE

Go from the paddle to a variety of carry positions in seconds.



Where Comfort Meets Security.

OWB Paddle Holster Assembly



▶ *This carry position requires the full shell configuration. Please refer to Page 4 for more information.*

1 Paddle or Belt Slide Attachment?

If you would prefer carrying with the belt slide attachment, begin by unscrewing the paddle attachment. If you prefer the paddle, please skip to Step 3.



2 Connect your belt slide.

Attach the belt slide attachment to the holster mount using four weld nuts and four 3/8" button head screws.



3 Choose your angle.

Attach the rotating adapter to the paddle (or belt slide) by holding down the button located on the holster mount. Press the shell and paddle together until the button comes out and the two pieces are secure.



4 Customize your retention!

Customize the retention on your Adjustable Retention Unit by twisting the wheel with a spare twist lock. Test your retention by wearing your holster before making final adjustments.
Refer to "Retention Tips" - pg. 5



How to Wear Your OWB Paddle Holster

- 1 The paddle attachment can be worn in two ways: Clipped to your belt OR clipped to your waistband. Choose the location that feels most secure to you.



- 2 Once the holster is on, give it a good tug to ensure it's not going anywhere. Be sure to wear a sturdy belt.



How to Adjust Your OWB Paddle Holster

- 1 **Cant** is the angle your handgun is pointed. To adjust your cant, press the button on the side of the holster mount and pull the Shift Shell straight out.



- 2 Once you have determined your preferred angle, hold down the holster mount button while reinserting the rotating adapter. Press down firmly until the button comes out and the two pieces are secure.



HOLSTER MOUNT

MULTI-SURFACE COMPATIBLE

Attach your Holster Mount to a variety of surfaces, including wood, drywall, sheet metal and plastic.

SECURE DESIGN

The durable, stable holster prevents any unwanted holster movement.

ADAPTABLE

Go from the OWB paddle to a variety of surfaces in seconds using the quick release button.

*From Your Waist
to Your World.*



Holster Mount Installation

The Holster Mount requires the full shell configuration. Please refer to Page 4 for more information.



1 Find a perfect place for your holster.

To install your holster mount, begin by finding a structurally sound surface.



2 Prepare your mounting surface.

Using the Holster Mount as a template, mark four holes with a pencil. Drill four pilot holes with the 1/8" drill bit into a wood or plastic surface.

For **drywall installation**, we recommend using a 1/2" drill bit (not included) to make four pilot holes large enough to accommodate four drywall anchors.

For **sheet metal installation**, there is no need to make pilot holes; instead use the self-driving metal screws.



3 Attach your Holster Mount to the surface.

Using the appropriate screws (wood for wood, plastic for plastic, etc.) attach the Holster Mount to the surface.

For drywall, thread each drywall screw first through the Holster Mount and then the drywall anchor prior to installation. Thread the screws just enough to get it started.

Next, compress the drywall anchors as you insert them through the pilot holes. Once inserted, ensure the anchors fully expand inside the wall. Secure the Holster Mount by tightening the drywall screws.



4 Connect your holster.

Attach your holster to the surface by holding down the button located on the Holster Mount. You can attach your holster at virtually any angle.



5 Test it out!

Ensure that your holster is secure.



▶ *To ensure the provided screws are an appropriate length, measure the thickness of the mounting surface prior to installation.*

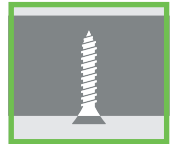

Warning: Tedder Industries, LLC d/b/a Alien Gear Holsters is not liable for any property damage that may be caused during the ShapeShift Holster Mount installation process or anytime thereafter. As a safety precaution, be sure to attach your ShapeShift Holster Mount to a structurally sound surface prior to use. **DO NOT** install the ShapeShift Holster Mount onto or over any vehicle airbag as it may result in personal injury. Neither the ShapeShift Modular Holster nor the ShapeShift Holster Mount are intended to be used as a firearm safety device. As always, we recommend that appropriate precautions be used with firearms, and that firearms be stored in a safe and child-free area.